

# Recent Developments in Control Schemes of BLDC Motors

Vinatha U, Sl. Grade Lecturer, Swetha Pola, M.Tech. (PES) Student, Dr.K.P.Vittal, MIEEE, Asst.Prof.  
 Dept. Electrical & Electronics Engineering, National Institute of Technology,  
 Karnataka, Mangalore – 575025  
 vittal\_nitk@yahoo.com

**Abstract-** This paper presents a technical review of published literature addressing control schemes for BLDC motors. The control methods reviewed include sensor less control, PWM techniques used, various methods for rotor position detection and initial rotor position detection methods.

## I. INTRODUCTION

Brushless DC motors are widely used as small High Power (HP) control motor and increasingly user for larger HP applications such as hybrid vehicles. In DC commutator motor, current polarity is altered by commutator and brushes. In the brushless DC motor polarity reversal is performed by power transistors switching in synchronization with the rotor position. To accomplish this, BLDC motor is inverter fed. Inverter is designed in such a way that, its out put frequency is function of instantaneous rotor speed and its phase control will correspond to actual rotor position.

Typically a BLDC motor is driven by a 3 phase inverter with six step commutation. In the conventional approach, 120° PWM method is used where the conducting interval of each phase is 120° electrical angle as shown in Fig 1. In order to produce maximum torque, inverter should be commutated every 60°, so that the current is in phase with the back emf. Commutation timing is determined by the rotor position and the sequence of commutation is retained in the proper order so that the inverter performs the function of brush and commutator in a conventional DC motor to generate a rotational stator flux. At one time instant, only 2 out of the 3 phases are conducting current, and one winding is floating.

The conventional 120° PWM method has merit of low switching losses in the inverter side but posse's high harmonic content. This results in increase in loss on the motor side [1, 2, 3, 4, and 5]. Conventionally, three Hall sensors were used as position sensors to perform current commutations every 60 electrical degrees. Resolver or absolute encoders were used as rotor position sensors for servo drive applications. All sensors increase the cost, size of motor and reduce reliability. For this reason BLDC motor without position or speed sensors is becoming more popular.

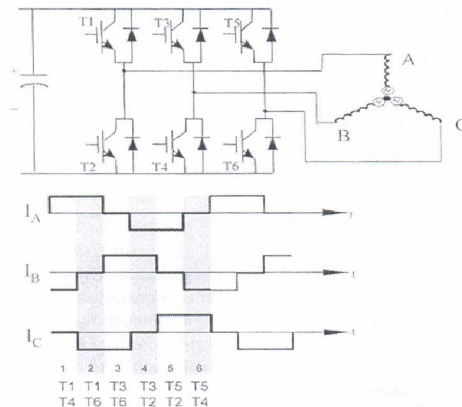

Fig.1. Inverter configuration and current commutation sequence for BLDC motor

## II. REVIEW OF SENSORLESS CONTROL METHODS

In the conventional control methods, rotor position is detected every 60 electrical degrees. Based on principle of operation, these methods are grouped as follows:

1. Using the back EMF of motor [6, 7, 8, 9, 10, 11, 12, 13, 14, 15]
2. Detection of conducting state of freewheeling diodes in the unexcited phase [16]
3. Stator third harmonic components [17]

These methods do not provide rotor position estimation on continual basis. Therefore not applicable where high estimation accuracy of position is required.

### A. Direct back EMF detection for sensorless BLDC drives

Sensing back EMF of unused phase is the most cost efficient method to obtain the commutation sequence in star wound motors. Here the emf of the floating phase is sensed and the zero crossing of this emf detected by comparing with neutral point voltage. In most cases (Fig 2) it becomes necessary to build virtual neutral point [6, 7]. This scheme even though simple suffers from high common mode voltage and high frequency noise due to the PWM drive. So, it requires low pass filters and voltage dividers. Filter will introduce commutation delay at high speeds and attenuation causes

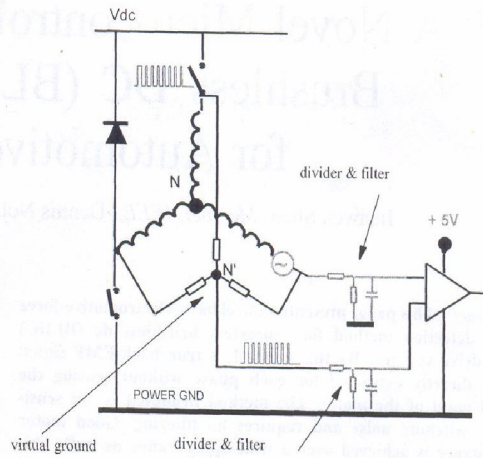

Fig 2 .Back EMF sensing based on virtual neutral point

reduction in signal sensitivity at low speeds. Consequently speed range is narrowed. In order to reduce switching noise back EMF integration and third harmonic integration methods are used [9] .Also Various PWM techniques are developed.

1) PWM technique which eliminates virtual neutral point

Jianwen Shao et.al [6] and T.Endo et...al. [8] have presented a back EMF sensing method which does not require a virtual neutral point and large amount of filtering. Here the zero crossing of emf of floating phase is obtained by properly selecting the PWM and sensing strategy. In the scheme proposed by Jianwen Shao et.al [6] PWM signal is applied on high side switches only, low side switches are only switched to provide commutation as in Fig 3. At any instant one phase is driven with PWM high side switch and another phase is driven with the low side switch. Remaining phase is open. Back emf of open phase is detected during PWM off time.

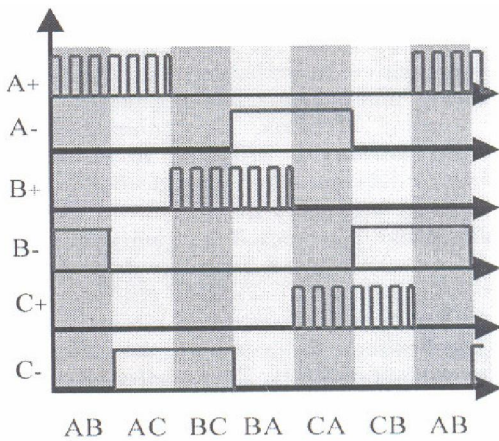

Fig.3. PWM applied to high side switches only

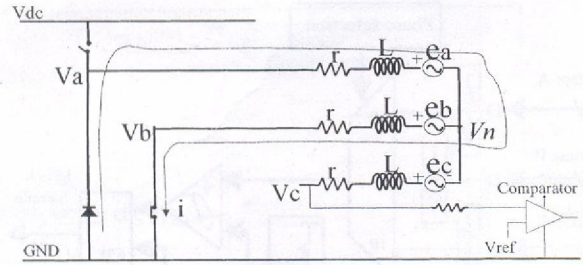

Fig 4 .Winding terminal voltage during PWM off time

Fig 4 shows a particular stage where phase A and B are conducting and phase C floating. Upper switch A is pulse width modulated and lower switch of phase B is on during the entire step, switched only at commutation. When upper switch of phase A is turned off current freewheels through the diode. Neglecting forward voltage drop across the diode for the phase A and voltage drop across the device for phase B we can get  $V_c = e_c + V_n = e_c(3/2)$ . During PWM off time terminal voltage of the floating phase  $V_c$  is proportional to back EMF  $e_c$  with some gain without any superimposed switching noise. Also terminal voltage is referred to ground instead of neutral point.

As a result there are no common mode voltage issues. since true back emf is extracted from the terminal voltage zero crossing of the back EMF can be detected very precisely. Resulting signal is not attenuated or filtered and there by provides a signal with good signal/noise ratio. This scheme provides a much wider speed range.

2) PWM technique at low speed applications

For low voltage applications the voltage drop across the body diode of the MOSFET's will affect the performance. When the motor speed goes low, zero crossing is not evenly distributed. If the speed goes further low, the back emf amplitude becomes too low to detect. Two methods to correct the offset voltage of back EMF signal are presented by Jianwen Shao et al. [10]. First method is to use complementary PWM as shown in Fig 5. This also reduces the conduction loss. Another method to eliminate the effect of diode voltage drop is to add a constant voltage to compensate the effect of diode and threshold voltage for zero crossing detection. Preconditioning circuits for low speed applications is also presented in [10], which not only compensates the offset voltage caused by diodes but also amplifies the signal of back EMF near zero crossing.

3) Improved Direct back EMF detection scheme

Jianwen Shao et al. [11] have proposed an improved direct back EMF detection for sensorless control of BLDC motor.

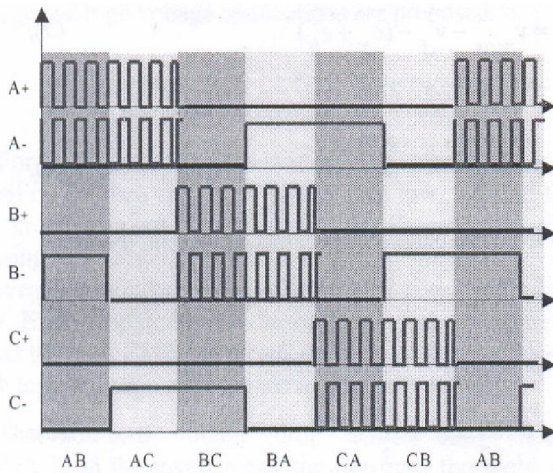

Fig.5. Complementary PWM algorithm

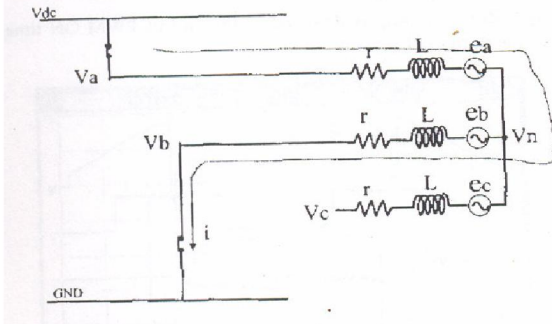

Fig 6 .Winding terminal voltage during PWM on time

This scheme eliminates the limitation of back EMF detection during PWM off time. That is, it cannot go up to 100% duty cycle since minimum off time is needed to have a time window to detect back emf. Here back EMF is detected during PWM on time for some applications where 100% duty ratio is necessary. At lower speed, back EMF detection is done during off time. Fig 6 shows the winding terminal voltage during PWM on time when phase A and B are conducting current and phase C is floating. Under this condition terminal voltage of open phase C is  $V_c = e_c (3/2) + V_{dc}/2$ . Comparing  $V_c$  with  $V_{dc}/2$  gives zero crossing of back emf  $e_c$ . Thus duty cycle limitation can be overcome by synchronously detecting the back EMF during the PWM on time.

#### 4) PWM technique for small power applications

A novel PWM technique for small power BLDC motor drives which reduces the conduction losses and in turn reduces heat dissipation presented in [12,13]. For small power applications of BLDC drives power consumption reduction is the main objective because of the use of battery and limited space for heat dissipation. In the PWM technique presented by Yen-Shin Lai et al. [12] the high side power device is chopped in 1/6 fundamental period, duty ratio is derived from the speed reference or error of speed. For the next 1/6 fundamental period, it is clamped to positive dc link for both intervals of high side device, the associated low side device is off as shown in Fig 7. Similar control signals are given to low side devices with 180° shift.

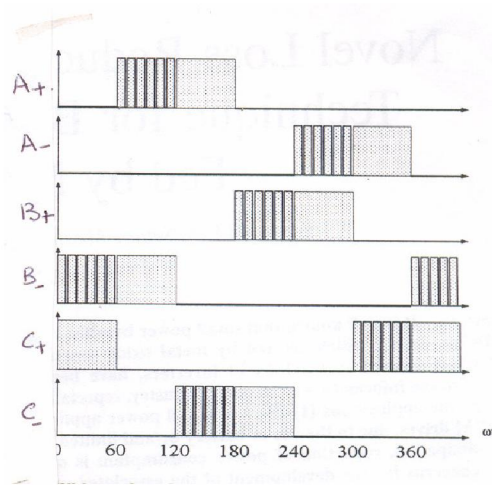

Fig 7 PWM scheme which reduces power loss

However as the low side device is on , output terminal is connected to the negative dc link. For other two phases the control signals are applied with 120° shift.

#### 5) Improved PWM technique for small power applications

The significant heat loss that is produced due to the current flowing through the anti parallel diode during the period when the switch is with chopper control(Fig 7) is reduced in another PWM technique given in [13]. In this PWM technique high side switch is chopped in 1/6 fundamental frequency and clamped to DC link for in the next 1/6 fundamental frequency as shown in Fig 8 .

During the period when high side device is with chopper control the associated low side switch is triggered by inverse signal of chopper control. The on state of low side power device indicates that the output terminal is connected to negative dc link rather than the positive. The low side power switch is also controlled in a similar manner. When it is with chopper control, the associated high side switch is triggered by inverse signal of chopper control signal. For the other two phases control signals are applied with 120° phase shift. With this technique, voltage drop caused by the turn on resistance of power device and the load current, is significantly reduced as compared to forward voltage drop of diode. Hence results in reduction in power consumption and method is promising for small power applications.

#### B. DSP based Sensorless control for high speed applications

Based on the method of executing the PWM control, schemes are classified as uni polar and bipolar switching schemes. In uni polar switching method PWM is applied to one of the two active switches in on state while the other switch remains ON state [6, 10]. In bipolar switching scheme both the active switches are applied with PWM at the same time [7, 8, 12, 13, and 14]. Unipolar switching scheme has the advantage of reduced switching loss. Unipolar switching is further classified into on going phase PWM, off going phase PWM, upper switch PWM, lower switch PWM schemes.

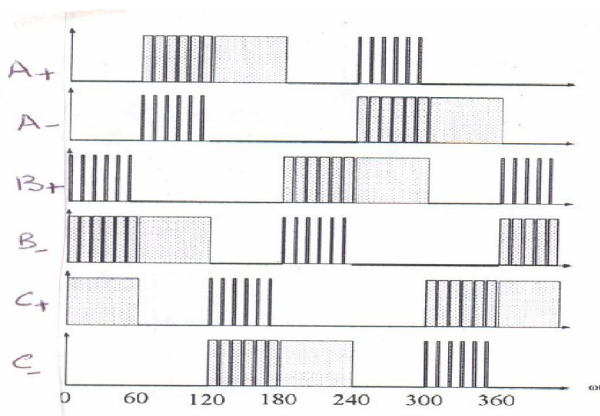

Fig 8 PWM scheme promising for low power applications

In the on going switch PWM scheme each switch executes the PWM during the first 60 degrees of active interval and held on during the second 60 degrees of interval [13]. In the off going PWM each active switch is held on during the first 60 degrees of active interval and applied with PWM in the next 60 degrees [16]. In the upper switch PWM scheme, PWM is given to upper one of the two active switches and in the lower switch PWM vice versa [6, 10].

Depending on the PWM method used, the control scheme may cause a commutation delay in high speed applications, since the PWM switching and the inverter commutation cannot be done independently. If the commutating instant is synchronized with the end of the PWM switching period, ideal commutation occurs with out any delay. But, since the commutating instant depends on the rotor position, it does not generally coincide with the end of PWM period. In such cases undesirable commutation delay is produced, if the commutation is performed with the end of the present PWM period as shown in Fig 9. One way of avoiding this delay is to terminate the present PWM period and synchronize a new PWM period with the commutation instant. But this may cause an irregular switching frequency in upper and lower switch PWM schemes. In on going and off going phase PWM schemes this method can be used for high speed sensorless control. However, only few pulses of PWM can be used for speed control during a 60 degree interval in high speed range. Commutation delay can be reduced by increasing the PWM switching frequency. But there is a practical limitation on the switching frequency due to the increased switching losses, switching frequency of commercially available power devices is less than 20 kHz. These problems are over come by controlling the voltage and frequency independently by DC link voltage control scheme.

A DSP based high speed sensorless control scheme using a DC link voltage control is presented by Kyeong-Hwa Kim et al [14]. Here the inverter is supplied with a square wave of 120 degree conducting interval whose frequency is controlled and speed control is obtained by regulating the DC link voltage of the inverter shown in Fig 10 fed from a step down chopper. Rotor position information is detected using the back EMF.

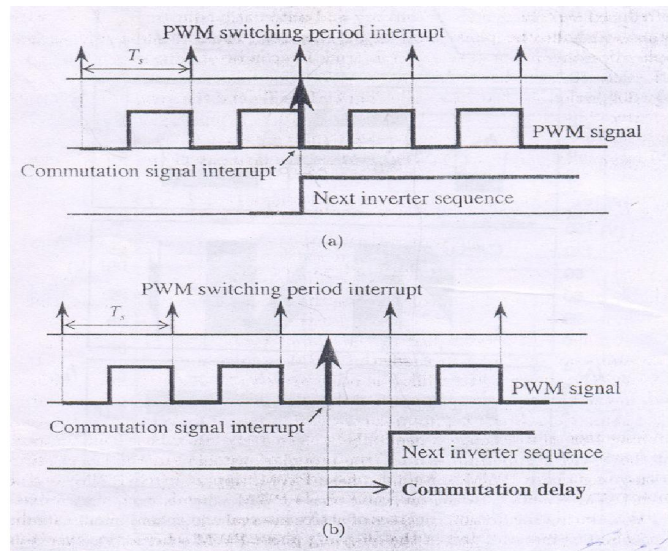

Fig.9. Relation between the PWM switching period and commutating instant (a) Ideal commutation.(b)Case of commutation delay

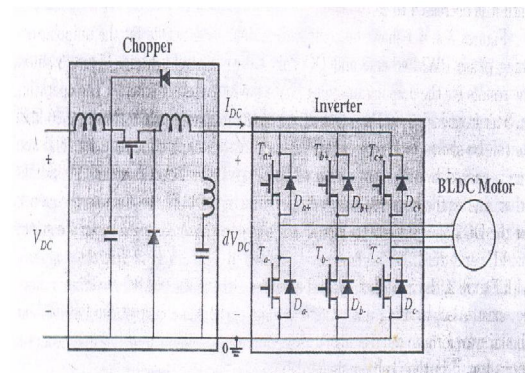

Fig 10.Circuit configuration for a DC link voltage control scheme

Commutation signals and actual speed are obtained using the sensed back EMF by means of integration and comparison circuits. Using a digital PI controller and the calculated value of speed, duty ratio of chopper is controlled .With this two phase PWM method can be used even in high speed region without any commutation delay.

### C. Microprocessor based sensorless controllers

Microprocessor are playing major role in building the controllers. In [15], a control scheme for sensorless control of BLDC motor is presented which requires back EMF sensing from only one of the EMF of 3 phase motor.

The signal sensed is fed into an integrator as shown in Fig 11 for filtering and introducing necessary delay. Then the signal is fed to zero crossing detector which produces two commutation instants per fundamental cycle. In practice a low pass filter is used to extract the phase information from the back EMF as in Fig12 since an ideal integrator cannot be used. In that case phase delay introduced by the filter varies with the motor speed and has to be corrected in order to produce correct commutation timing. The output of zero crossing detector is

#### IV. INDIRECT BACK EMF DETECTION BY DETECTING THE CONDUCTING STATE OF FREE WHEELING DIODES

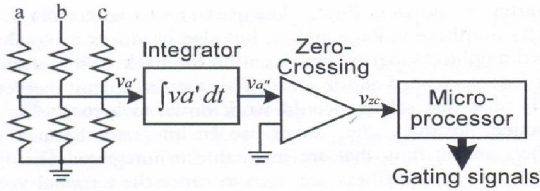

Fig 11 Rotor position sensing circuit using only one motor terminal voltage

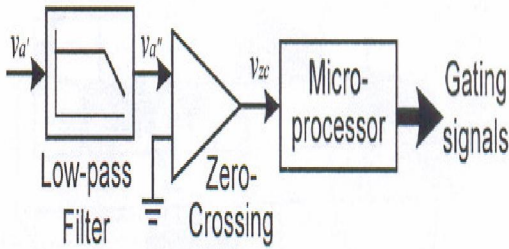

Fig12. Rotor position sensing circuit using low pass filter

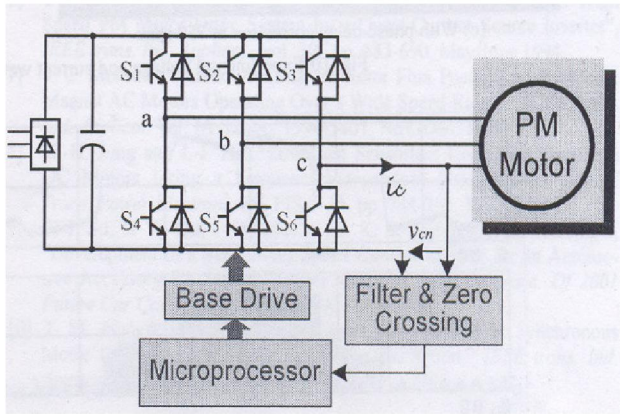

Fig13. Position and sensorless control fed to a microprocessor. Microprocessor measures the time elapsed between two instants and generates the other two commutation instants by interpolation. This leads to a significant reduction in components of position sensing circuit and thereby considerable cost saving due to coupling of sensing circuit to a single chip microprocessor or DSP for speed control as shown in Fig 13.

#### III. INDIRECT BACK EMF DETECTION USING STATOR THIRD HARMONIC COMPONENTS

In [17] sensorless control of brushless machines by detecting third harmonic back EMF has been presented which is applicable for the operation in flux weakening mode. Methods based on zero crossing of back EMF are simple but applicable under normal operating conditions. It cannot be applied if commutation advance or the current decay in freewheeling diode is greater than 30 electrical degrees. In such case third harmonic components of back EMF are used.

In [16], position information detection method based on the conducting state of diodes in the open phase has been presented. Current flowing in the open phase results due to back emf produced in the motor windings. This current becomes zero in the middle of commutating interval. Position information is obtained every 60 degrees by detecting the conducting interval of free wheeling diodes. Detected position signal leads the next commutation by 30 degrees hence the commutation signal to the inverter is given through a phase shifter. This approach makes it possible to detect the rotor position over a wide speed range. This is an indirect detection of back EMF through free wheeling diodes which requires additional power supplies for the comparator circuitry for each freewheeling diode.

In [18, 19, and 20], a method for continual estimating the rotor position and speed is presented. This method is based on application of Extended Kalman Filter. Motor state variables are estimated by using measurements of stator line voltages and currents and applying EKF. During this process, voltage and current measuring signals are not filtered. Rotor position and speed can be estimated with sufficient accuracy in both steady state and dynamic operations.

Accurate position and speed feed back information for closed loop control based on vector control technique is presented in [20]. Here Kalman filter is used for mechanical state estimation of the motor.

#### V. INITIAL ROTOR POSITION DETECTION TECHNIQUES OF BLDC MOTORS

In order to avoid wrong direction of rotation at start which is essential for particular applications like electric vehicle, initial position of the permanent magnet should be identified clearly.

Open loop starting is achieved by providing a rotating stator field that is gradually increasing in magnitude and/or frequency. Rotor gets attracted to the stator field and begins to rotate. When the stator field becomes just strong enough rotor can move in any direction. Disadvantage of the method is that initial rotor movement cannot be predicted. Also if the stator field is too large then the rotor will be subjected to oscillations.[21].

In [18, 19] rotor position is estimated using Kalman filter from measured stator line voltages and currents.

In [21,22, and 23], an initial position detection technique is presented which does not require current and position sensors.

Basic principle to initial position detection of 3 phase BLDC motor is based on the relationship between rotor position and inductance of stator windings. Inductance of stator winding for non saturated case (when the field of stator and rotor are with 180° phase shift) is greater than in the saturated case. The value of stator inductance which depends on rotor positions is used for rotor position detection.

Many methods are proposed for detection of rotor position by indirectly detecting stator inductance [21, 22]. These

include detecting peak value of stator currents, and may be classified as,

- i. Current after excitation: Where stator windings are excited for a short period less than  $\tau$  of stator circuit. Peak value for saturated case greater than for unsaturated case.
- ii. Detecting current magnitude: Magnitude of stator currents are sensed for a given time after excitation, with different excitation. Current for saturated case is greater than linear case.
- iii. Detecting rise time of stator winding after excitation: here step voltage is applied to stator and rise time is detected which is similar for unsaturated case than linear case. For above three approaches initial position is identified using 6 different excitation configurations by comparing peak, magnitude or response speed of currents associated with the exciting signal. These approaches do not require current sensors or position sensors.
- iv. Detecting falling time of stator winding after removing excitation signal: Here falling time of current is detected which is greater for saturation case than linear case.

In [22, 23], initial position is identified by measuring the period of falling time of stator windings instead of using falling times. Period of falling time for linear case is greater than saturated case because large inductance stores more electrical energy and increases the falling time of discharge after the excitation signal is removed. This result in a larger freewheeling period for the associated winding during the discharge process therefore terminal voltages across the windings are measured instead of current for identifying the rotor initial position.

## VI. CONCLUSION

A review of sensorless control of BLDC motors is presented and their important features are discussed. Methods of detecting initial rotor position are also presented in an effort to provide reference for utilizing these methods.

## REFERENCES

- [1] Krishnan R ,Motor drives modeling analysis and control, *prentice hall of India* 2002.
- [2] Krishnan, R. Lee, S, "PM Brushless dc Motor Drive With A New Power-Converter Topology", *IEEE Transactions on Industry Applications*, Vol. 33 , Issue: 4 pages 973 - 982, July-Aug. 1997 .
- [3] Byoung-Kuk Lee, Tae-Hyung Kim, and Mehrdad Ehsani, " On the Feasibility of Four-Switch Three-Phase BLDC Motor Drives for Low Cost Commercial Applications: Topology and Control", *IEEE Transactions On Power Electronics*, Vol. 18, No. 1, Jan 2003.
- [4] Bimbira.P.S, "Power Electronics"
- [5] Rahul Khopkar,S.M.Madan,Masoud HaJiaghajani and Hamid A. Toliyat, "A Low-Cost BLDC Motor Drive using Buck-Boost converter for Residential and Commercial Applications",*IEEE* 2003.
- [6] Jianwen Shao, Member, IEEE, Dennis Nolan, Maxime Teissier, and David Swanson, "A Novel Microcontroller-Based Sensorless Brushless DC (BLDC) Motor Drive for Automotive Fuel Pumps," *IEEE Trans.Ind.Applic.*, vol.39, NO.6, NOV/DEC 2003.
- [7] T .Endo and F.Tajima, "Microcomputer controlled brushless motor without a shaft mounted position sensor", in *Proc IPEC-Tokyo*, 1983.

- [8] Jianwen Shao, Member,IEEE, Dennis Nolan and Thomas Hopkins, "A novel Direct Back EMF Detection for Sensorless Brushless DC(BLDC) Motor Drives,"in *Proc. IEEE APEC*,2002.
- [9] Becerra R C . , Jahns, T.M. , and Ehsani,M . , "Four -quadrant sensorless brushless ECM drive", *IEEE Applied Power Electronics Conference and Exposition*, 1991
- [10] Jianwen Shao, Member, IEEE, Dennis Nolan and Thomas Hopkins, "Improved Direct Back EMF Detection for Sensorless Brushless DC (BLDC) Motor Drives," *IEEE* 2003
- [11] Jianwen Shao, Member, *IEEE*, Dennis Nolan, "Further Improvement of Direct Back EMF Detection for Sensorless Brushless DC(BLDC) Motor Drives," *IEEE* 2005.
- [12] Yen-Shin Lai, Fu-San Shyu, Yung- Hsin Chang, "Novel Pulse-Width Modulation Technique With Loss Reduction For Small Power Brushless dc Motor Drives", *Industry Applications Conference, 2002. Conference Record of the 37th IAS Annual Meeting*, Vol. 3, 13-18 Pages: 2057 - 2064 Oct. 2002.
- [13] Yen-Shin Lai, Fu-San Shyu, Yung- Hsin Chang, "Novel loss reduction Pulse-Width Modulation Technique For Brushless dc Motor Drives Fed by Mosfet Inverter", *IEEE Transactions On Power Electronics*, Vol. 19, No. 6, Nov. 2004.
- [14] Kyeong-Hwa Kim and Myung-Joong Youn, "DSP-Based High-Speed Sensorless Control for a Brushless DC Motor Using a DC Link Voltage Control",*Electric Power Component And Systems*,30:889-906,2002.
- [15] Gui-Jia Su and John W.Keever, "Low Cost Sensorless Control Of Brushless DC Motors with Improved Speed Range", *IEEE* 2002.
- [16] Satoshi Ogasawara and Hirofumi Akagi, "An Approach to Position Sensorless Drive for Brushless DC Motors,"*IEEE Trans On Industry Applications*, Vol. 27, No. 5. SEP/OCT 1991.
- [17] J.X.Shen,Z.Q.Zhu and David Howe, "Sensorless Flux-Weakening Control Of Permanent-Magnet Brushless Machines Using Third Harmonic Back EMF", *IEEE Transactions On Industrial Electronics*, Vol. 40, No. 6, Nov/Dec 2004.
- [18] R.Dhaouadi, N Mohan, and L.Klepsch, "Design and Implementation of the Extended Kalman Filter for the Speed and Rotor Position Estimation of Brushless DC Motor", *IEEE Transactions on Power Electronics*, Vol. 48, No. 6, July 1991.
- [19] Bozo Terzic and Martin Jadric, "Design and Implementation of the Extended Kalman Filter for the Speed and Rotor Position Estimation of Brushless DC Motor", *IEEE Transactions On Industrial Electronics*, Vol. 48, No. 6, December 2001.
- [20] Mihai Cemat,Vasile Comnac, Radu-Marian Cemat and Maria Cotorogea , "Sensorless Control of Interior Permanent Magnet Synchronous Machine Using a Kalman Filter",*IEEE* 2000.
- [21] James P.Johnson,M.Ehsani and Yilchan Guzelgunler, "Review Of Sensorless Methods for Brushless DC",*IEEE* 1999
- [22] Yen-Shin Lai, Fu-San Shyu, and Shian Shau Tseng, "New Initial Position Detection technique for Three-Phase Brushless DC Motor Without Position and Current Sensors", *IEEE Transactions On Industry Applications*, Vol. 39, No. 2, March/April 2003.
- [23] Yen-Shin Lai, Fu-San Shyu, and Shian Shau Tseng, "A Novel starting method of sensorless salient pole brushless motor",*Conf Record IEEE*, Vol. 1, No. 2, October 1994