

PERFORMANCE EVALUATION OF POWER TRANSMISSION LINE TOWER MADE OF POLYMER MATRIX COMPOSITE

Thesis

Submitted in partial fulfillment of the requirement for the degree of

DOCTOR OF PHILOSOPHY

By

SELVARAJ M



**DEPARTMENT OF MECHANICAL ENGINEERING
NATIONAL INSTITUTE OF TECHNOLOGY KARNATAKA
SURATHKAL MANGALORE -575025**

APRIL 2013

DECLARATION

I hereby declare that the Research Thesis entitled “**Performance evaluation of power transmission line tower made of polymer matrix composite**” which is being submitted to the **National Institute of Technology Karnataka, Surathkal** in partial fulfillment of the requirements for the award of the degree of **Doctor of Philosophy** in **Department of Mechanical Engineering** *is a bonafide report of the research work carried out by me.* The material contained in this Research Thesis has not been submitted to any University or Institution for the award of any degree.

Register Number: 070529ME07P03

Name of the Research Scholar: Selvaraj M

Signature of the Research Scholar:

Department of Mechanical Engineering

Place : NITK-Surathkal

Date : 15-04-2013

CERTIFICATE

This is to certify that the Research Thesis entitled “**Performance evaluation of power transmission line tower made of polymer matrix composite**” submitted by **Mr. Selvaraj M. (Register Number: 070529ME07P03)** as the record of the research work carried out by him, is accepted as the Research Thesis submission in partial fulfillment of the requirements for the award of the degree of **Doctor of Philosophy.**

Dr. S. M. Kulkarni
Research Guide

Dr. R.Ramesh Babu
Research Guide,
CPRI, Bangalore

Chairman-DRPC

Department of Mechanical Engineering
National Institute of Technology Karnataka, Surathkal

ACKNOWLEDGEMENT

I am very grateful to my supervisor **Dr. S. M. Kulkarni**, Professor, Department of Mechanical Engineering, National Institute of Technology Karnataka Surathkal for his invaluable constructive guidance and encouraging association throughout the period of my research work. He has the unique ability to motivate students through constant optimism, patience and encouragement. It has been an honor and a pleasure to work and I will always be grateful to him for giving me the opportunity to learn and grow under his guidance.

My sincere thanks to my co-supervisor **Dr. R. Ramesh Babu**, Additional Director, Central Power Research Institute (CPRI), Bangalore for his valuable suggestions and guidance throughout the period of my research work. He always used to instil great confidence in me. I thank him for generously for sharing his knowledge and time. I have had the privilege of working under him and benefitted by him to accomplish this incredible in this short period.

I wish to thank **Dr. Prasad Krishna**, Professor and Head, Department of Mechanical Engineering, **Dr. G.C. Mohan kumar**, Professor and former Head, **Dr. Vijay Desai**, **Dr.K.V.Gangadharan**, **Dr. Katta Venkataramana**, **Dr. Navin karanth** for their encouragement and moral support during my research work. I express my thanks to all the faculty members of Department of Mechanical Engineering, NITK Surathkal for their unstinted support all through this research work. I take this opportunity to thank **Dr. M.C.Narasimhan** and **Dr. Jagannath Nayak** for their continuous and timely suggestions as members of Research Program Assessment Committee.

I wish to express my gratitude to **Sri.N.Murugesan**, Director General, Central Power Research Institute (CPRI) Bangalore for inspiration and motivational words throughout this research work and without his constant support and encouragement this work might not come into this shape.

I would like to show my gratitude to all my previous heads of the division **Sri.P.Muniyappa**, Additional Director (Retd), **Sri. P.Krishnamurthy**, Additional Director (Retd), **Sri. B.N. Dinesh kumar**, Joint Director and current head **Sri. D.Revanna**, Joint Director for extending the co-operation to do research work along with regular work. I am indebted to all my colleagues of Mechanical Engineering Division at CPRI **Sri.M.D.Ananthababu**, Joint Director, **Sri. B.M.Varadharaju**, Engg. Officer, **Sri. Sharan Gouda**, Senior Research Fellow, **Sri.U.Easudass**, **Sri.Narashimmiah**, **Sri.M.Soloman**, **Sri. Shivakumar M/s. Design Centre**, **Sri.Saleem Pasha** and M.Tech students from NITK Surathkal **Ravi kumar**, **Yogendra and Umesh Babu** who assisted me in the research work.

I would like to thank **Dr. R. S. Shivakumara Aradhya**, Additional Director, **Dr. N.Vasudev**, **Sri. Gajendra**, **Sri. Badrinarayanan** (Retd) and technicians of High Voltage Laboratory of CPRI, Bangalore for their help in conducting electrical test. I extend my special thanks to **Sri. V. Asaithambi**, **Dr. C. Viswanatha** of Insulation lab, **Dr. P. Sampath kumar**, **Sri. R. K. Kumar** of Materials Technology Division and **Sri. Panner Selvam** of EVRC from CPRI Bangalore for their help in carrying out material tests.

I am grateful to all my friends and relatives and colleagues at CPRI, Bangalore for their informal support and encouragement which has been indispensable.

Finally, this thesis would never have been written without the constant, continuing and unwavering support of my wife **Mrs. M.Vasugi**, my daughters **S.Keerthana** and **S.Rithanya**.

Selvaraj M

ABSTRACT

The design of power transmission lines is done to meet multiple constraints – electrical, mechanical and environmental. Thus designers are generous in deciding the margin to meet the above. But presently, with limited space for transmission lines, need for reduction in transmission line space in both horizontal i.e., Right of Way (ROW) and vertical i.e., height of tower has arisen. Several attempts are made to achieve this reduction at the same time reducing the cost. Use of composites for tower and its components is an attempt directed to decrease the space and the cost. Polymer composite materials have emerged as promising engineering materials due to their light weight and non – corrosiveness. The available literature provide few details of polymer matrix composites as alternative materials for tower but a systematic and holistic study on developing and testing of a tower with composites is yet to see the light.





Thus, the present work is focused on development of a tower with composite members and test it for meeting mechanical and electrical performances and also achieve reduction in ROW and cost. The work considers two approaches, first is FE analysis and the next is physical building of tower components at different levels and the full tower to test for the performance. As a preliminary step, properties of glass-epoxy material processed with pultrusion are determined to assess its suitability in tower applications. Subsequently, various tower members are fabricated with pultrusion process the details of which are provided in Table.1

The tower considered for present work is a 66 kV vertical double circuit lattice type in a line of 200m span operating at a wind speed of 47 m/s. Initially tower and its components are designed as suggested in standard IS: 802 providing all mandatory clearances from the point of electrical insulation.

Cross arm which is one of the major components in tower, is modelled in FEM using dimensions determined earlier. The design of cross arm is verified with FE analysis. Subsequently, FE analysis of a portion of the tower body, tower sub assembly, followed by analysis with cross arm mounted is taken up. FE analysis of a full length tower made of composite member is envisaged as an ultimate part of the study.

Analysis indicated that stress levels in members far below the permissible ones of a material. Thus design of tower and its components is verified.

Table 1. Details of GE pultruded cross arm and tower members

Sl. No	Member	Dimensions of member cross section	Reinforcement	Matrix
1	Solid rectangle section	 20 mm x 70 mm	E- Glass continuous fibres (70 - 75 %)	Epoxy (20-25%) Lapox L-12 Hardener K-6
2	Solid angle section	 50x50x6mm 76.2 x 76.2x6.35	- do-	- do-
3	Solid circular section	 Ø30 mm, Ø33 mm	- do-	- do-
4	Hollow sections	 101.6x101.6x9.525 101.6x101.6x6.35	- do-	- do-

In order to reinforce the feasibility of tower with composite material, physical construction and testing of its components and in the end full tower is taken up. All tests are carried out at station in Central Power Research Institute (CPRI), Bangalore. Initially cross arm is constructed and loads as suggested in standard IS: 802 are applied on the cross arm. The deflection measured at the tip of cross arm is only about 44 mm also strains in members of the cross arm are found to be not very excessive. Prototype testing is extended to a tower sub assembly without cross arm and with cross arm mounted successfully. Later a full length tower with all cross arms mounted in place is constructed and tested. The tower with composite member performed satisfactorily without any visible damage at 100 % full load suggested in standard. The maximum deflection of tower is found to be only 1.4 % of tower height and is within permissible limit of 5 %. The tower with composite member successfully withstood even 300 % full load without any visible signs of failure suggesting a Factor of safety 3.0.

Tests for electrical performance of cross arm and tower with composite members are carried out. Table.2 provides the results of electrical test wherein it can be observed that the test parameters determined are higher than the suggested minimum values. Thus the cross arm and tower satisfactorily meet the electrical requirements.

Table 2. Results of electrical testing

Electrical Performance test	Suggested minimum values in IS:2165	Experimentally determined values	
		Cross arm with tower sub-assembly	Full tower
Power frequency (kV)	140	150	143
Impulse voltage (kV)	325	328	328

From the study it could be inferred that the tower with composite members satisfied both mechanical and electrical requirements. Since the tower is without insulator strings and the associated problems of their swing, the ROW for the line is less and a saving of about 17 % is achieved in ROW. The height of the proposed tower is only 15 m as against 18 m for metallic tower suggested by Indian standard IS: 5613. Thus a saving of about 18 % is achieved. Consequently on account of this lesser height and lower weight of composite members, the saving in total weight of the tower against a metallic tower is about 33 %. Thus with savings and benefits mentioned above, the proposed tower could be most suitable for earthquake prone zones and for Emergency Restoration Systems (ERS).

Keywords : Right of Way (ROW), transmission line tower, cross arm, composites, pultrusion.

CONTENTS

Declaration	
Certificate	
Acknowledgement	
Abstract	
Contents	i
List of Figures	v
List of Tables	xiii
Nomenclature	xv
Chapter 1 INTRODUCTION	
1.0 Overview of electrical transmission	1
1.1 Features of transmission lines	3
1.2 Types and features of towers	4
1.2.1 Components of a typical tower	9
1.2.2 Tower geometry	10
1.3 Tower design	15
1.3.1 Loads on transmission line towers	15
1.3.1.1 Transverse loads	19
1.3.1.2 Vertical loads	21
1.3.1.3 Longitudinal loads	22
1.4 Right of way (ROW) for a transmission line and the role of tower	23
1.4.1 Need for reduction of row and tower height	25
1.4.2 Tower with composite members	26
1.4.3 Pultrusion process for composite members	28
1.5 Design, analysis and testing of tower	29
1.6 Objective and scope of the present study	30
Chapter 2 MODELING	
2.1 Tower geometry based on electrical clearances and other considerations	32
2.1.1 Overall tower height (H)	33
2.1.2 Length of cross arm with composite members	39

2.1.3	Tower base width and bracing pattern	40
2.2	Determination of loads on the tower	42
2.2.1	Transverse load	42
2.2.2	Vertical loads	44
2.2.3	Longitudinal loads	44
2.3	Design of GE pultruded members for tower	49
2.4	Design of cross arm with composite members	52
2.5	Design of full tower with composite members	53
2.6	Finite element analysis of cross arm with composite members	58
2.7	Finite element analysis of X-braced tower sub assembly	59
2.8	Finite element analysis of X-braced tower sub assembly with cross arm	63
2.9	Structural FE analysis of full scale tower with composite members	66
Chapter 3 PROCESSING AND EXPERIMENTAL TESTING		
3.1	Raw materials and methods	69
3.1.1	Manufacturing of composite members	70
3.2	Characterization of GE pultruded material through standard tests	71
3.2.1	Testing for physical properties	72
3.2.2	Evaluation of mechanical properties	72
3.2.3	Accelerated weathering/ ageing test- Xenon arc method	76
3.2.4	Erosion test on GE pultruded material	77
3.2.5	Testing of tower material for dielectric breakdown	78
3.3	Testing of actual size tower members for mechanical properties	79
3.3.1	Testing of actual size member for tensile strength	79
3.3.2	Testing of actual size members for bucking	80

	strength	
3.3.3	Testing of actual size members for flexural strength	81
3.4	Preparation of pultruded cross arm members with sheds	82
3.4.1	Development of end fittings for cross arm members	82
3.4.2	Assembly of cross arm with composite members	85
3.4.3	Mechanical testing of cross arm assembly with composite members	86
3.4.4	Testing procedure in reliability and security condition	87
3.5	Mechanical performance test of X-braced tower sub assembly	88
3.5.1	Mechanical performance of X-braced tower sub assembly with cross arm	91
3.6	Construction and testing of full scale tower with composite members for mechanical performance	94
3.7	Testing of full scale tower with composite members	99
3.7.1	Procedure of testing full scale tower with composite members	103
3.7.2	Testing for reliability condition	107
3.7.3	Testing for security conditions	107
3.7.4	Testing for safety conditions	107
3.8	Testing of cross arm and tower with composite members for electrical insulation and flash over	108
Chapter 4 RESULTS AND DISCUSSIONS		
4.1	Results of testing GE pultruded material	114
4.2	Results of testing tower member	120
4.3	Results of testing end clamps in of cross arm members	121
4.4	Results of testing cross arm for mechanical performance	123
4.5	Results of testing tower units / sub assembly	127

4.6	Results of testing tower units / sub assembly with cross arm mounted	134
4.7	Results of full tower testing for mechanical performance	139
4.8	Results of testing cross arm for electrical performance	148
4.9	Results of full tower testing for electrical performance	150
4.10	Savings in ROW and tower height with proposed tower of composite members	152
4.11	Savings in weight of the tower	154
Chapter 5	CONCLUSIONS	155
References		158

LIST OF FIGURES

Figure		Page No.
Figure 1.1	General configuration of power transmission and distribution network	2
Figure 1.2	Photograph showing components of an overhead transmission line	4
Figure 1.3	Classification of towers (CBIP Manual No. 268)	5
Figure 1.4	Types of transmission line towers	5
Figure 1.4(a)	Single circuit	5
Figure 1.4(b)	Double circuit	5
Figure 1.4(c)	Quadruple circuit	5
Figure 1.4(d)	Suspension tower	6
Figure 1.4(e)	Tension tower	6
Figure 1.4(f)	Dead end tower	6
Figure 1.4(g)	Self supported	7
Figure 1.4(h)	Guy supported	7
Figure 1.4(i)	Lattice tower	8
Figure 1.4(j)	Pole	8
Figure 1.4(k)	Horizontal	9
Figure 1.4(l)	Vertical	9
Figure 1.4(m)	Delta	9
Figure 1.5	Components of a typical tower	9
Figure 1.6	A typical double circuit tower showing the various components and electrical clearances	11
Figure 1.7	Electrical clearance diagram of 66kV conventional suspension tower	14
Figure 1.8(a)	Typical loads on a tower (Murthy and Santhakumar 1990)	15
Figure 1.8(b)	Typical loads on a transmission line tower	16
Figure 1.9	Basic wind speed for 50 year return period (IS:875 Part 3:1988)	18
Figure 1.10	Transverse load on the cross arm due to line deviation (Murthy and Santhakumar 1990)	19
Figure 1.11	Wind span and weight span (Murthy and Santhakumar 1990)	20
Figure 1.12	Electrical clearance requirement (IS:5613 Part 2-1985)	24
Figure 1.13	Schematic of the pultrusion process	28
Figure 1.14	Shapes of various members made with pultruded process	28
Figure 2.1	Attributes of tower with composite members for 66kV D/C line	34
Figure 2.2	Vertical spacing between cross arms	37
Figure 2.3	Location of earth wire with shielding angle	39
Figure 2.4	Tower with composite members for 66kV D/C compared with a conventional tower	41
Figure 2.5	External loads and wind loads acting on tower with composite members	43
Figure 2.6(a)	Loading trees for wind zone 4 (200m)	48

Figure 2.6(b)	Loading trees for wind zone 4 (200m)	49
Figure 2.7	Schematic arrangement of cross arm attached to the tower body	52
Figure 2.8	Geometric model of full tower and GE pultruded members selected	54
Figure 2.9	FE mesh for cross arm with loads and boundary conditions	58
Figure 2.10	Geometric models of tower units/sub assembly	61
Figure 2.10(a)	TS1	61
Figure 2.10(b)	TS2	61
Figure 2.10(c)	TS3	61
Figure 2.11	FE mesh with loads and boundary conditions for three tower sub units/assembly	62
Figure 2.11(a)	TS1	62
Figure 2.11(b)	TS2	62
Figure 2.11(c)	TS3	62
Figure 2.12	Geometric models of tower sub assembly with cross arm	64
Figure 2.12(a)	TSCA-1	64
Figure 2.12(b)	TSCA-2	64
Figure 2.13	FE mesh with loads and boundary conditions for tower sub assembly with cross arm	65
Figure 2.13(a)	TSCA-1	65
Figure 2.13(b)	TSCA-2	65
Figure 2.14	3-D geometric model of 66kV double circuit full scale tower	66
Figure 2.15(a)	Loads and boundary conditions applied on full scale tower	67
Figure 2.15(b)	FE model represents loading direction under reliability condition	68
Figure 3.1	Pultrusion process for fabricating composite members	70
Figure 3.1(a)	Fibre glass roving going into pultrusion process	70
Figure 3.1(b)	Pultrusion set up	70
Figure 3.2 a and b	Dimension of suggested tensile test specimen in ASTM D638-08	74
Figure 3.2(a)	Rectangle section	74
Figure 3.2(b)	Circular section	74
Figure 3.2 c and d	Photograph showing tensile test specimens of on GE pultruded members	74
Figure 3.2(c)	Rectangle section	74
Figure 3.2(d)	circular section	74
Figure 3.3	Photograph showing tensile strength test set up	75
Figure 3.4(a)	Photograph showing test set up	75
Figure 3.4(b)	Photograph showing specimen under compression test	75
Figure 3.5	GE pultruded sample mounted on flexural test – up	75
Figure 3.6(a)	Test set up of accelerated weathering test	76
Figure 3.6(b)	Picture of test specimens mounted on the specimen holder	76
Figure 3.7	Test set up for erosion test	77
Figure 3.8(a)	Erosion test with nozzle at 90 degree	78
Figure 3.8(b)	Erosion test with nozzle at 45 degree	78

Figure 3.9(a)	Test specimen immersed Apparatus for applying in oil bath for dielectric testing	78
Figure 3.9(b)	Apparatus for applying voltage in di–electric strength test	78
Figure 3.10	Pictures showing tensile strength tests of tower members	79
Figure 3.10(a)	Load cell	79
Figure 3.10(b)	Square hollow member	79
Figure 3.10(c)	Rectangular member	79
Figure 3.10(d)	Circular rod	79
Figure 3.11	Picture showing test for bucking strength of members with cross sections	80
Figure 3.11(a)	Angle	80
Figure 3.11(b)	Circular	80
Figure 3.11(c)	Rectangle	80
Figure 3.12	Picture showing flexural testing of members and	81
Figure 3.12(a)	Rectangle section	81
figure 3.12(b)	Circular section	81
Figure 3.12(c)	Test setup	81
Figure 3.13	Geometry of composite member used for cross arm showing rubber sleeve, end fitting and sheds	82
Figure 3.14	Photograph of composite cross arm member with end fittings	83
Figure 3.15	Crimping machine set up	83
Figure 3.16	Composite cross arm element showing crimped end fittings	83
Figure 3.17	Picture showing cross arm members with end clamps tested for strength	84
Figure 3.17(a)	With crimped metallic end fittings and weather sheds	84
Figure 3.17(b)	with adhesive bonded metallic end fitting without weather sheds	84
Figure 3.17(c)	Dynamic strain recorder set up	84
Figure 3.17(d)	End clamps with crimping remaining intact after loading	84
Figure 3.17(e)	End clamps with adhesive bonding slipping early during loading	84
Figure 3.18	Font and top view of composite cross arm assembled from pultruded composite members	85
Figure 3.19(a)	Schematic diagram of cross arm mounted on tower for mechanical testing	86
Figure 3.19(b)	Photograph of cross arm with composite members subjected to mechanical testing	87
Figure 3.20	Schematic view	88
Figure 3.20(a)	X-braced tower unit / assembly	88
Figure 3.20(b)	Details of connections to leg members	88
Figure 3.21	Schematic of test set up for tower sub assembly	89
Figure 3.22	Photograph showing the mechanical testing of tower sub assembly	90
Figure 3.22(a)	TSA-1	90
Figure 3.22(b)	TSA-2	90

Figure	3.22(c)	TSA-3	90
Figure	3.23	Photograph showing mechanical testing of X-braced tower unit with cross arm prototype TSCA -2	91
Figure	3.24(a)	Schematic of strain gauge locations on the cross arm members	92
Figure	3.24(b)	Schematic of strain gauge locations on the tower units/sub assembly members	92
Figure	3.25	Strain measurements on the tower unit/ sub assembly with cross arm	93
Figure	3.25(a)	Photograph of a typical strain gauge mounted on GE pultruded rod of cross arm	93
Figure	3.25(b)	Photograph showing gauges mounted on leg member(TSCA2)	93
Figure	3.25(c)	Photograph showing strain gauge mounted on leg member(TSCA3)	93
Figure	3.26	Output of strains in lab view corresponding to loading	94
Figure	3.27	Photograph showing	95
Figure	3.27(a)	Assembly of composite tower –leg member and bracing	95
Figure	3.27(b)	Typical joint details of leg member and bracing	95
Figure	3.28(a)	Schematic of a cross arm member joined to tower at leg member	96
Figure	3.28(b)	Photograph showing the joining of cross arm member with leg members	96
Figure	3.29	Photograph showing details	97
Figure	3.29(a)	Connection at the tip of cross assembly	97
Figure	3.29(b)	Connections at base portion of the cross arm	97
Figure	3.30	Photograph showing constructed full size (15 m) tower with composite members	97
Figure	3.31	Photograph showing tower mounted on rigid footings in testing station	99
Figure	3.32	Loading arrangement	100
Figure	3.32(a)	Transverse	100
Figure	3.32(b)	Longitudinal	100
figure	3.32(c)	Vertical	100
Figure	3.33	Photograph showing the tower and loading arrangements	101
Figure	3.34	Details of tower testing	102
Figure	3.34(a)	Photograph showing stack of calibrated load cells	102
Figure	3.34(b)	Photograph showing load cells attached	102
Figure	3.34(c)	Photograph showing loading winches	102
Figure	3.34(d)	Photograph showing the control panel	102
Figure	3.35	Photograph showing graduated scales fixed at the tip of tower and cross arms	103
Figure	3.36	Three rosette strain gauges mounted for strain measurement during testing	104
Figure	3.36(a)	Near the bottom of leg member	104
figure	3.36(b)	Near the base of cross arm member	104
Figure	3.37	Power frequency test	109

Figure 3.37(a)	Voltage application system	109
Figure 3.37(b)	Photograph showing wet condition of cross arm	109
Figure 3.37(c)	Photograph showing wet condition of full scale tower	109
Figure 3.38	Impulse voltage test	111
Figure 3.38(a)	Test set up	111
Figure 3.38(b)	Photograph showing live conductor attached to the composite cross arm during impulse voltage test	111
Figure 3.38(c)	Photograph showing live conductor attached to the composite cross arm and tower with composite members	112
Figure 3.38(d)	Snap shot of lightning impulse voltage/time curve(+polarity)	112
Figure 3.38(e)	Snap shot of lightning impulse voltage/time curve (-polarity)	112
Figure 3.38(f)	Snap shot of lightning impulse voltage/time curve (+polarity) for full tower with cross arm	113
Figure 3.38(g)	Snap shot of lightning impulse voltage/time curve (-polarity) for full tower with cross arm	113
Figure 4.1	Typical longitudinal stress versus strain graph for pultruded members	115
Figure 4.1(a)	Rectangular section	115
Figure 4.1(b)	Circular section	115
Figure 4.2	Typical failure modes	116
Figure 4.2(a)	Samples of rectangle section	116
Figure 4.2(b)	Samples of circular section	116
Figure 4.3	Typical failure modes in compression test	117
Figure 4.4	Flexural load versus displacements plots obtained during flexural test	117
Figure 4.5	Photograph showing typical observed in flexural test of GE pultruded samples	118
Figure 4.6	Load versus strain behaviour with metallic clamps	122
Figure 4.7(a)	Post processor plot showing maximum displacement of cross arm under combined transverse, vertical and longitudinal loads	123
Figure 4.7(b)	Post processor plot showing maximum stresses in the cross arm members under combined transverse, vertical and longitudinal loads	124
Figure 4.8	Load versus strain behaviour of cross arm members	124
Figure 4.9(a)	Maximum deformations in member of prototype TS1 (Table 2.23) using circular section bracing with solid rectangular leg member	127
Figure 4.9(b)	Maximum stresses in members of prototype TS1 (Table 2.23) using circular section bracing with solid rectangular leg member	128
Figure 4.10(a)	Maximum deformations in member of prototype TS2 (Table 2.23) using circular section bracing with solid rectangular leg member	128
Figure 4.10(b)	Maximum stresses in members of prototype TS2 (Table	129

	2.23) using circular section bracing with solid rectangular leg member	
Figure 4.11(a)	Maximum deformations in member of prototype TS3 (Table 2.23) using angle section bracing with hollow square leg member	129
Figure 4.11(b)	Maximum stresses in members of prototype TS3 (Table 2.23) using angle section bracing with hollow square leg member	130
Figure 4.12(a)	Load versus strain plot in different members of prototype TS1	131
Figure 4.12(b)	Load versus strain plot in different members of prototype TS2	131
Figure 4.12(c)	Load versus strain plot in different members of prototype TS3	132
Figure 4.13	Buckling observed in leg and bracing member of tower sub assembly model TS1 in FEA	133
Figure 4.14	Photograph showing buckling of leg and bracing of tower sub assembly prototype TS1 during testing	133
Figure 4.15(a)	Maximum deformations observed in members of prototype TS2CA tower unit with cross arm	134
Figure 4.15(b)	Maximum stresses observed in the bracing members of prototype TS2CA tower unit with cross arm	135
Figure 4.16(a)	Maximum deformations observed in members of prototype TS3CA tower unit with cross arm	135
Figure 4.16(b)	Maximum stresses observed in the joints of bracing members of prototype TS3CA tower unit with cross arm	135
Figure 4.17	Load versus strain plot in different members of prototype TS2CA	137
Figure 4.18(a)	Maximum stresses observed at the bolt hole at the bracing members prototype TS3CA tower unit with cross arm	138
Figure 4.18(b)	Photograph showing failure of bracing member at bolt hole (TS2CA)	138
Figure 4.19(a)	Maximum deformations observed in members of full tower under load case 2 security condition – Earth wire broken	139
Figure 4.19(b)	Maximum stresses observed in members of full tower under load case 2 security condition – Earth wire broken	140
Figure 4.20	Photograph showing deflection of tower under load case 2 security condition – Earth wire broken during tower testing	141
Figure 4.20(a)	Transverse direction	141
Figure 4.20(b)	Longitudinal direction	141
Figure 4.21	Tower height versus deflection	144
Figure 4.22(a)	Cracking of leg member at the base of top cross arm	147
Figure 4.22(b)	Bolt sheared off at the joint between leg and bracing	147
Figure 4.23(a)	Lightning impulse voltage/time curve for 66kV composite cross arm	148
Figure 4.23(b)	Lightning impulse voltage/time curve for 66kV composite cross arm	149

Figure 4.23(c)	Lightning impulse voltage/time curve for 132kV composite cross arm	149
Figure 4.24(a)	Lightning impulse voltage/time curve for 66kV tower and cross arm with composite members	150
Figure 4.24(b)	Lightning impulse voltage/time curve for 66kV tower and cross arm with composite members	151
Figure 4.25	ROW requirement	152
Figure 4.26(a)	Conventional steel tower	153
Figure 4.26(b)	Proposed tower with composite members	153

LIST OF TABLES

Table		Page No.
Table 1.1	Insulator swing angle and air clearances for various line voltages (IS:5613 Part 2-1985)	13
Table 1.2	Reliability levels of transmission lines (IS:802 (Part 1/Sec 1):1995)	16
Table 1.3	Basic wind speed (IS:875 Part 3:1988)	18
Table 1.4	Risk coefficient K1 for different reliability levels and wind zones (IS:802 Part 1/Sec 1:1995)	19
Table 1.5	Terrain roughness coefficient K2 (IS:802 Part 1/Sec 1:1995)	19
Table 1.6	Right of way requirement (IS:5613 part 2:1985)	25
Table 2.1	Properties of conductor and earth wire (IS: 398 and IS: 2141)	36
Table 2.2	Sag –Tension values calculated for conductor and earth wire under different temperature and wind conditions (IS: 5613 Part 2 – 1985)	36
Table 2.3(a)	Loads under reliability conditions	45
Table 2.3(b)	Loads under security conditions	46
Table 2.3(c)	Loads under safety conditions	47
Table 2.3(d)	Summary of calculated loads as per IS:802 Part 1/Sec 1 – 1995 for a 66 kV tower	47
Table 2.4(a)	Compressive strength and ultimate loads for different GE pultruded members	50
Table 2.4(b)	Compressive strength and ultimate loads for different GE pultruded members	51
Table 2.5	GE pultruded sections selected for full scale tower	53
Table 2.6(a)	Member design chart for full scale tower	55
Table 2.6(b)	Member design chart for full scale tower	56
Table 2.6(c)	Member design chart for full scale tower	57
Table 2.7	Material properties used for FE Analysis	58
Table 2.8	FE models of X-braced tower sub units / assembly	59
Table 2.9	FE models of X-braced tower sub assembly with cross arm	63
Table 3.1	Properties of E-glass and Epoxy resin	69
Table 3.2	Details of GE pultruded cross arm and tower members	71
Table 3.3	Details of three prototypes of X-braced tower unit/sub assembly	88
Table 3.4	GE pultruded members used for composite tower	94
Table 3.5	Tower testing loading sequence IS:802 (part 3)	98
Table 3.6	Suggested minimum values for power frequency withstand voltage and lightning impulse withstand voltage as per IS:2165(part 2): 1983	106
Table 4.1	Results of test for density and percentage of water absorption	114
Table 4.2	Results of tensile test and other computed properties of GE pultruded material	115
Table 4.3	Results of compression test	116
Table 4.4	Results of flexural test	117
Table 4.5	Test results of accelerated weathering test	118
Table 4.6	Loss of tensile strength result due to accelerated weathering	119
Table 4.7	Results of erosion test before and after weathering	119
Table 4.8	Results of di-electric strength test on GE pultruded members	120
Table 4.9	Load carrying capacity of tower members determined from tests	121
Table 4.10	Results of bonding strength test on cross am member	122
Table 4.11	Deflections measured from experiment at cross arm tip	125

Table	4.12	Comparison of forces in cross arm members	126
Table	4.13	Comparison of experimental and FEA strains of cross arm members	126
Table	4.14	Comparison of experimental and FEA results	132
Table	4.15	Comparison of experimental and FEA results	137
Table	4.16	Measured deflection under reliability condition	141
Table	4.17	Measured deflection under security condition – Earth wire broken	142
Table	4.18	Measured deflection under security condition – Top conductor broken	142
Table	4.19	Measured deflection under security condition – Middle conductor broken	143
Table	4.20	Measured deflection under security condition – Bottom conductor broken	143
Table	4.21(a)	Table comparing deflections at earth wire peak obtained from FEA and experiments	144
Table	4.21(b)	Table comparing deflections at top cross arm obtained from FEA and experiments	145
Table	4.21(c)	Table comparing deflections at middle cross arm obtained from FEA and experiments	145
Table	4.21(d)	Table comparing deflections at bottom cross arm obtained from FEA and experiments	146

NOMENCLATURE

ROW	Right of Way
h_1	Minimum permissible ground clearance
h_2	Maximum sag
h_3	Vertical spacing between conductors
h_4	Vertical spacing between earth wire and top conductor
K_1	Risk coefficient
P_s	Minimum yearly reliability
K_2	Terrain roughness coefficient
P_d	Design wind pressure in kg/m^2
V_d	Design wind speed in m/s
T	Tension in the conductor / Earth wire
Θ	Angle of deviation of the line
F_{wc}	Transverse wind load on conductor/earth wire in N
d	Diameter of conductor / earth wire in m.
F_d	Transverse load due to conductor/earth wire tension in N
F_{d_l}	Longitudinal load due to conductor/earth wire tension in N
f	Working tensile stress of conductor in kg/cm^2
K	Constant computed from initial temperature and wind pressure conditions assumed.
E	Final modulus of elasticity in kg/cm^2
α	Coefficient of linear expansion of conductor per $^{\circ}\text{C}$
δ	Weight of conductor /m/cm ²
t	Change of temperature in $^{\circ}\text{C}$
l	Span length in m
q	Loading factor
A	Cross sectional area of conductor in cm^2
W	Weight of conductor in kg/m length of conductor
P	Wind load on conductor in kg/m length of conductor
H	Height of hanger
α	Angle between inclined member of cross arm and lower main member of the cross arm
S	Length of suspension string
\emptyset_1	Minimum swing angle of the suspension string
\emptyset_2	Maximum swing angle of the suspension string
X_1	Electrical clearance corresponding to swing angle \emptyset_1
X_2	Electrical clearance corresponding to swing angle \emptyset_2
B	Flange width of the nearest projecting angle sections connected to main angle members
C	Distance of centre of gravity of the main angle sections from the heel of angle Member
C_{dt}	Drag coefficient
A_e	Total net surface area of the legs, bracings, cross arms and secondary Members of the panel projected normal to the face in m^2
G_T	Gust response factor peculiar to the ground roughness and depends on the height above ground.

L	Wind span, being sum of half the span on either side of supporting point in m
G_c	Gust response factor, taken into account the turbulence of the wind and the dynamic response of the conductor.
A_x	Exposed area of cross arm
G_x	Gust response factor
P_{euler}	Euler buckling load
E	Compressive longitudinal modulus of the pultruded section
I	Second moment of area about minor axis of the profile
k	End-restraint coefficient
$(kL/r)_{max}$	Maximum slenderness ratio of the element,
k_{tim}	Timoshenko shear coefficient
A_z	Cross sectional area
T	Transverse load
γ	Angle included between the two main members of cross arm in horizontal plane
V	Vertical load
β	Angle included between the tie and main members of cross arm in vertical plane
L	Longitudinal load
W	Breaking load (N)
L	Span between supports (mm)
B	Width (mm)
D	Thickness (mm)
r	Radius of circular section

CHAPTER 1

INTRODUCTION

1.0 OVERVIEW OF ELECTRICAL TRANSMISSION

Electric power is playing an increasingly important role in development of community and economy. In fact, the economy is becoming increasingly dependent on electricity as a basic input. Developing countries like India are therefore giving high priority to power generation and transmission. The economic importance of electricity was recognized early and legislation was enacted to create Central Electricity Authority (CEA) and State Electricity Boards (SEB) for development and implementation of efficient electric power generation and transmission. Importance was given for these organisations in every five year plan beginning from First Five-Year Plan (Murthy S.S. et al. 1990). In Indian power scenario focus continues to be on the efficient transmission which is a major cost driver.

Transmission of electric power has been there since decades and will still continue to be most important in driving the energy economy. The prime purpose of transmission line is to transmit electricity from power plant to a substation and to either domestic or industrial utility. In the early days of electrification, power plants were small and generated electricity for areas in the immediate vicinity. As the demand for electricity increased, larger and more efficient power plants are developed which required transmission lines to carry energy over long distances (Kiessling F. et al. 2002). The transmission network enables transport of energy from point of generation to the utility efficiently and economically.

The general configuration of power transmission network is shown in Figure 1.1.

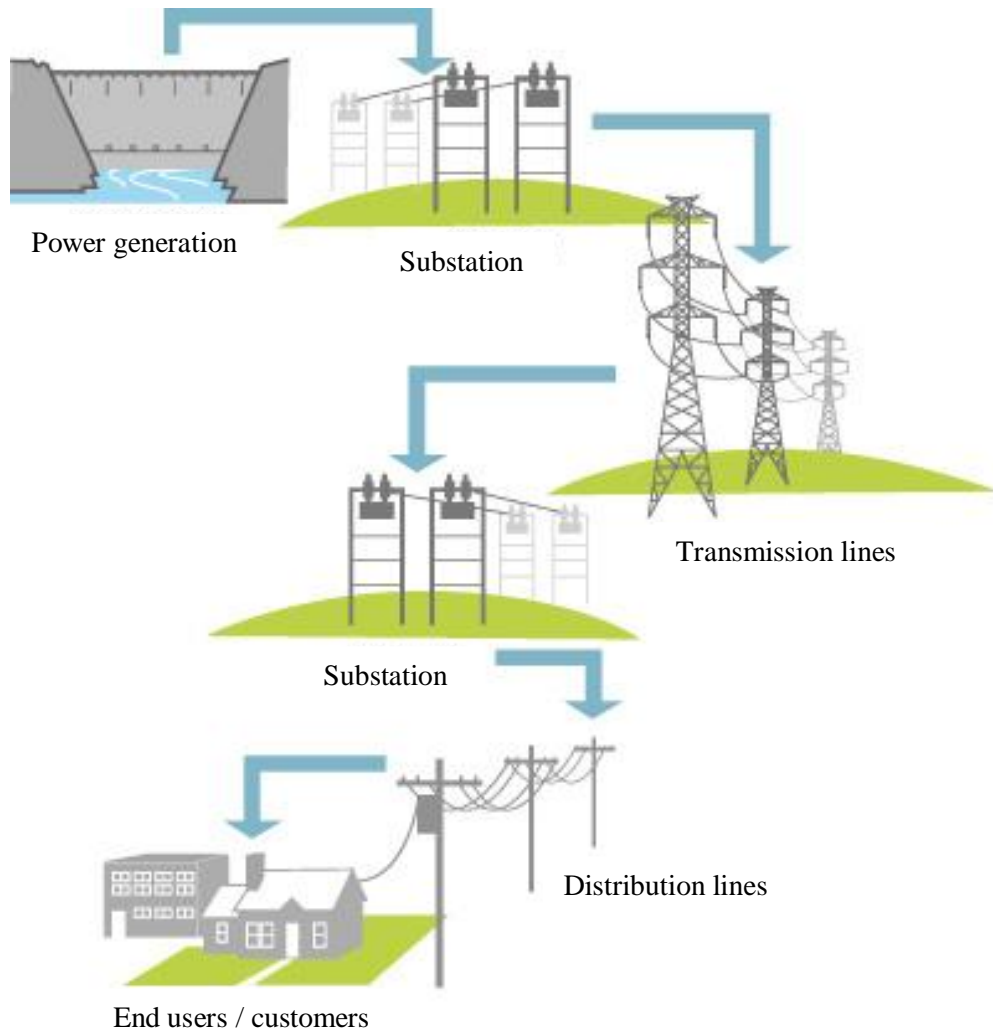

Fig. 1.1 General configuration of power transmission and distribution network

As evident in the above configuration, transmission lines run between sub-stations separated by large distances of various terrains and contribute to major portion of transmission cost. These lines are installed and maintained for longer years of service anywhere between 50 and 150 years IS:802 (Part 1):1995, IEC 60826-1 (1991).

1.1 FEATURES OF TRANSMISSION LINES

The growth of transmission networks in India is increasing manifold on account of increasing demand for electrical energy and is so projected for next few decades. Thus the development of new technology for design and implementation of transmission system meeting this growth is a challenge faced presently by the technologists.

The types of transmission lines could be either overhead or underground. It is important to note the pros and cons of building transmission lines either overhead or underground in order to achieve economy and efficiency. Overhead lines do not disturb sensitive features such as cultural resources sites, streams, wetlands, steep slopes etc., while as underground transmission lines cost several times more than the overhead transmission as they require construction of a trench which also results in disturbance in an area of about 40 feet wide along the line. In addition to the cost, the key difference between underground and overhead lines is the time to locate, diagnose and repair which is more for underground transmission lines. Overhead transmission lines have very high reliability because of their physical design. Placing transmission line underground is resorted only when a suitable corridor cannot be identified such as in city/urban areas or near airports. Owing to their simplicity, cost and other advantages overhead lines popular and used widely (Kiessling F. et al. 2002).

A typical schematic of overhead power transmission line and its components is presented in Figure 1.2. Transmission line consists of towers, conductors, earth wires, insulators and foundations. Tower being a major member in the system drives the economics of transmission line. Thus, lately lot of focus is drawn on improvising the tower designs to achieve economical and efficient transmission lines.

The transmission lines are designed in such a way that the power conductors are supported on towers erected along the route. The transmission line conductors are clamped to the insulators which in turn are attached to the tower cross arms (Figure 1.2). The power conductors are insulated from tower through necessary insulation systems (Murthy S.S. et al. 1990). The most commonly used insulation is porcelain insulators assembled in the form of insulator strings. These insulate the charged conductors from metal parts and provide adequate spacing between conductors and earth wire for insulation and prevent arcing.

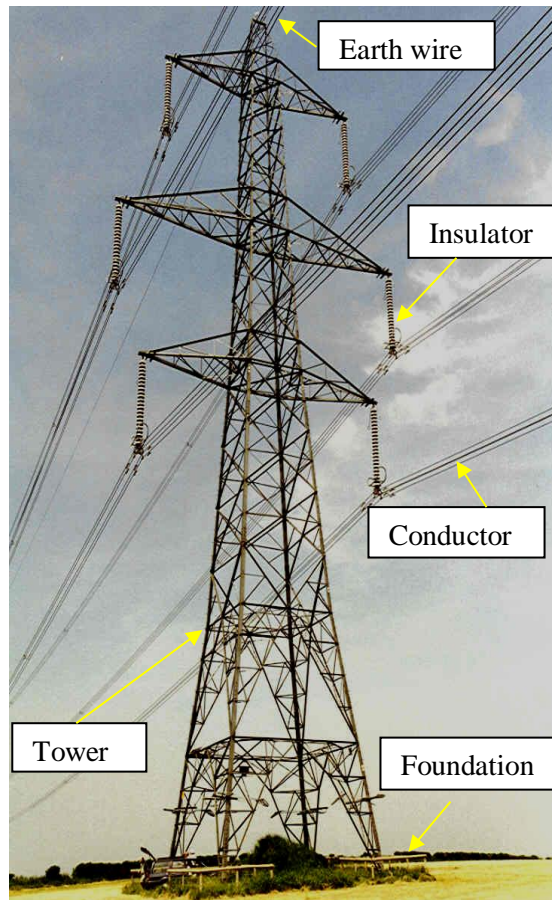

Fig 1.2 Photograph showing components of an overhead transmission line

1.2 TYPES AND FEATURES OF TOWERS

The tower in an overhead power transmission line typically comprises of foundations, body and supports for conductors and earth wires. The role of the tower is to keep power conductors at the safe distance from one another and from ground. Also they need to withstand the conductor tension, weight and external loads like wind loads. The selection of suitable towers for transmission lines depends on the terrain through which the line traverses. The selection is governed by transmitted voltage, the number of circuits, the height and looks of the tower and other aspects like operational reliability, investments and material of the tower.

Few standard tower designs are prevailing to ensure an overall economy of installation and maintenance; these are classified as presented in Figure 1.3.

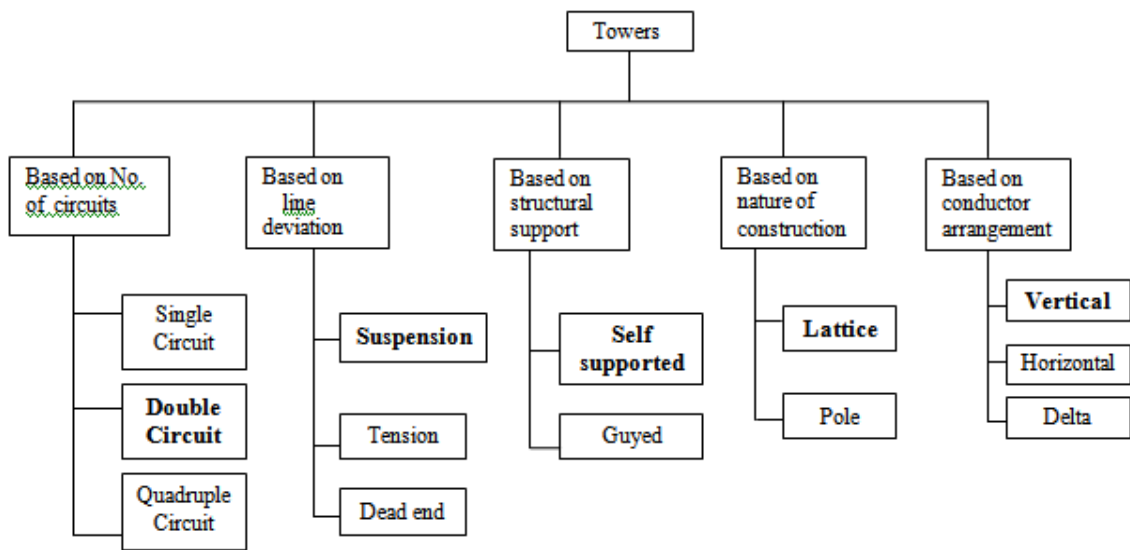

Fig. 1.3 Classification of towers (CBIP Manual No.268)

The transmission line towers are classified based on the number of circuits, line deviation, and structural support, nature of construction and conductor arrangement. Figure 1.4a,b and c shows the typical single circuit, double circuit and quadruple circuit transmission line tower. The number circuit is decided based on the power transmission capacity of the lines.

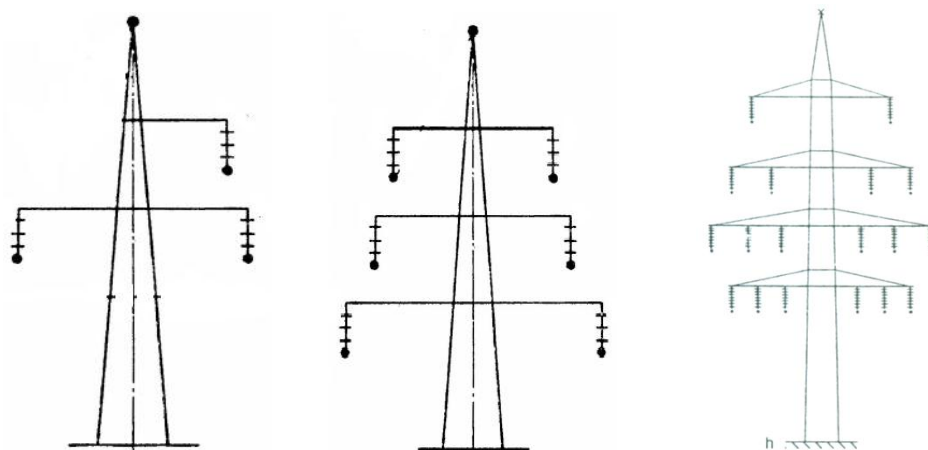

Fig. 1.4 (a). Single circuit (b). Double circuit (c). Quadruple circuit

Figure 1.4 d,e,and f shows the typical transmission line route consists of suspension, tension and dead type towers, suspension towers carry the conductors in a straight line or with a deviation of 2° to 5° . The suspension towers are designed relatively light weight because they do not transfer conductor tensile forces to the towers during normal operation. 80 to 90 % of the transmission line is composed of suspension type towers. Thus design of suspension tower provides the opportunity for the structural engineer to develop optimum design.

Tension towers carry the resulting conductor tensile forces where the line changes the direction at an angle. Tension towers are used at location where the angle of deviations is larger than permissible with suspension towers. These towers are further classified as $2^{\circ}/5^{\circ}$ - 15° (light angle), 15° - 30° (medium angle), 30° - 60° / Dead End (heavy angle) towers and are used according to the angle of line deviation.

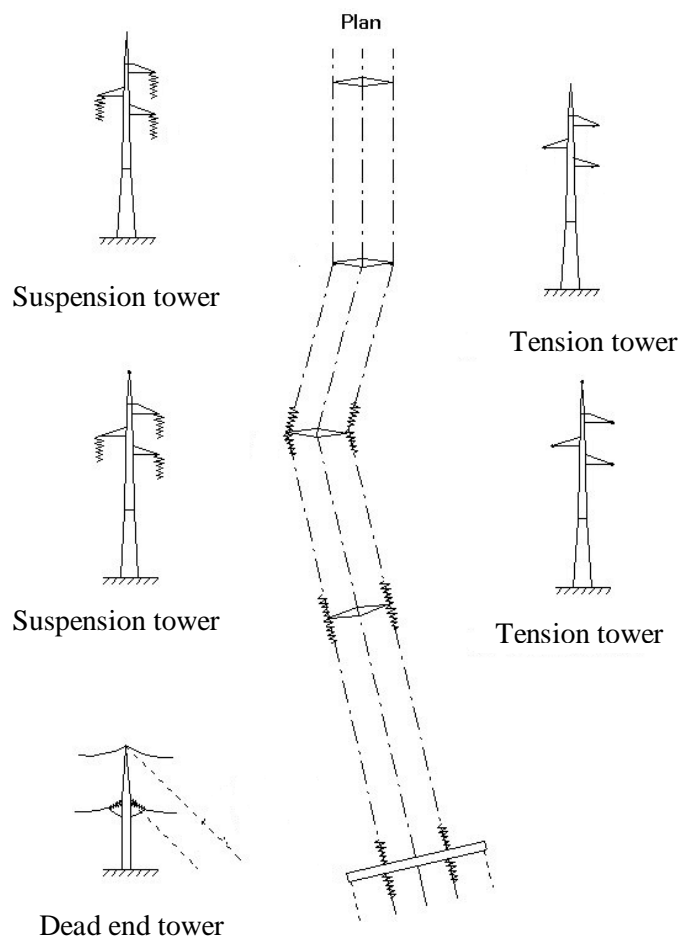

Fig. 1.4 (d). Suspension tower (e). Tension tower (f). Dead end tower

Dead end towers are designed to resist conductor /earth wire pulls on one side. In addition to their use for large angles, the dead end towers are used as terminal towers i.e., before substation or for sectionalizing a long line consisting of suspension towers. Sectionalizing provides a longitudinal strength to the line and is generally recommended every 10 miles. Dead end towers are also used for resisting uplift loads. Figure 1.4 g and h shows the typical self-supported and guyed tower, self-supporting towers are the most traditional types used in overhead power lines, they are predominantly adopted where the requirements due to local conditions and the environment calls for narrow tower locations and right of way (ROW). Guyed towers are used especially in flat or easily accessible terrain for economical and aesthetic reasons. In agricultural areas, which are predominantly flat, guyed towers are used.

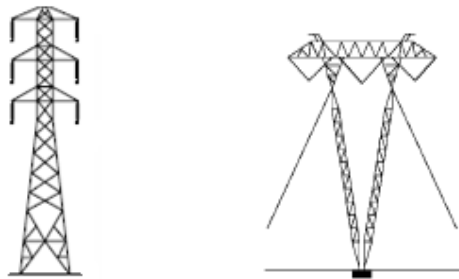

Fig. 1.4 (g). Self supported (h). Guy supported

Figure 1.4 i and,j shows the typical outline of lattice and poles types, lattice towers are the most commonly used in power lines. Their configuration can be adjusted to accommodate several circuits and types of conductor configurations and lattice towers are more economical. Pole types are frequently used in congested urban or suburban areas where Right of Way (ROW) availability is limited and short spans are possible.

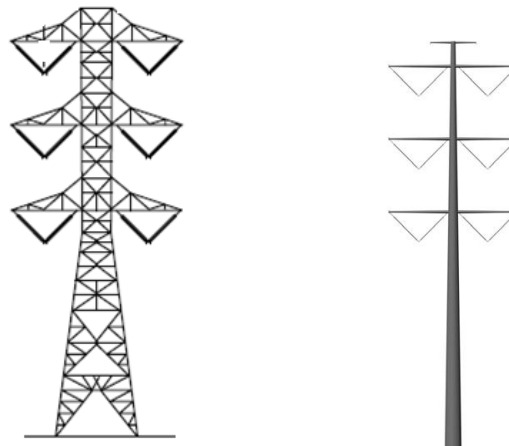
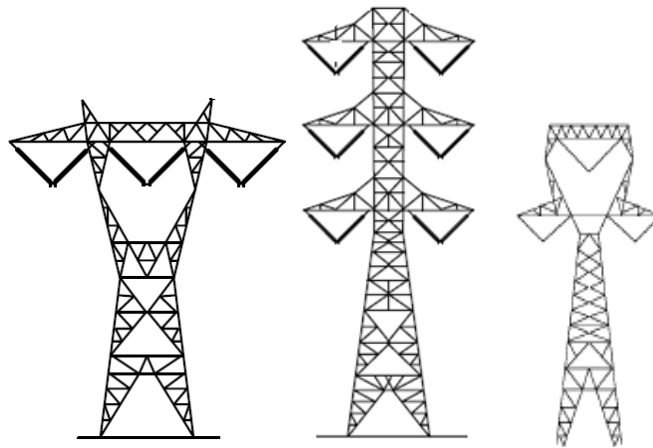

Fig. 1.4 (i). Lattice tower

(j). Pole

Figure 1.4 k,l,and m shows the vertical, horizontal and delta type towers based on conductor arrangement. Vertical configuration is used for double circuit lines whereas horizontal configuration with two earth wire is used for single circuit lines. Generally horizontal configuration results in lowest tower cost but require wider right-of-way (ROW) and more tree clearing.

If right-of-way costs are high, width of the right-of-way is restricted or the lines are running closely parallel, then vertical configuration may be yielding lower cost. Although vertical towers are narrower, they are taller, which may be objectionable some times. In general, vertical configurations will have lower electromagnetic field strengths at the edge of the right-of-way than horizontal configurations, and delta configurations will have least field strength in single-circuit but not in double-circuit.



(k). Horizontal (l). Vertical (m). Delta

Fig. 1.4 Types of transmission line towers

1.2.1 Components of a typical tower

Typical tower of an overhead power transmission line is shown in Figure 1.5. It consists of supports for earth wire peak, cage, cross arms, insulator strings and tower body.

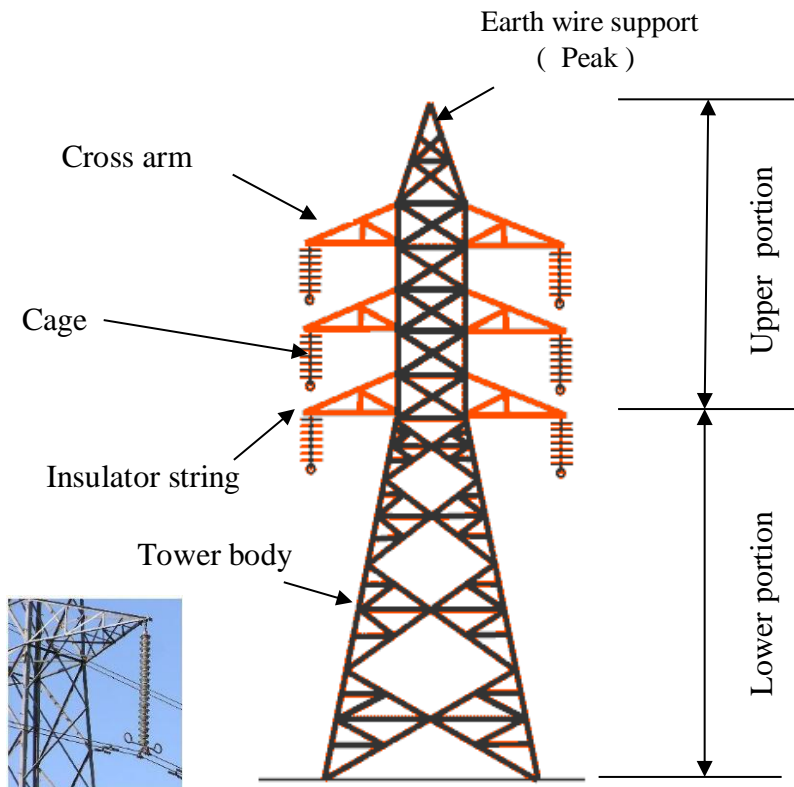

Fig. 1.5 Components of a typical tower (inset: insulator string)

1.2.2 Tower geometry

The geometric configuration of lattice transmission tower is based on earth wire shield coverage, number of circuits, conductor arrangement selected to satisfy the electrical clearance and right-of-way requirements. The development of tower configuration starts with upper portion. This section of tower is designed for maintaining mandatory vertical and horizontal clearances between each conductor. The lower portion of the tower is designed based on useful height, clearance from ground etc. The wider the tower base transmits lesser loads to foundation but increases the length and weight of bracing members. Therefore an optimum base width is adopted to determine the size of the bracing members.

Selecting the geometry and material for tower becomes critical part of cost-effective tower design. In depth structural analysis is to be performed to determine the most suitable tower configuration based on cost, maintenance and electromagnetic field considerations.

The important performance attribute of transmission line tower is to assure the reliability and security of the electric system. Besides the mechanical integrity of the tower, attention should be given to the electric performance that plays a main role in design. In order to achieve the above objective, optimum insulation clearances of the towers should be selected.

From safety considerations, power conductors along the route of the transmission line should maintain requisite clearances from ground in open country, national high ways, rivers, railway tracks, telecommunication lines, other power lines, etc., as laid down in the Clause No. 77 of Indian Electricity Rules :1956 or Indian standard IS:5613 (Part-2 / Sec-1) : 1985.

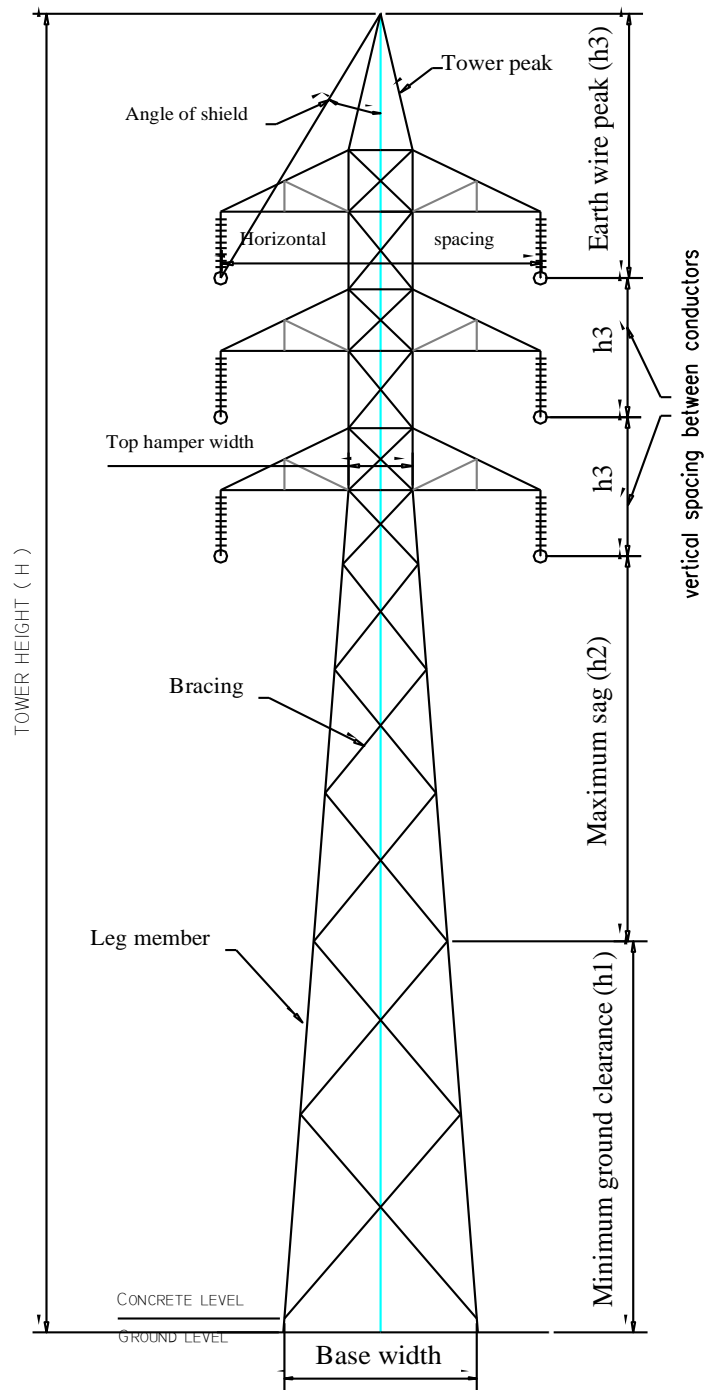

Fig. 1.6 A typical double circuit tower showing the various components and electrical clearances.

Accordingly, the minimum ground clearance for the various voltages from 66 kV to 400 kV is given below:-

66 kV - 5.50 m

132 kV - 6.10 m

220 kV - 7.01 m

400 kV - 8.84 m

Figure 1.6 shows the typical double circuit transmission line tower components with various electrical clearances. Tower geometry is determined based on consideration of electrical and mechanical aspects. The tower outline is determined essentially by three factors: tower height, base width and top hamper width. The factors governing the height of a tower are:

1. Minimum permissible ground clearance (h_1)
2. Maximum sag (h_2)
3. Vertical spacing between conductors (h_3)
4. Vertical spacing between earth wire and top conductor (h_4)

Total height of a tower in the case of vertical configuration double circuit tower is given by

$$H = h_1 + h_2 + h_3 + h_4 \quad (1.1)$$

The length of the tower cross arm is determined from the clearance diagram corresponding to the swing angle of insulator string and the minimum air clearance required from conductor point to steel tower. The electrical clearance diagram for a typical 66 kV double circuit tower with suspension insulators are shown in Figure 1.7 (CBIP Manual No.268).

There are two factors governing the swing of the insulator strings one is air clearances corresponding to different operating methods and other is climatic conditions.

Air clearance refers to the minimum distance which must be maintained between the live conductor and the earthed metal parts of the tower to avoid a flashover between them. The minimum air clearance is to be maintained even under the conditions of system overvoltage with the insulator strings in the deflected position due to the action of wind pressure. Like the insulator strings, the air clearance between the live

conductor and earthed metal part is also subjected to the various voltage stresses under different system conditions. The lower air clearance will adversely affect the full utilization of the line insulation provided, too large air clearance will mean longer cross arms and correspondingly heavier towers, thereby adding to the cost (Murthy S.S. and Santhakumar 1990). The swings and the corresponding clearances usually adopted at present for various transmission lines from 66 kV to 400 kV are given in Table 1.1.

Table.1.1 Insulator swing angle and air clearances for various line voltages (IS:5613 Part 2- 1985)

Line Voltage (kV)	Swing angle of suspension string from vertical (degrees)	Minimum clearance specified (mm)
66	30	760
	45	610
132	30	1525
	60	1070
220	20	1980
	35	1400
400	22	3000
	45	1860

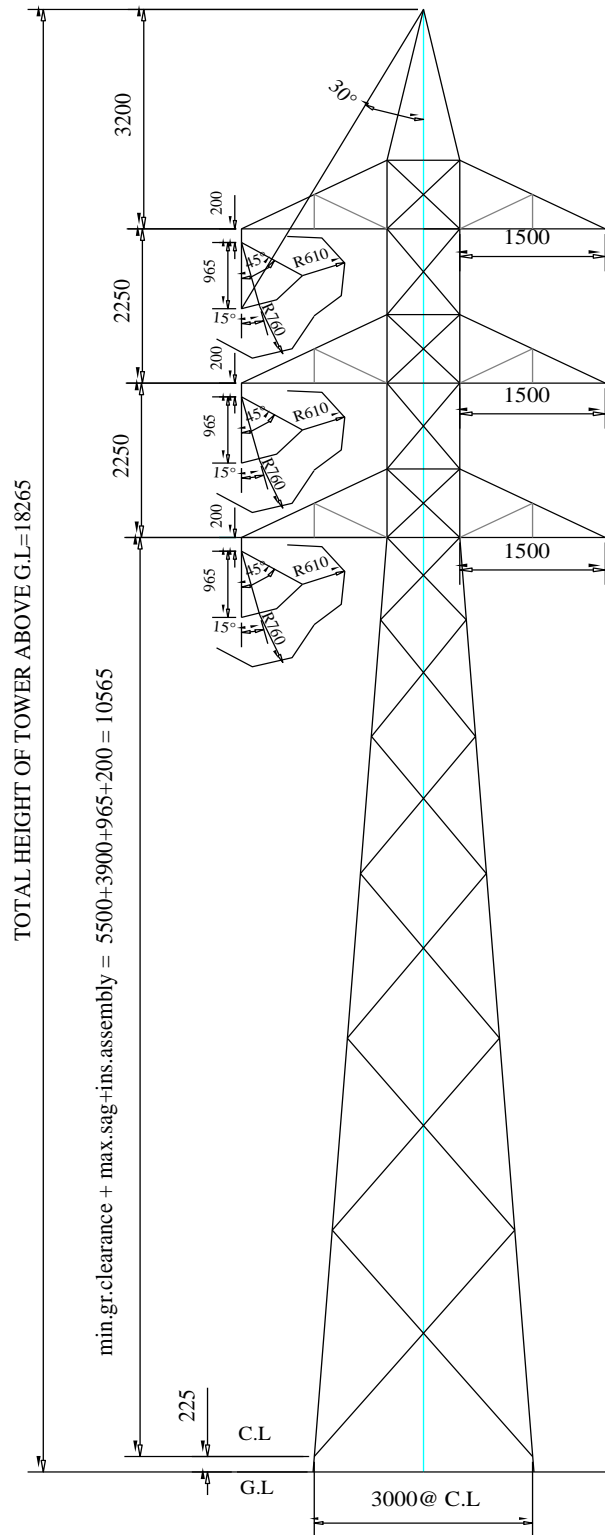

Fig. 1.7 Electrical clearance diagram of 66 kV conventional suspension tower

1.3 TOWER DESIGN

The design of transmission line tower is complex because of highly indeterminate nature and variety of loadings occurring in conditions such as cyclones, earthquakes and temperature variations and wind. Generally wind loads and conductor loads due to temperature variation are considered as external loads acting on the tower. These are determined for analysis of forces in various members which help in fixing up their sizes.

1.3.1 Loads on transmission line towers

Determination of loadings on a tower is most important part of tower design. Various types of loads are to be calculated accurately depending on the service condition. The various factors such as wind pressures, temperature variations and broken wires govern the nature and magnitude of loads on tower. The load on a tower is suggested in three mutually perpendicular vertical, transverse and longitudinal to the direction of line as shown in Figure 1.8 a,b.

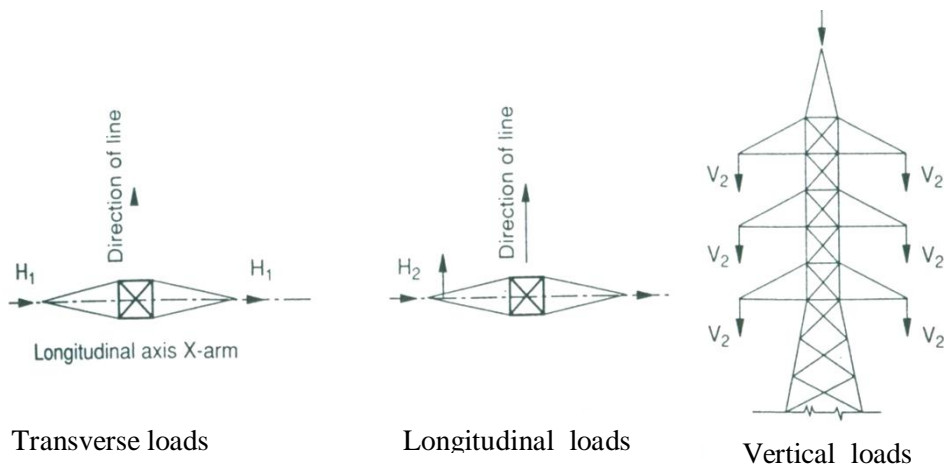

Fig. 1.8a Typical loads on a tower (Murthy S.S. and Santhakumar 1990)

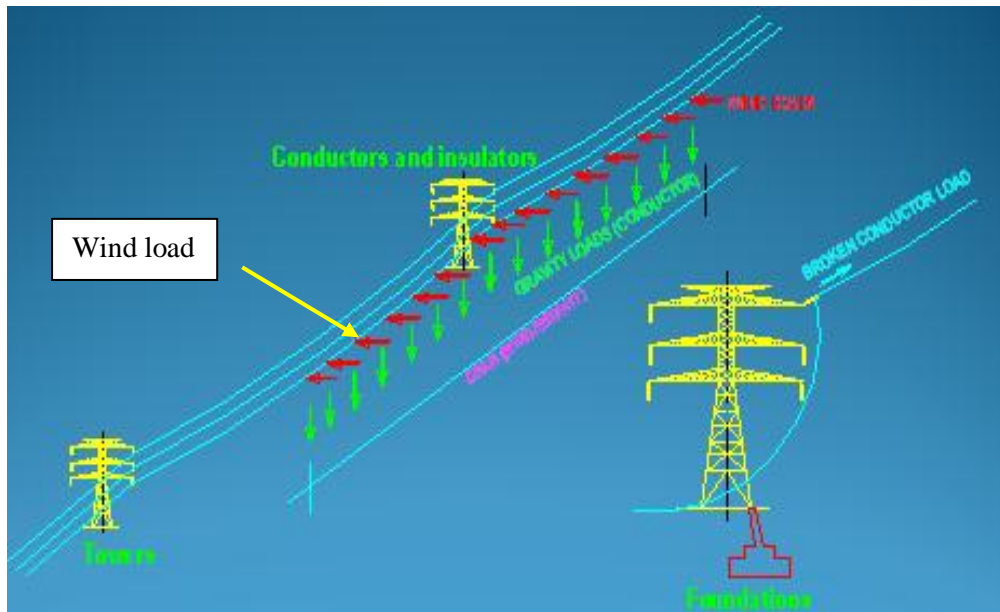

Fig. 1.8b Typical loads on a transmission line tower

Transmission line towers are designed based on reliability levels suggested in Table 1.2 (IS: 802 Part 1/ Sec 1:1995). These levels are expressed in terms of return periods in years of climatic (wind) loads. The minimum yearly reliability P_s , corresponding to the return period T , is expressed as $P_s = (1 - 1/2T)$.

Table. 1.2 Reliability levels of transmission lines (IS: 802 (Part 1/Sec 1):1995)

Sl.No	Description	Reliability Levels		
		Level 1	Level 2	Level 3
1	Return period of design loads, in years T	50	150	500
2	Yearly reliability P_s	$1-10^{-2}$	$1-10^{-2.5}$	$1-10^{-3}$

Reliability level 1 is adopted for transmission lines upto 400 kV, level 2 is adopted for more than 400 kV and level 3 is adopted for tall river crossing towers and special towers. In calculating wind loads, the effects of terrain, tower height, wind gust and tower shape are included.

Figure 1.9 shows basic wind speed map of India as applicable at 10 m height above mean ground level for six wind zones. Basic wind speed V_b is based on peak gust velocity averaged over short time interval of about 3 seconds, corresponding to mean heights above ground level in an open terrain (category 2) and have been worked out for a return period of 50 years return period (IS:875 Part 3:1988). Basic wind speeds for the six wind zones are listed in Table 1.3 :

Reference wind speed V_R is extreme value of wind speed over an averaging period of 10 minutes duration and is calculated from basic wind speed V_b by the following relationship

$$V_R = V_b / K_0 \quad (1.2)$$

Where K_0 is a factor to convert 3 seconds peak gust speed into average speed of wind during 10 minutes period at a level of 10 m above ground. K_0 is taken as 1.375 (IS:875 Part 3 : 1988)

$$\text{Design wind speed } V_d = V_R \times K_1 \times K_2 \quad (\text{IS:802 Part 1/Sec 1 : 1995}) \quad (1.3)$$

Where K_1 = Risk coefficient (Table 1.4) and

K_2 = Terrain roughness coefficient (Table 1.5)

The design wind pressure on towers, conductors and insulators are obtained by the following relationship:

$$P_d = 0.6 V_d^2 \quad (\text{IS: 802 Part 1/ Sec 1:1995}) \quad (1.4)$$

Where P_d = Design wind pressure in N/m^2 , V_d = Design wind speed in m/s



Fig. 1.9 Basic wind speed for 50 year return period (IS:875 Part 3:1988)

Table 1.3 Basic wind speed (IS:875 Part 3:1988)

Wind zone	Basic Wind Speed V_b m/s
1	33
2	39
3	44
4	47
5	50
6	55

Table 1.4 Risk coefficient K_1 for different reliability levels and wind zones
(IS: 802 Part 1/ Sec 1: 1995)

Reliability levels	Coefficient K_1 for wind zones					
	1	2	3	4	5	6
1	1.00	1.00	1.00	1.00	1.00	1.00
2	1.08	1.10	1.11	1.12	1.13	1.14
3	1.17	1.22	1.25	1.27	1.28	1.30

Table 1.5 Terrain roughness coefficient K_2 (IS: 802 Part 1/ Sec 1:1995)

Terrain category	1	2	3
Coefficient, K_2	1.08	1.00	0.85

1.3.1.1 Transverse loads

The transverse load consists of loads at the points of conductor and earth wire support in a direction parallel to the longitudinal axis of the cross arms, plus a distributed load over the transverse face of the tower due to wind. Transverse loads on conductor and earth wire are made up of the following components:

- Wind on the conductor/earth wire over the wind span.
- Angular component of a line tension due to an angle in the line
(Figure 1.10)

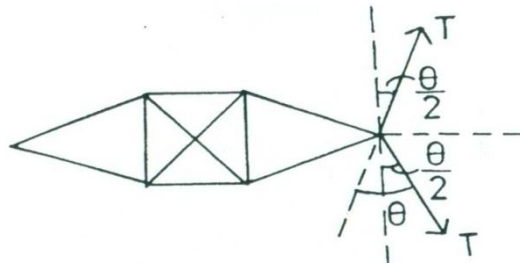

Fig. 1.10 Transverse load on the cross arm due to line deviation
(Murthy S.S. and Santhakumar 1990).

Where T – Tension in the conductor

Θ – Angle of deviation of the line

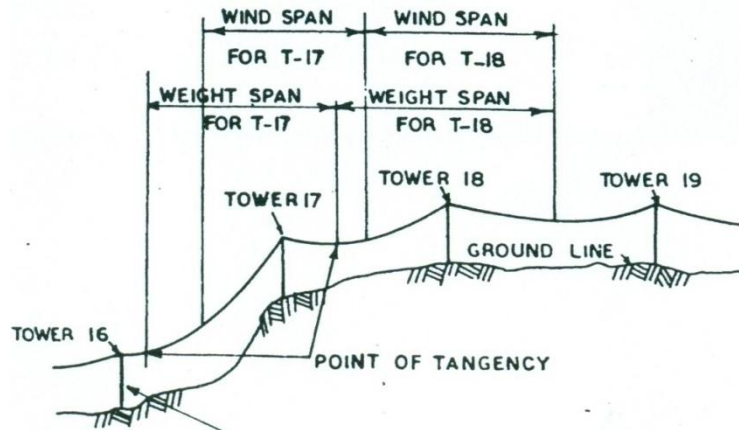

Fig. 1.11 Wind span and weight span (Murthy and Santhakumar 1990).

The wind span is the sum of the two half spans adjacent to the tower under considerations. The direction of wind on conductors is assumed to be parallel to the longitudinal axis of the cross arm.

The transverse load due to wind on the conductor /earth wire is given by the following equation:

$$F_{wc} = P * d * \text{Wind Span} \quad (1.5)$$

where

F_{wc} = transverse wind load on conductor/earth wire in N

P_d = wind pressure in N/m^2

d = diameter of conductor / earth wire in m.

Wind span is the distance between midpoints of two adjacent spans and as shown in Figure 1.11.

The wind load on the towers is usually converted into concentrated loads acting at the point of conductor and earth wire supports for convenience and testing. In addition, towers are subjected to wind loads acting on the exposed areas of the tower. The equivalent wind load at a point is added to the component loads get the total load at a support point. The wind load is assumed to be applied horizontally acting in the direction normal to the transmission line. The wind force coefficients on lattice towers depend on shapes of member sections, solidity ratio, angle of incidence of wind (face-on wind or diagonal wind), and shielding. Methods for calculating wind loads on transmission towers are followed as per IS:802 (Part 1 / Sec 1) :1995 RA

2006 and American Society of Civil Engineers (ASCE10-90: 1991) Design of latticed steel transmission structures.

Where a line changes direction, the total transverse load is the sum of the transverse wind load and the transverse component of the conductor/earth wire tension. The transverse component of the tension may be of significant magnitude, especially for large angle towers. To calculate the total load, a wind direction should be used which will give the maximum resultant load considering the effects on the conductor/earth wires and tower.

The transverse component of conductor /earth wire tension on the tower is given by the following equation:

$$F_{dt} = 2 * T * \sin \Theta / 2 \quad (1.6)$$

Where

F_{dt} = transverse load due to conductor/earth wire tension in N

T = conductor /earth wire tension in N

Θ = Line angle in degrees

1.3.1.2 Vertical loads

Vertical load is applied to the ends of the cross arms and on the earth wire peak and consists of the following components.

- a. Weight of conductor as specified over the governing weight span.
- b. Weight of insulators, hardware etc.
- c. Arbitrary load to provide for the weight of a man with tools during maintenance.

The vertical load on supporting towers consists of the weight of the tower and the superimposed weight of all conductors/earth wires.

Vertical load of conductor /earth wire V in N is given by the following equation:

$$V = Wt. \text{ of bare conductor/ earth wire (N/m)} * \text{Weight span (m)} \quad (1.7)$$

Where,

Weight span is the distance between low points of adjacent spans and is indicated in Figure 1.11. The weight span is generally assumed 1.5 times of wind span.

1.3.1.3 Longitudinal loads

Longitudinal loads may occur on the towers due to accidental events such as broken conductors, broken insulators or collapse of an adjacent tower in the line due to an environmental event such as a tornado (Figure 1.8b). Regardless of the triggering event, it is important that a tower to be designed for a suitable longitudinal loading condition to provide adequate resistance against cascading failures of larger number of towers sequentially in the line. For this reason, longitudinal loadings are sometimes referred to as “anti cascading”, “failure containment”, or “security loads”. There are two basic methods for reducing the risk of cascading failures one depending on the type of tower and the other on local conditions and practices. These methods are: (1) design all towers for broken wire loads and (2) install stop towers or guys at specified intervals. Certain types of towers such as square-based lattice towers, 4-guyed towers, and single shaft steel poles have inherent longitudinal strength. For lines using these types of towers, the recommended practice is to design every tower for one broken conductor load case. This provides the additional longitudinal strength for preventing cascading failures at a relatively low cost.

The longitudinal component of conductor /earth wire tension on the tower under broken wire condition is given by the following equation:

$$F_{d1} = T * \cos \Theta / 2 \quad (1.8)$$

Where

F_{d1} = longitudinal load due to conductor/earth wire tension in N

T = conductor /earth wire tension in N

Θ = Line angle in degrees

There are several other conditions under which a tower is subjected to longitudinal loading:

- (a). Dead end towers : These towers are capable of withstanding the full tension of the conductors and earth wires only on one side .
- (b). Stringing : Longitudinal load may occur at any one conductor or earth wire due to a hang-up in the blocks during stringing. The longitudinal load is taken as the

stringing tension for the complete conductor or an earth wire. In order to avoid any pre stressing of the conductors, stringing tension is typically limited to the minimum required to keep the conductor from touching the ground or any obstruction. Based on common practice and according to IEEE 524 “Guide to the Installation of Overhead Transmission Line Conductors”, stringing tension is generally about one-half of the sagging tension. Therefore, the longitudinal stringing load is equal to 50% of the initial, unloaded tension at 32 °C .

The loads acting on tower under normal and eventual operations are discussed above. The towers are designed for these loads with sufficient factor of safety.

1.4 RIGHT OF WAY (ROW) FOR A TRANSMISSION LINE AND THE ROLE OF TOWER

Right of way is the strip of land accommodating the transmission lines. Regulations demand that the width of this corridor to be maintained in order to keep the transmission line components at safe distances from the nearby structures and the components themselves. The tower which is the major component in the line determines the selection of this right of way. Right of way and the tower height together drive the cost of the line. ROW presents the land cost and the height of the tower presents the material cost. An approach which aims at reducing these two and in turn achieve economical cost is need of the hour. It is required to understand the details of the tower and associated clearances which help to reduce the cost.

The typical transmission line tower and its corridor are shown in Figure 1.12. It can be seen from the figure that the width of ROW consists of the clearances on either side of the base width of the tower. These clearances account for mandatory electrical clearance from the nearby structure and the swing of the insulator strings. Thus the right of way depends on the length of the insulator strings as these govern the swing width. The length of the insulator is determined based on transmitted voltage, long enough to provide electrical insulation between the conductors and body of the tower.

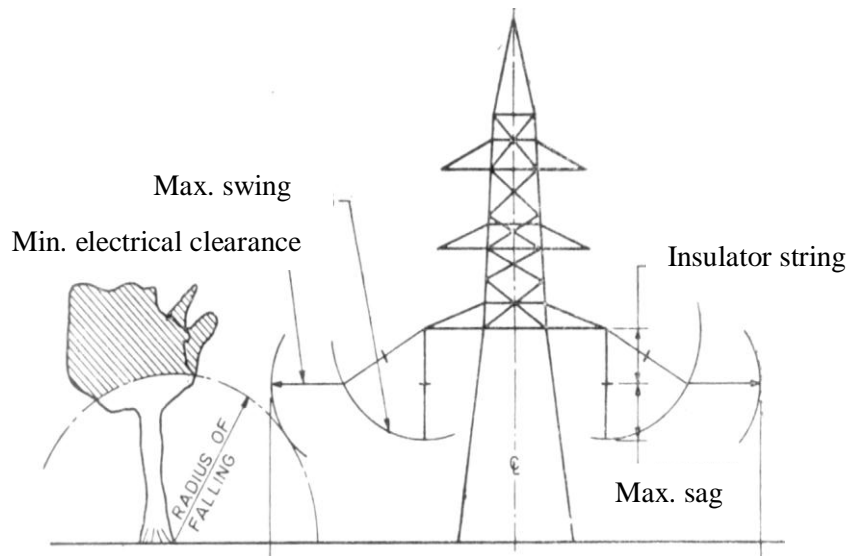

Fig. 1.12 Electrical clearance requirement (IS: 5613 Part 2 -1985)

In recent years, building new power transmission lines has been difficult on account of impediments in securing a Right of Way (ROW) access (Figure.1.12). In urban areas especially in developing countries like India, right-of-way space is highly expensive. Ghodrat Ollah Heidari et al. (2002) investigated the effect of land price on power transmission line design in urban areas. Nolasco. J.F and J.B.Da Silva (1992) have described the basic characteristics of right-of-way and the selection criteria for ROW (Mehrtash. A et al.(2007)).

Based on recommendations in standard, the right of way requirements and span range for different transmission lines is presented in Table 1.6.

Table. 1.6 Right of way requirement (IS:5613 Part 2 :1985)

Sl. No	System Voltage	ROW requirement	Span Range m
1.	33 kV AC	15m	90-135
2.	66 kV AC	18m	200-320
3.	110 kV AC	22m	305-335
4.	132 kV AC	27m	305-380
5.	220 kV AC	35m	320-380
6.	400 kV AC/ 500 kV HVDC	52m	400-450
7.	765 / 800 kV AC	85m	400-450

1.4.1 Need for reduction of ROW and tower height

Increasing difficulties in obtaining right of way for new power transmission lines, such as high price of land particularly in urban area, legal constraints on obtaining necessary permissions and limitations on availability of land, all together are driving the people to think about reduction of land needed for line corridor.

In order to reduce the space requirement of a transmission line tower both in horizontal and vertical directions, several types of structures are being developed and tested, at the same time keeping them less expensive (Kuhl.M 2001, Burnham.J.T and Grisham.T.M 1994). Further, improved and better materials are introduced as insulators and conductors to achieve still better power transmission lines (Dale Douglas and Jim Stewart 2010). Brain C Wood et al. 2006 proposed insulated cross arm to accommodate higher transmission voltages from 138 kV to 230 kV as a cost effective way to maximize utilization of the existing right-of-way. Jannat.H Aliour et. Al 2007 attempted to introduce the polymer insulation arms for decreasing the right of way. Kunikazu Izumi et al. 2000 developed line post type polymer insulation arm for

154 kV to reduce space requirement with minimized flashing of insulators particularly in coastal areas (Denis Dumora et al.1990)

Introduction of compact tower could be an attempt to reduce the dimensions of the tower, both in the horizontal and vertical directions. By reduction in horizontal direction, the right of way requirements are reduced. By reduction in vertical direction the height of the tower gets reduced, thus lowering cost also. Thus with a tower of composite materials, profile is reduced improving the visual and environmental impact. With these materials though visual impact and public acceptance are enhanced the cost is more.

1.4.2 Tower with composite members

The metallic towers can be seen everywhere from the suburbs to the crowded areas in downtown cities, distributing power to homes, apartments, hospitals, street lights, commercial buildings and factories etc. Due to terrestrial environment i.e., wind, rain and salty environment these metallic towers tend to corrode and get damaged. Presently used steel towers and ceramic insulators have better strength but do not provide necessary reduction in ROW and tower height.

The design of towers with composite materials could reduce phase to phase and phase to tower distances, which in turn help to increase the power transmitted with better insulation (James Slegers 2012, Miguel et al. 1998). It could be possible to build towers in transmission lines by composite materials to resolve the problems of ROW and tower height (Hsein-Yang 1997, Lawrence C. Bank 2006, Robert D. Castro 1995, Nihar Desai and Robert Yuan 2006, Camanho.P.P et al. 1997). Transmission line towers constructed from polymer composite sections using a "snap and build" assembly procedure eliminate fasteners and adhesives are attempted by Hsein-Yang 2010. Ebert Composite Corporation USA developed and installed three 230 kV double circuit composite transmission line towers in the year 2007 at Southern California Edison coastal facility (Walt Warner , 1997). These are performing exceptionally well in a highly corrosive coastal environment over a period of 15 years. Han-ming LI et al. 2010 introduced composite towers for 110 kV overhead transmission lines first time in China. The ASCE Manual No.104 also mentions the use of composites in overhead line towers (ASCE 2003).

Understanding the behaviour of these composite materials and assessing their suitability for tower applications needs intense focus of engineers and technologists.

The composite material is two or more materials combined in order to synergize their properties. Composite material is a heterogeneous mixture of two or more homogeneous phases which have been bonded together (Chawla 2001, Robert M.Jones 1999, Madhujit Mukhopadhyay. 2004). The combination is identified as a composite material if it has distinctive properties, compared to any of its constituent materials individually. Composite materials have carved themselves a niche as workable engineering materials in structural applications, especially, polymer matrix composites due to their light weight and non-corrosiveness. Fiber Reinforced Polymer matrix (FRP) composite materials are in use for structural applications since about 5 decades (Bakis. G.E et al.2002, Sedlacek.G et al 2005, Pizhong Qiao et al.2000).

Large number of research studies and structural engineering projects using FRP composite materials have been reported using thin-walled fiber reinforced polymer pultruded composite members (Hassan, N.K. Mosallam, A.S 2004, J.F.Davalos, et al. 1996, K.Liao et al. 1999, Barbero, E.J. et al. 1993, Aref, A.J. 1997, Acosta-Costa et al. 1999. Barbero, E.J 1993. Prabhakaran. R et al 1996, Polyzois, D. et al. 2000, Marisa Pecce et al. 2000, Mosallam et al. 1994, Sims, G.D et al. 1987, Bradford, N. M 2004, Banks and J.Rhodes 1980, John Tomblin and Ever Barbero. 1994, Kollár, L.P 2003, Thomas Keller (2004),). General truss structures and braced framed structures have been designed and constructed using thin-walled composite material pultruded members and have been working satisfactorily (Bakis.G.E 2002, Richard E.Chambers. 1997). Composites are yet to be exploited fully for rigorous structural applications like towers and this requires deeper understanding of material science and chemistry (Leonard Hollaway. 1995).

Design and development of transmission line towers with fiber reinforced composite materials is a plausible solution to overcome problems of corrosion, maintenance cost ROW access etc., and needs to be investigated critically. Also such an attempt could help to reduce the cost of towers due to smaller size, inherent electrical insulation due to material. Composites used in structural applications are thin, slender members experiencing axial forces.

Pultrusion is an economical process for fabricating composite members for tower applications. A brief description of pultrusion is given in the next section.

1.4.3 Pultrusion process for composite members

Pultrusion is a process suitable slender members having uniform cross section for use in structural engineering (Lawrence C. Bank 2006, Ravikant shrivastava et al. 2009, Gan, L.H et al. 1999). Pultrusion is continuous and highly cost-effective for producing structural shapes. Pultruded members consist of fiber reinforcements typically, glass or carbon and thermosetting resins typically polyester, vinylester and epoxy polymers. The fibers within pultruded members typically consist of longitudinal continuous fiber bundles, rovings or fiber mats. In pultrusion process, dry fibers are drawn through a low viscosity liquid thermosetting polymer resin and guided into heated chrome - plated steel die, where they are cured to form the desired shape. Figure 1.13 presents a schematic of the pultrusion process. Also Figure 1.14 shows the pultruded composite members with different cross sections.

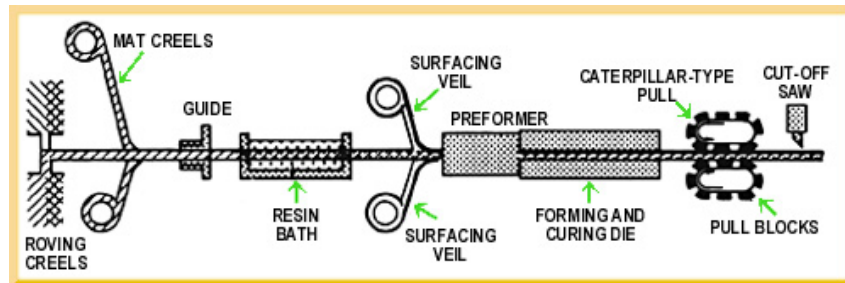

Fig. 1.13 Schematic of the pultrusion process

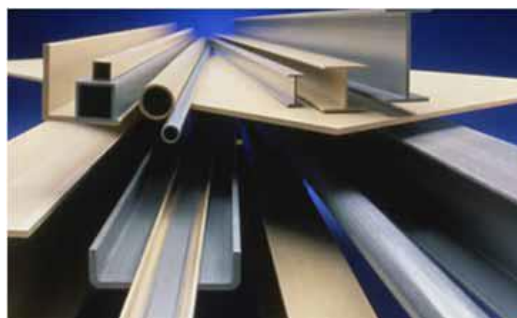

Fig. 1.14 Shapes of various members made with pultruded process

As realized from the description in the earlier sections introduction of pultruded composites for members of the tower helps us to achieve many benefits including reduction in ROW and tower height. The design of a tower with these composite members is complex owing to nature of these materials and nature of tower structure which is indeterminate. Thus multiple approaches required to design, analyze and test the towers with composite members which are derived from the approaches adopted from metallic towers.

1.5 DESIGN, ANALYSIS AND TESTING OF TOWER

As a preliminary step in design, loads on the tower are determined as explained in section 1.3. Based on these, a force analysis of the structure is undertaken to determine forces on each member. Size of each member is then determined from the force acting on the member computed above. Since tower structure is indeterminate, lot empirical guidelines and thumb rules are used to complete the design process. Thus the margins of safety are generally excessive.

The design guidelines are available in standards like IEC: 60826 and IS:800, 802... etc., to justify the final tower geometry and optimizing the tower design, analysis is to be carried out. Many computer assisted analysis tools are available presently for structural applications. These include dedicated user friendly software packages for quick and systematic analysis and also to optimize. Finite Element Method (FEM) has been widely used for analysis, especially in tower applications (F.G.A Albertmani et al. 2003, Sotiropoulos S.N. et al. 1994, Bansal.A et al, 1995). Availability of user-friendly software packages for FEA attracted engineers/scientists to use them for the composite applications also (Kulkarni 2002, El-Hajjar R.F 2004). The software provides facilities to create a model of entire structure, analyse and optimize before undertaking physical construction. A FEM software package MSC-NASTRAN (AFEA 2010.2.3) provides capability to model structures in the composite members and study the complex behavior under loading. This software has features for multiple loading scenarios under various environmental conditions and can model broad range of materials including metals, wood, plastics, rubbers, glass, concrete and composites. It provides the user to define element properties, geometries,

externally applied loads/deformations and the constraints on the nodal displacements. This software contains a second module, which formulates and solves the matrix equations for the component geometry defined in the first module. Finally a third module provides the facilities for mapping of stress/strain distributions in geometry. Also the nodal displacements may be plotted to see the deformed shape of the component.

The structural analysis software STAAD Pro-V8i is another one which has the capability of modeling full scale tower to simulate the field condition. This software has full range of features for structural analysis to model features of joints and members. It has extremely flexible structural modeling environment and provides broad spectrum of structural design codes.

As explained in the previous section a structure with geometry determined from the forces sustained by the members, could be analyzed using FEM virtually in a software package. The design is verified by ensuring maximum stress levels in the members to less than permissible values for materials.

Generally, the best verification of design is through prototyping and testing. The prototype testing establishes the validity of design in full spirit. Prototyping is an indispensable approach, when design paradigms are not fully available, and the design is based on semi-analytical and empirical guidelines. Prototyping also takes care of the artifacts which are not considered in design like backlash compliance and friction at joints. A design that is verified through the prototype testing definitely sustains the service conditions for longer duration and helps to incur economy in operation.

1.6 OBJECTIVE AND SCOPE OF THE PRESENT STUDY

From the foregoing literature survey, clear is the fact that the research reports on development of power transmission line tower members with composite is hardly available. This prompted a thorough and systematic study of the tower with composite members both analytically and physically with prototype testing. An attempt to replace the conventional members by composite members made of Glass – Epoxy (GE) is carried out. As pultrusion process provides the facility of manufacturing these composite members with various geometry, this is used as the process for fabrication of tower members. The pultruded GE members are chosen owing to good mechanical

strength and insulation. These composite members are used in construction of the cross arm and the tower.

Therefore following objectives are set for the work:

- Preparation of Glass Epoxy (GE) pultruded standard coupons and evaluation of their physical, mechanical, electrical and accelerated weathering / ageing properties.
- Designing tower members made of above materials for mechanical loads sustained by the tower determined from guidelines.
- Modeling and analysis of cross arm with composite members, tower sub assembly and full tower using FEA.
- Construction of cross arm from GE pultruded composite members and testing for the performance under mechanical and electrical loading.
- Construction of X-braced tower sub assembly with GE pultruded members of different cross sections and testing for mechanical loads and electrical insulation.
- Construction of full scale tower with GE pultruded members and testing for the performance under mechanical and electrical loads.

The scope of the present work includes,

- Design, analysis and testing of tower with composite members considered here is 66 kV double circuit, vertical, lattice type, narrow base, 200 m span, wind speed 47 m/s.
- Preparation and testing of GE coupons to characterize their mechanical, electrical properties for use as composite members in a tower.
- Design of the tower made of composite members from guidelines given in standards.
- FE Analysis of a cross arm, three tower units/sub-assemblies and a full tower with composite members using MSC-NASTRAN/ STAAD Pro software.
- Physical construction and testing of a cross arm, tower sub assembly with cross arm mounted and full tower for performance under mechanical and electrical loadings.

CHAPTER 2

2.0 MODELING

As introduced appropriately in chapter 1, the need for a compact transmission line to reduce ROW access could be achieved through introduction of towers with composite members. The design and analysis of tower generally precedes its construction and testing. The design of tower is generally as per the guidelines given in standard IS:802 (Part 1 / Sec 1) : 1995 RA 2006, as explained in chapter 1. With the advent of new tools for analysis like FEM modelling, verifying the designs has become simpler and economical. As outlined in the objectives and scope (section 1.6) of the work in the preceding chapter, selection of properties of GE pultruded members and the design of tower forms the initial part of the study and is described in this chapter. This chapter also focusses on structural/FE analysis of different components of a tower and ultimately a full tower using MSC-NASTRAN and STADD Pro softwares. It includes analysis of cross arm, X-braced tower units/sub assembly without and with cross arm, and finally the full towers. The configuration of tower proposed of composite members used for modelling and testing is discussed in the next section.

2.1 TOWER GEOMETRY BASED ON ELECTRICAL CLEARANCES AND OTHER CONSIDERATIONS

In the present Indian power systems, the policy adopted is to economize the cost of transmission lines constructed by developing compact transmission to reduce construction time and considerable savings of resources. Thus the tower made of composite members satisfies the above policies and is required to be analyzed thoroughly to achieve the compactness and in turn economy.

The configuration considered in present work is a narrow base vertical tower. It is a double circuit (D/C) tower with single earth wire peak. The geometry of the tower considered is shown in Figure 2.1. The various factors considered for arriving at these geometric attributes for 66 kV D/C line with 200 m span, wind speed 47 m/s are discussed below.

- a) Tower height from ground level.
- b) Length of the cross arms.
- c) Tower base width and bracing pattern adopted.

Both electrical and mechanical considerations are needed to determine above attributes.

2.1.1 Overall tower height (H)

The overall height of a tower (Figure 2.1) is determined from permissible ground clearance of power conductors required in accordance with regulations (h_1), the maximum sag for the lowermost conductors (h_2), vertical spacing of conductor supports (h_3) and height of the earth wire peak portion (h_4). Each of these is determined as below:-

Permissible ground clearance (h_1) is determined as per clause No.77 of the Indian Electricity Rule 1956 which stipulates the height above ground level as 5.50 m (h_1) for 66 kV lines. This is to ensure that conductors in the entire route of the transmission line are at a requisite height from the ground level. Maximum sag for the lowermost conductor (h_2) is required to be determined for calculating height of the tower. If the conductor is sagging extensively, the horizontal clearance are increased because conductor may swing due to resultant of horizontal wind force and vertical self weight. Size and type of conductor, wind, climatic condition of the region and span length determine the conductor sag. The maximum sag for conductor span occurs at the maximum temperature and still wind condition. The maximum sag is taken in to consideration in fixing the overall height of composite tower. Details of ACSR (Aluminum Conductor Steel Reinforced) power conductors conforming to IS:398 (Part-2):1996, RA 2002 and Galvanized steel earth wire conforming to IS:2141-2000 considered in the present work are listed in Table 2.1.

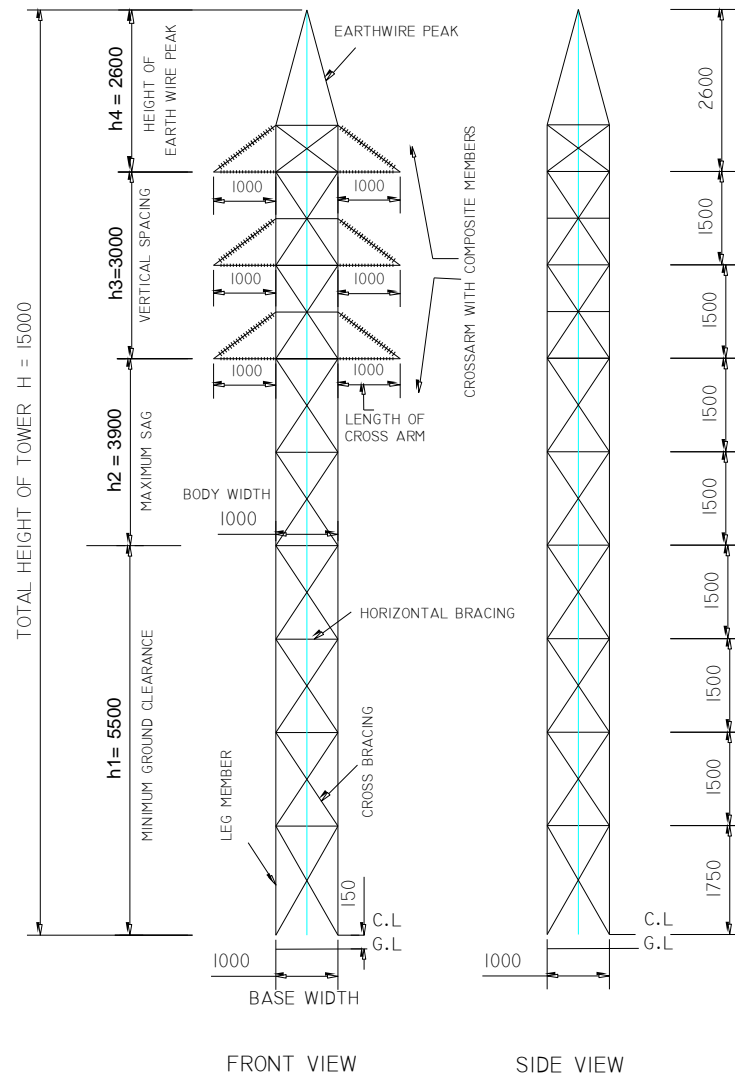

All dimensions are in mm

Fig. 2.1 Attributes of tower with composite members for 66 kV D/C line (IS: 5613 Part 2 -1985)

The proposed is designed tower with composite members to suit the maximum conductor temperature of 75°C generally followed for ACSR conductor (IS: 398 Part 2 -1996). The maximum temperature of earth wire exposed to sun is taken as 53°C (IS: 2141- 2000).

The sag and tension for conductor and earth wire are calculated in accordance with IS: 5613 (Part 2 / Sec 1): 1985 for the following wind and temperature combinations:

- a. 100 % design wind pressure at everyday temperature of 32⁰C.
- b. 36 % design wind pressure at minimum temperature of 0⁰ C.

Standard sag – tension equation considering the combined effect of elasticity and temperature are

$$\text{Maximum tension } T = f * A \quad (\text{CBIP Manual No.9}) \quad (2.1)$$

$$\text{Maximum sag } S = (q \delta l^2) / 8 T \quad (\text{CBIP Manual No.9}) \quad (2.2)$$

$$f^2 [f - (K - E \alpha t)] = \frac{l^2 \cdot \delta^2 \cdot E \cdot q^2}{24} \quad (\text{CBIP Manual No.9}) \quad (2.3)$$

In this equation various terms are defined below

f = Working tensile stress of conductor in kg/cm²

K = Constant computed from initial temperature and wind pressure conditions assumed.

E = Final modulus of elasticity in kg/cm²

α = Coefficient of linear expansion of conductor per degree C

t = Change of temperature (Final temperature - Initial temperature in degree C)

l = Span length in meters

δ = Weight of conductor /m/cm² = W/A kg/m / cm²

q = loading factor

$$= \text{SQRT} [(W^2 + P^2) / W^2] \quad (\text{CBIP Manual No.9}) \quad (2.4)$$

A = Cross sectional area of conductor in cm²

W = weight of conductor in kg/m length of conductor

P = wind load on conductor in kg/m length of conductor

Table 2.1 Properties of conductor and earth wire (IS: 398 and IS: 2141)

Description	ACSR Dog conductor	Earth wire
Stranding No. / diameter (mm)	Aluminum 6/4.72 + Steel 7/1.57	Steel 7/2.24
Overall Diameter (mm)	14.15	6.72
Total sectional area (mm ²)	118.5	27.6
Unit Weight (N/m)	3.94	2.3
Co-efficient of thermal expansion / °C	19.8 x 10 ⁻⁶	11.5 x 10 ⁻⁶
Modulus of elasticity (kg/cm ²)	7.74 x 10 ⁵	19.3 x 10 ⁵
Ultimate strength (N)	32422	17952

The sag and tension for conductor and earth wire are calculated using equation 2.1 to 2.3 and the results are presented in Table 2.2.

Table 2.2 Sag – Tension values calculated for conductor and earth wire under different temperature and wind conditions (IS: 5613 Part 2 -1985)
[Eqn. 2.1 - 2.3]

Condition	ACSR Dog conductor		Earth wire	
	Tension (N)	Sag (m)	Tension (N)	Sag (m)
75 ⁰ C / Nil wind	5229	3.69	---	---
53 ⁰ C / Nil wind	---	---	5150	2.19
32 ⁰ C / Nil wind	8143	2.38	5984	1.89
32 ⁰ C / 100 % wind	19767	5.00	12312	4.65
0 ⁰ C / Nil wind	11968	1.61	7465	1.45
0 ⁰ C / 36 % wind	14784	2.69	8976	2.57

Calculated sag increased by about 2 to 4 % (CBIP Manual No.9) of the maximum sag value to account for conductor creep and the profile correction.

It could be observed from the Table 2.2, the maximum sag of the conductor at maximum temperature of 75⁰ C is 3.69 m with additional 4 % to account for creep and the profile correction.

Maximum sag of the conductor (h_2) = 3.69 + 0.15 \approx 3.9 m

The vertical spacing (h_3) is governed by both electrical and mechanical requirements (Figure 2.2). The electrical requirement is governed by voltage surges, while the mechanical requirements are related to dynamic behavior of conductor due to tension, swing, sag, span etc. The vertical spacing between two cross arms (h_3) is determined (Figure 2.2) with the angle between main members and the inclined members of the cross arm to be 24° as below (CBIP Manual No.9).

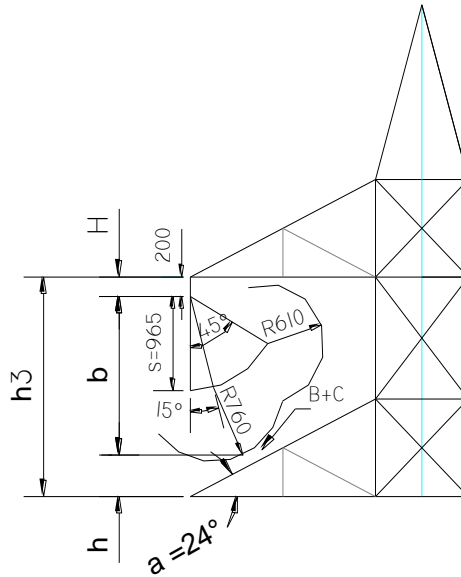

Fig 2.2 Vertical spacing between cross arms

The minimum vertical spacing between two cross arms (h_3) equals $H + b + h$ where

$$H = (X_2 + B+C) - S \cos \theta_2 \quad (2.5)$$

$$\left. \begin{array}{l} \text{OR} \\ (X_1 + B+C) - S \cos \theta_1 \end{array} \right\} \text{(CBIP Manual No.9)} \quad (2.6)$$

Generally higher of the above may be adopted.

$$b = (S + X_1 + B+C) \cos \alpha \quad (2.7)$$

$$\left. \begin{array}{l} h = a \cdot \tan \alpha \\ \text{Where } a = (S + X_1 + B+C) \sin \alpha \end{array} \right\} \text{(CBIP Manual No.9)} \quad (2.8)$$

H = Height of hanger

α = Angle between inclined member of cross arm and lower main member of the cross arm (24°)

S = Length of suspension string (965 mm)

θ_1 = Minimum swing angle of the suspension string (15°)

θ_2 = Maximum swing angle of the suspension string (45°)

X_1 = Electrical clearance corresponding to swing angle θ_1 (760 mm)

X_2 = Electrical clearance corresponding to swing angle θ_2 (610 mm)

B = Flange width of the nearest projecting angle sections connected to main angle members

C = Distance of centre of gravity of the main angle sections from the heel of angle member

B+ C = constant (150 mm generally assumed)

IS:5613

By substituting the values in the equations 2.5 to 2.8, the vertical spacing between two steel cross arms (h_3) with insulator string is calculated to be about 2.25 m. For the proposed cross arm with composite members it is 1.5 m (h_3) because insulator string is not required in this case.

The spacing required between the earth wire and top power conductor (h_4) at mid span is to ensure that a lightning stroke hitting the earth wire does not flashover to power conductor. From the lightning protection point of view, the earth wire is hung with 10 -15 % lesser sag than the power conductor so as to give larger mid span spacing, generally at least 10 % under all temperature conditions in still wind at the normal spans in order to maintain minimum mid span clearance of 3.0 m for 66 kV lines. The location of earth wire is governed by the angle of shielding (Figure 2.3) i.e., the angle which the line joining the earth wire and the outermost conductor makes with the vertical.

30° angle of shield is considered for 66 kV as per IS: 5613 Part 2 -1985. Thus the height of earth wire peak (h_4) is determined as 2.6 m for tower with composite members which satisfies lightning protection.

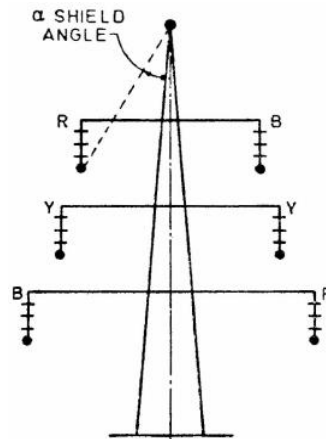

Fig. 2.3 Location of earth wire with shielding angle

Hence, the overall height of tower with composite members

$$\begin{aligned}
 H &= h_1 + h_2 + h_3 + h_4 & (2.9) \\
 &= 5.50 + 3.90 + 1.50 + 1.50 + 2.60 \\
 &= 15 \text{ m}
 \end{aligned}$$

2.1.2 Length of cross arm with composite members

Unlike in conventional towers, the power conductors are attached directly at the tip of the cross arm without insulator strings. As the members of cross arm being made of polymer composite material they provide the required insulation. Hence the length of cross arm determined based on the safe electrical clearances is shorter as explained below. The length of the cross arm is considered from the center line of the power conductor to the centre of gravity of the nearest main leg members of cross arm (Figure 2.1).

$$\text{Length of the cross arm } L_1 = S \sin \theta_1 + X_1 + B+C \quad (2.10)$$

OR

$$L_2 = S \sin \theta_2 + X_2 + B+C \quad (2.11)$$

(CBIP Manual No.9)

$$\begin{array}{l}
S = \text{Length of suspension string (965 mm)} \\
\varnothing_1 = \text{Minimum swing angle of the suspension string (15}^\circ\text{)} \\
\varnothing_2 = \text{Maximum swing angle of the suspension string (45}^\circ\text{)} \\
X_1 = \text{Electrical clearance corresponding to swing angle } \varnothing_1 \text{ (760 mm)} \\
X_2 = \text{Electrical clearance corresponding to swing angle } \varnothing_2 \text{ (610 mm)} \\
B + C = \text{constant (150 mm generally assumed)}
\end{array}
\left. \vphantom{\begin{array}{l} S \\ \varnothing_1 \\ \varnothing_2 \\ X_1 \\ X_2 \\ B+C \end{array}} \right\} \text{IS: 5613}$$

Since there are no swinging of insulator strings and the conductor is attached to the tip of cross arm itself the first term in equations 2.10 and 2.11 are zero. Substituting other values mentioned above in bracket.

$$\begin{aligned}
L_1 &= 0 + 760 + 150 \\
&= 910 \text{ mm}
\end{aligned}$$

$$\begin{aligned}
L_2 &= 0 + 610 + 150 \\
&= 760 \text{ mm}
\end{aligned}$$

The greater of the above two values i.e., 910 mm is rounded off to 1000 mm as length of cross arm and is considered in the present work. This is lesser than the length of cross arm for conventional tower due to the absence of suspended insulator strings which are prone to swing.

% reduction in length of cross arm with composite members is

$$\begin{aligned}
&= [(1500 - 1000) / 1500] * 100 \\
&= 33 \%
\end{aligned}$$

A reduction of about 33 % is achieved in the total length of the cross arm.

2.1.3 Tower base width and bracing pattern

The spacing between the tower footings, i.e the base width at the concrete level (or at the foot of bottom panel) is the distance from the centre of gravity of one corner leg member to the centre of gravity of the adjacent corner leg member (Figure 2.1). The base width of tower depends on moments of physical loads imposed upon the tower and is generally determined based on size, type of conductors, wind loads and the heights of loads from ground level.

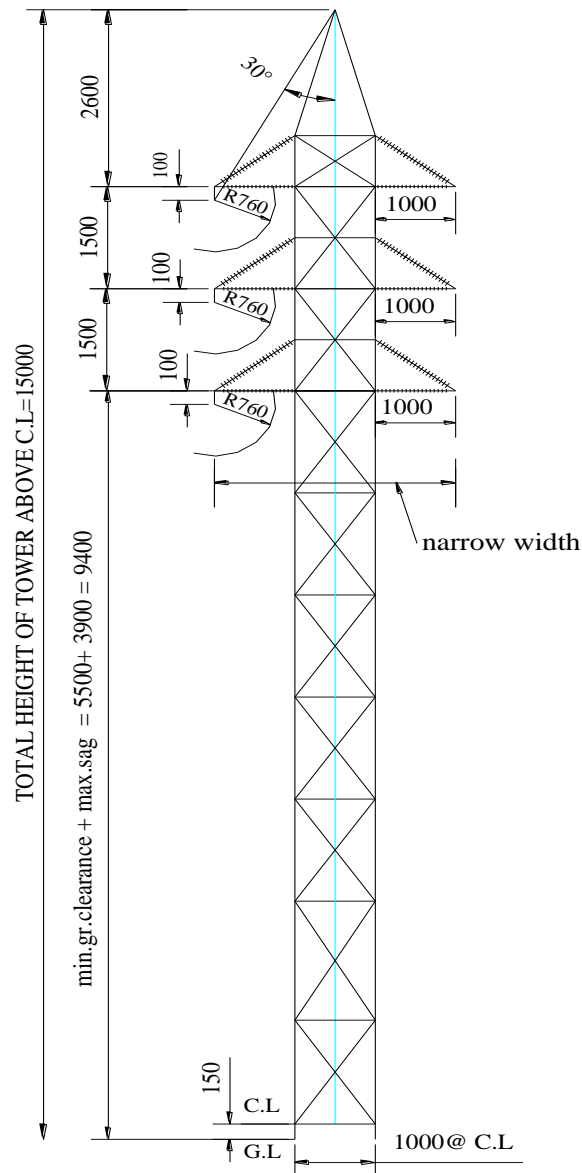

Fig. 2.4 Tower with composite members for 66 kV D/C compared with a conventional tower

For the present work narrow base width of 1.0 m x 1.0 m square type has been considered, recommended as requirement of 66 kV lines. The tower with composite members of a 66 kV D/C tower suitable for wind span of 200 m is shown in Figure 2.4. The bracing pattern adopted for the tower with composite member is double web or warren system (Figure 2.4) made up of diagonal cross bracings. The diagonal braces are fastened at their crossover points. Diagonal bracings provide for tension and compressive loads. The diagonal bracing with tensile stress gives an effective support to the other with compressive stress at the point of their connection and thus

the unsupported length of bracing is reduced which results in shorter bracing members.

2.2 DETERMINATION OF LOADS ON THE TOWER

As explained earlier in chapter 1, transmission lines are subjected to various loads during their lifetime. These loads are classified into three distinct categories, namely

- a. Climatic/wind loads – related to reliability requirements.
- b. Failure containment loads – related to security requirements.
- c. Construction and maintenance loads – related to safety requirements.

These loads on a tower act in three mutually perpendicular directions i.e., vertical (acting downwards), transverse (perpendicular to line) and longitudinal loads (parallel to line).

2.2.1 Transverse load

The transverse load due to wind on the conductor /earth wire is determined using equation 1.5 and 1.6. The details of transverse load calculation are presented in Table 2. 2. In order to determine the wind load on the tower with composite members, the tower is divided into different panels having a height ‘h’ between the intersections of the legs and bracings (Figure 2.5). For the proposed tower of square cross section, the resultant wind load F_{wt} for wind normal to the longitudinal face of tower, on a panel of height ‘h’ acting at the centre of gravity of the panel is

$$F_{wt} = P_d \times C_{dt} \times A_e \times G_T \quad (2.12)$$

Where

P_d = design wind pressure N/m^2

C_{dt} = drag coefficient

A_e = total net surface area of the legs, bracings, cross arms and secondary members of the panel projected normal to the face in m^2

G_T = gust response factor peculiar to the ground roughness and depends on the height above ground.

The wind loads on towers are usually assumed as concentrated loads acting at the point of conductor and earth wire supports acting in a direction normal to the transmission lines in horizontal plane for convenience of calculation (Figure 2.4) .

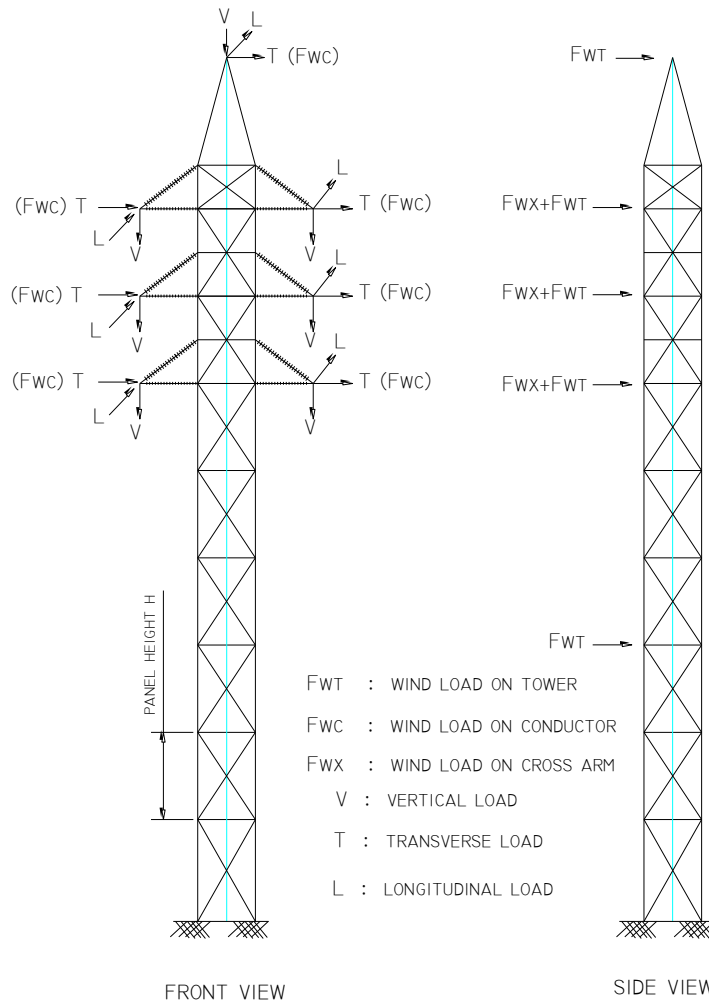

Fig 2.5 External loads and wind loads acting on tower with composite members

The load due to wind on each conductor and earth wire F_{wc} acting at supporting point normal to the transmission line is determined by the following expression:

$$F_{wc} = P_d \times C_{dc} \times L \times d \times G_c \quad (2.13)$$

Where

P_d = design wind pressure N/m^2

C_{dt} = drag coefficient taken as 1.0 for conductor and 1.2 for earth wire

L = wind span, being sum of half the span on either side of supporting point in m

d = diameter of conductor / earth wire in m

G_c = gust response factor, taken into account the turbulence of the wind and the dynamic response of the conductor.

Wind load on cross arm with composite members F_{wx} is determined from the exposed area of cross arm.

$$F_{wx} = P_d \times C_{dt} \times A_x \times G_x \quad (2.14)$$

Where

P_d = design wind pressure N/m^2

C_{dt} = drag coefficient taken as 1.2

A_x = Exposed area of cross arm

G_x = gust response factor

2.2.2 Vertical loads

The loads due to weight of each conductor and earth wire are based on appropriate weight span, weight of accessories etc. These are estimated using equation 1.7 for reliability, security and safety loading conditions. As suggested in the standard IS: 802, the vertical loads under safety condition are to be multiplied by a over load factor of 2.0 to account for operation and maintenance of a transmission lines. The detailed vertical load calculations are presented in Table 2.3.

2.2.3 Longitudinal loads

The longitudinal loads for suspension towers as suggested in standard IS:802 is taken as nil under reliability condition. 50 % of tension in the conductor and 100 % tension in earth wire are to be considered for longitudinal loads under security condition. The details of longitudinal loads calculations are provided in Table 2.2.

Table 2.3a Loads under reliability conditions

ACSR Dog conductor

I) TRANSVERSE LOAD :

1)	Wind on conductor	$P_d \times 1.1L \times d_1 \times C_{dc} \times G_c$	P_d 71.5	L 200	d₁ 0.0142	C_{dc} 1.00	G_c 1.94	433
2)	Due to deviation	$2T_1 \times \sin(\alpha/2)$	2 2.0	T₁ 2015	Sin(α/2) 0.0175			71

TOTAL **504**

II) VERTICAL LOAD :

1)	Maximum vertical load	$1.5L \times W_1$	1.5 1.5	L 200	W₁ 0.394			118
2)	Weight of composite cross arm							20

TOTAL **138**

III) LONGITUDINAL LOAD:

	Longitudinal load							NIL
--	-------------------	--	--	--	--	--	--	-----

Earth wire

I) TRANSVERSE LOAD :

1)	Wind on earth wire	$P_d \times 1.1L \times d_2 \times C_{dc} \times G_c$	P_d 71.5	L 200	d₂ 0.00672	C_{dc} 1.20	G_c 1.95	247
2)	Deviation load	$2T_2 \times \sin(\alpha/2)$	2 2.0	T₂ 1255	Sin(α/2) 0.0175			44

TOTAL **291**

II) VERTICAL LOAD :

1)	Maximum vertical load	$1.5L \times W_2$	1.5 1.50	L 200	W₂ 0.230			69
2)	Weight of attachments							10

TOTAL **79**

III) LONGITUDINAL LOAD:

	Longitudinal load							NIL
--	-------------------	--	--	--	--	--	--	-----

All loads are in kg

P_d = Wind pressure kg/m²

L = Span in m

T_1 = Tension in conductor in kg

T_2 = Tension in earth wire in kg

α = Angle of deviation

C_{dc} = Drag co-efficient

G_c = Gust response factor

W_1 = Unit weight of conductor kg/m

W_2 = Unit weight of earth wire kg/m

$d_1 d_2$ = diameter of conductor/earth wire in m

Table 2.3b Loads under security conditions

ACSR Dog conductor

I) TRANSVERSE LOAD :

1)	Wind on conductor	$0.75 \times Pd \times 1.1L \times d_1 \times C_{dc} \times G_c$	Pd 71.5	L 200	d₁ 0.0142	C_{dc} 1.00	G_c 1.94	324
2)	Due to deviation	$2T_1 \times \sin(\alpha/2)$	2 2.0	T₁ 1710	Sin($\alpha/2$) 0.0175			60

TOTAL **384**

II) VERTICAL LOAD :

1)	Maximum vertical load	$1.5L \times W_1$	1.5 1.50	L 200	W₁ 0.394			118
2)	Weight of composite cross arm							20

TOTAL **138**

III) LONGITUDINAL LOAD:

	Longitudinal load							NIL
--	-------------------	--	--	--	--	--	--	-----

Earth wire

I) TRANSVERSE LOAD :

1)	Wind on earth wire	$0.75Pd \times 1.1L \times d_2 \times C_{dc} \times G_c$	Pd 71.5	L 200	d₂ 0.00672	C_{dc} 1.20	G_c 1.95	186
2)	Deviation load	$2T_2 \times \sin(\alpha/2)$	2 2.0	T₂ 1255	Sin($\alpha/2$) 0.0175			38

TOTAL **224**

II) VERTICAL LOAD :

1)	Maximum vertical load	$1.5L \times W_1$	1.5 1.5	L 200	W₂ 0.230			69
2)	Weight of attachments							10

TOTAL **79**

III) LONGITUDINAL LOAD:

	Longitudinal load							NIL
--	-------------------	--	--	--	--	--	--	-----

All loads are in kg

- P_d = Wind pressure kg/m^2
- L = Span in m
- T_1 = Tension in conductor in kg
- T_2 = Tension in earth wire in kg
- α = Angle of deviation
- C_{dc} = Drag co-efficient
- G_c = Gust response factor
- W_1 = Unit weight of conductor kg/m
- W_2 = Unit weight of earth wire kg/m
- d_1 d_2 = diameter of conductor/earth wire in m

Table 2.3c Loads under safety conditions

ACSR Dog conductor							
I) TRANSVERSE LOAD :							
1)	Wind on conductor	$P_d \times 1.1L \times d_1 \times C_{dc} \times G_c$	P_d 0.00	L 200	d_1 0.0142	$C_{dc} \quad G_c$ 1.00 1.94	00
2)	Due to deviation	$2T_1 \times \sin(\alpha/2)$	2 2.0	T_1 830	$\sin(\alpha/2)$ 0.0175		29
TOTAL							29
II) VERTICAL LOAD :							
1)	Maximum vertical load	$(1.5L \times W_1) \times 2$	1.5 1.50	L 200	W_1 0.394		236
2)	Weight of composite cross arm						20
3)	Weight of lineman with tool kit						153
4)	Additional load on tip of cross arm						357
TOTAL							766
III) LONGITUDINAL LOAD:							
	Longitudinal load						1020
Earth wire							
I) TRANSVERSE LOAD :							
1)	Wind on earth wire	$P_d \times 1.1L \times d_2 \times C_{dc} \times G_c$	P_d 0.00	L 200	d_2 0.00672	$C_{dc} \quad G_c$ 1.20 1.95	00
2)	Deviation load	$2T_2 \times \sin(\alpha/2)$	2 2.0	T_2 1255	$\sin(\alpha/2)$ 0.0175		44
TOTAL							44
II) VERTICAL LOAD :							
1)	Maximum vertical load	$1.5L \times W_2$	1.5 1.50	L 200	W_2 0.230		138
2)	Weight of attachments						20
3)	Weight of Line man with tool kit						153
TOTAL							311
III) LONGITUDINAL LOAD:							
	Longitudinal load						NIL

All loads are in kg

P_d = Wind pressure kg/m² C_{dc} = Drag co-efficient
 L = Span in m G_c = Gust response factor
 T_1 = Tension in conductor in kg W_1 = Unit weight of conductor kg/m
 T_2 = Tension in earth wire in kg W_2 = Unit weight of earth wire kg/m
 α = Angle of deviation $d_1 \quad d_2$ = diameter of conductor/earth wire in m

Table. 2.3d Summary of calculated loads as per IS:802 Part 1/Sec 1- 1995 for a 66 kV tower

Wind zone – 4	Design loads (N)					
	Reliability condition			Security Condition		
	V	T	L	V	T	L
Wind span 200 m	1375 (785)	4955 (2895)	0 (0)	935 (540)	2210 (1275)	8390 (10645)
ACSR Dog conductor	Safety – Normal condition					
	V : 7555 (3090)		T : 295 (245)		L : 0 (0)	

V- Vertical, T- Transverse, L- Longitudinal,
 Values in brackets indicated loads on earth wire

The above loads are calculated as per IS: 802 (Part-1/Sec-1): 1995 are presented in Table 2.3 corresponding loading trees in Figure 2.6. These loads are considered for design / analysis of cross arm, X – braced tower units/sub-assemblies and full scale tower with composite members.

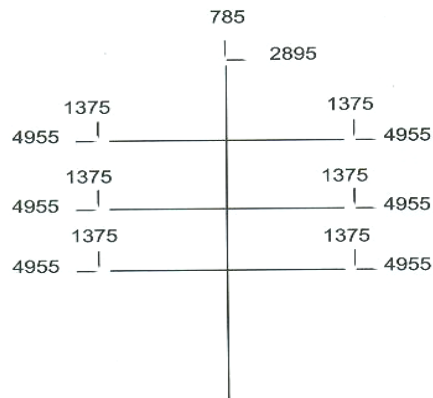

1. Reliability condition
(No longitudinal load)

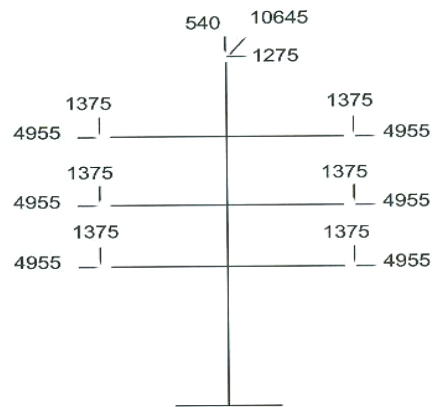

2a. Security condition – Earth wire broken

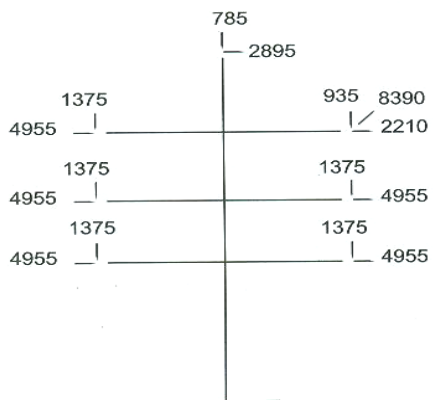

2b. Security condition – Top conductor broken

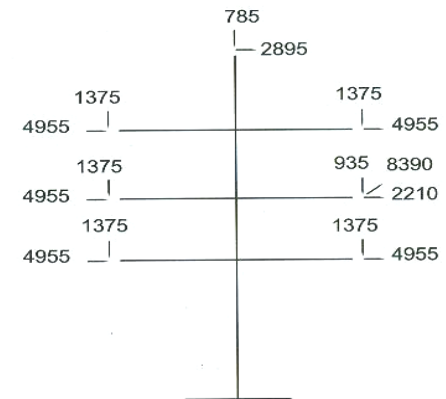

2c. Security condition – Middle conductor broken

Fig. 2.6a Loading trees for wind zone 4 (200 m)

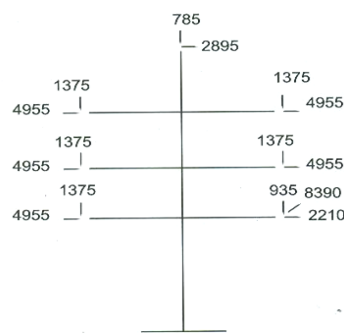

2d. Security condition – Bottom conductor broken

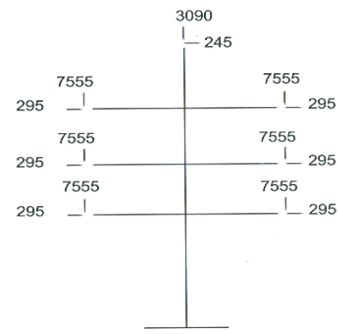

3. Safety condition
(No longitudinal load)

Fig. 2.6b Loading trees for wind zone 4 (200 m)

2.3 Design of GE pultruded members for tower

Generally the tower members are subjected to axial loads either in tension or compression. Due to its slenderness, the members are weak under compressive loads. The theoretical compressive strength is determined for GE pultruded members using Euler's equation. The Euler buckling equation accurately predicts the critical buckling load for slender columns in terms of the bending stiffness (EI), the column length L , and the end-restraint coefficient k .

The critical buckling load for a homogeneous member, including the effects of shear deformation, is given as (Lawrence C. Bank 2006)

$$P_{cr}^{flex} = \frac{P_{euler}}{1 + P_{euler} / k_{tim} A_z G_{LT}} \quad (2.15)$$

$$P_{euler} = \frac{\pi^2 E I}{(kL)^2} \quad (2.16)$$

P_{euler} = Euler buckling load ,

E = Compressive longitudinal modulus of the pultruded section

I = Second moment of area about minor axis of the profile

k = End-restraint coefficient

The critical buckling stress, including the effects of shear deformation is given as

$$\sigma_{cr} = \frac{\pi^2 E_L}{(kL/r)_{max}^2} \left[\frac{1}{1 + (1/k_{tim} G_{LT}) (\pi^2 E_L / (kL/r)_{max}^2)} \right] \quad (2.17)$$

Where $(kL/r)_{max}$ is the maximum slenderness ratio of the element, k_{tim} is the Timoshenko shear coefficient and A_z is the cross sectional area. For the present work the effects of shear deformation is neglected (Lawrence C.Bank 2006). Hence, the term in the brackets in equation (2.16) is set to unity.

$$\text{Allowable compressive stress } \sigma_{ac} = \sigma_{cr} / \text{FOS} \quad (2.18)$$

FOS = Factor of Safety

The theoretical compressive strength of a GE pultruded members used to build the X-braced tower units / sub assembly and full scale tower is worked out for different slenderness ratio (L/r). The details are shown in Table. 2.4

Table 2.4 a) Compressive strength and ultimate loads for different GE pultruded members

Section mm	Area mm ²	E N/mm ²	r mm	L mm	kL/r	σ_{cr} N/mm ²	P_{cr} kN
Ø 33	856	55000	8.25	500	60.61	147.9	126.55
Cross arm members				750	90.91	65.7	56.25
				1000	121.21	36.9	31.58
				1250	151.52	23.6	20.24
50x50x6	564	55000	15.26	500	32.28	505.73	285.23
Diagonal bracing				750	49.16	224.77	126.77
				1000	65.55	126.43	71.31
				1250	81.94	80.92	45.64
				1500	98.33	56.19	31.69
				1750	114.71	41.28	23.28
				2000	131.10	31.61	17.83

Table 2.4 b) Compressive strength and ultimate loads for different GE pultruded members

Section mm	Area mm ²	E N/mm ²		r mm	L mm	kL/r	σ_{cr} N/mm ²	P _{cr} kN
76.2x76.2x6.35		916	55000	24	500	21.03	1228.43	1125.4
Tower peak members					750	31.54	545.97	500.18
					1000	42.06	307.11	281.35
					1250	52.57	196.55	180.06
					1500	63.09	136.49	125.04
					1750	73.60	100.28	91.86
					2000	84.12	76.78	70.37
101.6 x101.6 x 6.35		2413	55000	38.13	500	13.11	3159.89	7624.49
Leg members – hollow section					750	19.67	1404.39	3388.66
					1000	26.22	789.97	1906.12
					1250	32.78	505.58	1219.92
					1500	39.34	351.10	847.16
101.6 x101.6 x 9.525		3536	55000	37.6	500	13.30	3072.17	10861.6
Leg members – hollow section					750	19.95	1365.41	4827.38
					1000	26.60	768.04	2715.40
					1250	33.24	491.55	1737.85
					1500	39.89	341.35	1206.84
70x20	1400	55000	20.21	500	24.74	887.33	1242.2	
Leg members – solid section					750	37.12	394.37	552.12
					1000	49.49	221.83	310.56
					1250	61.86	141.97	198.76
					1500	74.23	98.59	138.03

It could be observed from the Table 2.4, the ultimate load of hollow sections are higher than the solid section, hence, it is selected for leg members and solid circular section used for cross arm members and angle sections are selected for bracing and tower peak members.

2.4 Design of cross arm with composite members

The schematic arrangement of cross arm with composite members attached to tower body is shown in Figure 2.7. The loads are considered for design of cross arm as per loading trees (Figure 2.6). For the purpose of design, GE pultruded members of cross arm are taken to be linear elastic and brittle. Design is performed using equations based on basic structural mechanics. The criterion adopted for design is that the safety of a structure i.e. no structural member reaches its ultimate strength under nominal service loads.

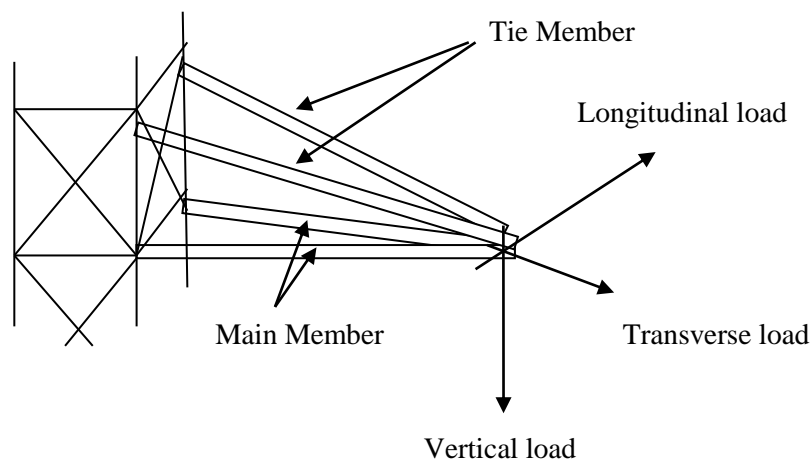

Fig 2.7 Schematic arrangement of cross arm attached to the tower body

The axial forces in the members of cross arm are obtained using method of sections as below:

Forces in the main members of cross arm due to transverse and vertical loads

$$F_1 = T/2 \cos \gamma/2 + V \cot \beta \quad (\text{CBIP Manual No.9}) \quad (2.19)$$

Where T is the Transverse load per face, γ is the angle included between the two main members of cross arm in horizontal plane

V is the Vertical load per face, β is angle included between the tie and main members of cross arm in vertical plane

Forces in the tie members of composite cross arm due to the vertical load

$$F_2 = V / \sin \beta \quad (\text{CBIP Manual No.9}) \quad (2.20)$$

Forces in the main members of composite cross arm due to longitudinal load

$$F_3 = L/2 \sin \gamma/2 \quad (\text{CBIP Manual No.9}) \quad (2.21)$$

Where L is the longitudinal load at the end of composite cross arm.

Maximum forces in the members of cross arm due to

external loads $F = 11290 \text{ N}$

$$\text{Ultimate load (buckling) of the member } P = (2*\pi^2 E I) / L^2 \quad (2.22)$$

$$I = (\pi *d^4) / 64 \quad (2.23)$$

Modulus $E = 50 \text{ GPa}$

Length of cross arm member $L = 1000 \text{ mm}$

By substituting these values to equation 2.22 and 2.23, the required diameter of the cross arm members comes to be 22 mm. Thus a standard diameter of 33 mm is adopted for the members of the cross arm.

2.5 Design of full tower with composite members

The full scale tower with composite GE pultruded members is shown in Figure 2.8. The tower consists of members whose details are furnished in Table 2.5. This tower is modeled using STAAD Pro software. The tower is modeled with 59 nodes and 246 elements/members with bottom four nodes completely restrained all degrees of freedom to simulate the fixed support. All the loads and boundary conditions on the tower are applied to simulate the service condition of the tower.

Table 2.5 GE pultruded sections selected for full scale tower

Description	Section size (mm)
Leg member - square hollow section	101.6x101.6x6.35 / 101.6x101.6x9.535
Bracing - equal angle section	50x50x6 / 76.2x76.2x6.35
Horizontal - equal angle section	50x50x6
Cross arm - solid circular rod	Ø 33

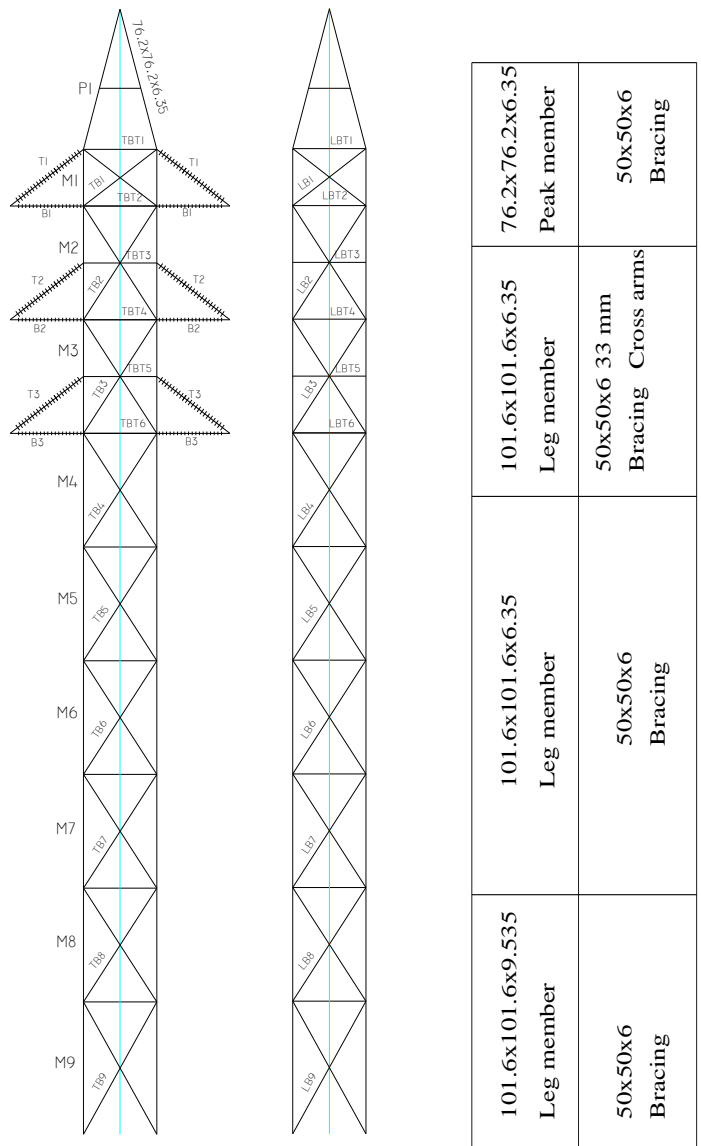

Fig. 2.8 Geometric model of full tower and GE pultruded members selected.

The member forces are obtained from the STAAD Pro software. These members are designed for either compression or tension. The load carrying capacity of the members are carried out IS: 802 (Part 1/ Sec 2) : 1995 RA 2003 standard which lay down the permissible slenderness ratio and appropriate length to be taken for working out the allowable compressive stress (Table 2.6).

Table 2.6a Member design chart for full scale tower

Member code	DESIGN INPUT				COMPRESSION DESIGN						TENSION DESIGN				BOLTS DESIGN										
	Max Comp. Fc	LC No.	Max Tension Ft	LC No.	Pultruded Section Selected		Effective length	Radius of gyration r	Gross Area	K/r	Allowable stress σc	Member capacity, Mr	FOS	Net Area	Allowable stress σt	Member capacity, Mr	FOS	Bolt Dia	Bolt Gr.	shear stress σs	bearing stress σb	No. of Bolts			
					mm	X mm																	X mm	X mm	N/mm ²
PI	11989.6	2	11655.8	2	76.2	X	76.2	X	6.35	990	14.73	916.13	67.2	109	99855	8.3	595.5	400	238200	20	12	8.8	496	1200	2
M1	14308.5	2	12450.5	2	101.6	X	101.6	X	6.35	1500	38.86	2413	38.6	331	410109	28.7	1448	400	579200	47	12	8.8	496	1200	4
TBT1	1883.13	2	3799	2	50	X	50	X	6	1000	9.60	568	104.2	45	25560	13.6	341	400	136400	36	12	8.8	496	1200	2
LBT1	1254.3	1	414.47	2	50	X	50	X	6	1000	9.60	568	104.2	45	25560	20.4	341	400	136400	329	12	8.8	496	1200	2
TB1	2275.82	3	945.78	3	50	X	50	X	6	625	9.60	568	65.1	116	66138	29.1	341	400	136400	144	12	8.8	496	1200	2
LB1	3311.5	2	3234.3	2	50	X	50	X	6	625	9.60	568	65.1	116	66138	20.0	341	400	136400	42	12	8.8	496	1200	2
TBT2	2050.19	3		3	50	X	50	X	6	1000	9.60	568	104.2	45	25560	12.5	341	400	136400		12	8.8	496	1200	2
LBT2		1	945.78	2	50	X	50	X	6	1000	9.60	568	104.2	45	25560		341	400	136400	144	12	8.8	496	1200	2
M2	22874.46	3	19855	3	101.6	X	101.6	X	6.35	1500	38.86	2412.9	38.6	331	410109	17.9	1448	400	579200	29	12	8.8	496	1200	4
TBT3		3	1773.45	3	50	X	50	X	6	1000	9.60	568	104.2	45	25560		341	400	136400	77	12	8.8	496	1200	2
LBT3	639.9	1		2	50	X	50	X	6	1000	9.60	568	104.2	45	25560	39.9	341	400	136400		12	8.8	496	1200	2
TB2	4868.5	3	5823.6	3	50	X	50	X	6	625	9.60	568	65.1	116	66138	13.6	341	400	136400	23	12	8.8	496	1200	2
LB2	2771.7	3	7242.2	3	50	X	50	X	6	625	9.60	568	65.1	116	66138	23.9	341	400	136400	19	12	8.8	496	1200	2
TBT4	3185.3	2		4	50	X	50	X	6	1000	9.60	568	104.2	45	25560	8.0	341	400	136400		12	8.8	496	1200	2
LBT4	885.54	1	1876.8	4	50	X	50	X	6	1000	9.60	568	104.2	45	25560	28.9	341	400	136400	73		8.8	496	1200	2

Table 2.6b Member design chart for full scale tower

DESIGN INPUT										COMPRESSION DESIGN										TENSION DESIGN						BOLTS DESIGN					
Member code	Max Comp. Fc N	LC No.	Max Tension Ft N	LC No.	LC Pultruded Section No. Selected	mm	X	mm	X	mm	Effective length mm	Radius of gyration r mm	Gross Area mm ²	K/r	Allowable stress σc N/mm ²	Member capacity, Mc N	FOS Mc/Fc	Net Area mm ²	Allowable stress σt N/mm ²	Member capacity, Mt N	FOS Mt/Ft	Bolt Dia mm	Bolt Gr	shear stress σs N/mm ²	bearing stress σb N/mm ²	No. of Bolts					
																											3	4	2	4	3
M3	39350.16	3	34885.14	3	101.6	X	101.6	X	6.35	1500	38.86	2412.9	38.6	331	410109	10.4	1448	400	579200	17	12	8.8	496	1200	6						
TBT5		4	1805.63	2	50	X	50	X	6	1000	9.60	568	104.2	45	25560		341	400	136400	76	12	8.8	496	1200	2						
LBT5	815.4	2		2	50	X	50	X	6	1000	9.60	568	104.2	45	25560		341	400	136400		12	8.8	496	1200	2						
TB3	8427.3	2	8541.56	4	50	X	50	X	6	901.39	9.60	568	93.9	56	31800	3.8	341	400	136400	16	12	8.8	496	1200	2						
LB3	3069.05	4	8432.7	4	50	X	50	X	6	901.39	9.60	568	93.9	56	31800	10.4	341	400	136400	16	12	8.8	496	1200	2						
TBT6	3551.8	2		4	50	X	50	X	6	1000	9.60	568	104.2	45	25560	7.2	341	400	136400		12	8.8	496	1200	2						
LBT6	1845.26	1	315.29	2	50	X	50	X	6	1000	9.60	568	104.2	45	25560	13.9	341	400	136400	433	12	8.8	496	1200	2						
M4	61360.2	3	56478.1	2	101.6	X	101.6	X	6.35	1500	38.86	2412.9	38.6	331	410109	6.7	1448	400	579200	10	12	8.8	496	1200	6						
TB4	15062.66	4	15236.3	2	50	X	50	X	6	901.39	9.60	568	93.9	56	31800	2.1	341	400	136400	9	12	8.8	496	1200	2						
LB4	3765.86	4	11770.3	1	50	X	50	X	6	901.39	9.60	568	93.9	56	31800	8.4	341	400	136400	12	12	8.8	496	1200	2						
TBT7	4746.37	2	7769.22	1	50	X	50	X	6	1000	9.60	568	104.2	45	25560	5.4	341	400	136400	18	12	8.8	496	1200	2						
LBT7	13659.5	1	7631.1	2	50	X	50	X	6	1000	9.60	568	104.2	45	25560	1.9	341	400	136400	18	12	8.8	496	1200	2						
M5	87550.6	2	82176.6	4	101.6	X	101.6	X	6.35	1500	38.86	2412.9	38.6	331	410109	4.7	1448	400	579200	7	12	8.8	496	1200	6						
TB5	14909.8	2	15158.2	4	50	X	50	X	6	901.39	9.60	568	93.9	56	31800	2.1	341	400	136400	9	12	8.8	496	1200	2						
LB5	4301.78	4	12137.2	2	50	X	50	X	6	901.39	9.60	568	93.9	56	31800	7.4	341	400	136400	11	12	8.8	496	1200	2						
TBT8	7151.58	2	5519.5	1	50	X	50	X	6	1000	9.60	568	104.2	45	25560	3.6	341	400	136400	25	12	8.8	496	1200	2						
LBT8	7917.65	2	17613.8	1	50	X	50	X	6	1000	9.60	568	104.2	45	25560	3.2	341	400	136400	8	12	8.8	496	1200	2						
M6	112019.4	3	106446.9	2	101.6	X	101.6	X	6.35	1500	38.86	2412.9	38.6	331	410109	3.7	1448	400	579200	5	12	8.8	496	1200	6						
TB6	14952	4	14671.1	3	50	X	50	X	6	901.39	9.60	568	93.9	56	31800	2.1	341	400	136400	9	12	8.8	496	1200	2						
LB6	5968.4	4	13344.5	3	50	X	50	X	6	901.39	9.60	568	93.9	56	31800	5.3	341	400	136400	10	12	8.8	496	1200	2						
TBT9	5837.44	2	11072.93	3	50	X	50	X	6	1000	9.60	568	104.2	45	25560	4.4	341	400	136400	12	12	8.8	496	1200	2						
LBT9	16840.2	1	8677.72	2	50	X	50	X	6	1000	9.60	568	104.2	45	25560	1.5	341	400	136400	16	12	8.8	496	1200	2						

Table 2.6c Member design chart for full scale tower

DESIGN INPUT				COMPRESSION DESIGN						TENSION DESIGN				BOLTS DESIGN								
Member code	Max Comp. Fc	LC No.	Max Tension Ft. No.	LC	Paltruded Section Selected	Effective length	Radius of gyration r	Gross Area	K/r	Allowable stress σ_c	Member capacity Mc	FOS Mc/Fc	Net Area	Allowable stress σ_t	Member capacity Mt	FOS Mt/Ft	Bolt Dia	Bolt Cr	shear stress σ_s	bearing stress σ_b	No. of bolts	
	N		N		mm X mm X mm	mm	mm	mm ²	K/r	N/mm ²	N		mm ²	N/mm ²	N		mm		N/mm ²	N/mm ²		
M7	136292.2	3	130489.5	3	101.6 X 101.6 X 6.35	1500	38.86	2412.9	38.6	331	410109	3.0	1448	400	579200	4	12	8.8	496	1200	6	6
TB7	14958.3	3	14443.2	3	50 X 50 X 6	901.39	9.60	568	93.9	56	31800	2.1	341	400	136400	9	12	8.8	496	1200	2	2
LB7	7978.2	4	14754.5	4	50 X 50 X 6	901.39	9.60	568	93.9	56	31800	4.0	341	400	136400	9	12	8.8	496	1200	2	2
TBT10	10357	2	6527.47	3	50 X 50 X 6	1000	9.60	568	104.2	45	25560	2.5	341	400	136400	21	12	8.8	496	1200	2	2
LBT10	9687.47	1	22638.7	2	50 X 50 X 6	1000	9.60	568	104.2	45	25560	2.6	341	400	136400	6	12	8.8	496	1200	2	2
M8	163155.6	2	157061.7	2	101.6 X 101.6 X 6.35	1500	38.86	2412.9	38.6	331	410109	2.5	1448	400	579200	4	12	8.8	496	1200	6	6
TB8	14952.7	2	14448.95	2	50 X 50 X 6	901.39	9.60	568	93.9	56	31800	2.1	341	400	136400	9	12	8.8	496	1200	2	2
LB8	7291.77	4	14264.7	4	50 X 50 X 6	901.39	9.60	568	93.9	56	31800	4.4	341	400	136400	10	12	8.8	496	1200	2	2
TB11	6900.94	2	14408.24	2	50 X 50 X 6	1000	9.60	568	104.2	45	25560	3.7	341	400	136400	9	12	8.8	496	1200	2	2
LB11	21798.8	1	10513.27	2	50 X 50 X 6	1000	9.60	568	104.2	45	25560	1.2	341	400	136400	13	12	8.8	496	1200	2	2
M9	177150.8	3	171424.16	2	101.6 X 101.6 X 9.525	1500	37.60	3535.5	39.9	310	1093850	6.2	2121	400	848400	5	12	8.8	496	1200	6	6
TB9	16866.7	4	20792.78	1	50 X 50 X 6	1007.8	9.60	568	105.0	45	25560	1.5	341	400	136400	7	12	8.8	496	1200	2	2
LB9	21097.2	4	24985.6	1	50 X 50 X 6	1007.8	9.60	568	105.0	45	25560	1.2	341	400	136400	5	12	8.8	496	1200	2	2
T1	3864.48	3	2099.14	2	330		8.25	855.6	163.2	19	16256	4.2	513	400	205200	98	12	8.8	496	1200	2	2
B1	8874.71	2	1730.97	1			8.25	855.6	135.5	27	23101	2.6	513	400	205200	119	12	8.8	496	1200	2	2
T2	1179.95	2	2166.83	1	330		8.25	855.6	163.2	19	16256	13.8	513	400	205200	95	12	8.8	496	1200	2	2
B2	9638	3	1806.12	2			8.25	855.6	135.5	27	23101	2.4	513	400	205200	114	12	8.8	496	1200	2	2
T3	1213.49	2	2233.74	1	330		8.25	855.6	163.2	19	16256	13.4	513	400	205200	92	12	8.8	496	1200	2	2
B3	9610.17	4	1835.45	1			8.25	855.6	135.5	27	23101	2.4	513	400	205200	112	12	8.8	496	1200	2	2

2.6 Finite element analysis of cross arm with composite members

In the present work, a cross arm is modelled using a general purpose Finite Element Analysis software MSC-NASTRAN (AFEA2010.2.3). The developed model is used to verify the cross arm design and analyze the structural behavior. A 3-D Finite Element model is developed with HEX8 3-D solid element (eight noded element having three degrees of freedom at each node) for cross arm members with solid circular diameter of 33mm. Figure 2.9 shows the FE meshes of a cross arm with loads and boundary condition to account for its attachment to the tower body. The material properties of pultruded members used for analysis are shown in Table 2.7. The analysis also takes care of imperfect interface between the GE pultruded member and the metallic end fitting used for interconnection between members.

Table 2.7 Material properties used for FE Analysis

Sl.No	E_{11} MPa	E_{22} MPa	E_{33} MPa	ν_{12}	G_{12} MPa
1.	55000	18000	18000	0.25	7500

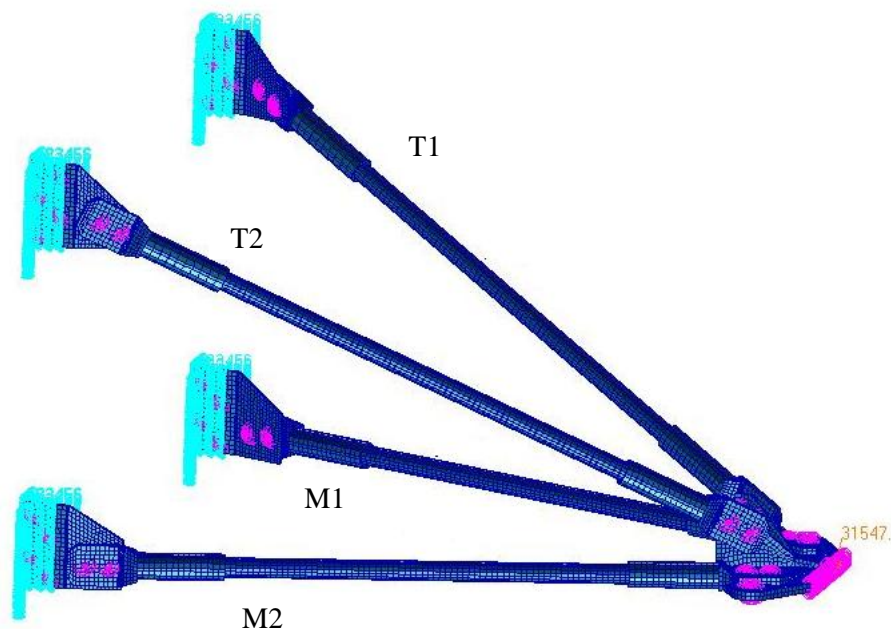

Fig. 2.9 FE mesh for cross arm with loads and boundary conditions

2.7 Finite element analysis of X-braced tower sub assembly

The 3-D X-braced tower sub assembly of a 66 kV tower with composite member is modeled in FEM software MSC-NASTRAN (AFEA2010.2.3). Tower sub assembly unit of 1.0 m x 1.0 m and a height of 2.0 m are considered whose geometric models are shown in Figure 2.10. The members of tower units are classified as leg members, bracing members and horizontal members. Three different prototypes of sub-assemblies are considered in the present work to study the behavior as listed in Table 2.8. Figure 2.11 displays the Finite element models of X-braced tower sub-assemblies and their loads and boundary conditions. The model is created using HEX8 3-D solid element (eight noded element having three degrees of freedom at each node). Constraints are provided to simulate the exact end conditions of the individual elements in the tower sub unit. The tower sub units are analysed for hinged base condition and hence, the degree of freedom of bottom most nodes are arrested for translation in all the direction letting the rotational degrees of freedom as free. The loads axially applied passing through the bolted connections.

Table 2.8 FE models of X-braced tower sub units / assembly

Sl. No	Details	Tower members	GE pultruded members	Size (mm)
1	TS-1	Leg member Bracing Horizontal	solid rectangular section Solid circular rod Solid circular rod	20x70 Ø20 Ø20
2	TS -2	Leg member Bracing Horizontal	solid rectangular section equal angle section equal angle section	20x70 50x50x6 50x50x6
3	TS-3	Leg member Bracing Horizontal	square hollow section equal angle section equal angle section	101.6x101.6x6.35 50x50x6 50x50x6

In a latticed tower, the cross bracings are generally subjected to compression and tension alternated. The behavior of the bracing members in a tower sub assembly is such that within each set of bracings, a bolt is introduced at the cross over. In the finite element model translation degrees of freedom perpendicular to the member axis are arrested and all other degrees of freedoms are allowed for this bolt.

A linear static analysis is performed for three prototypes for two load cases, one to simulate the normal service condition of transmission line towers (Reliability condition) and the other for the broken conductor case (Security condition). Prototypes are subjected to magnitude of loads suggested for above conditions to check the buckling strength of members.

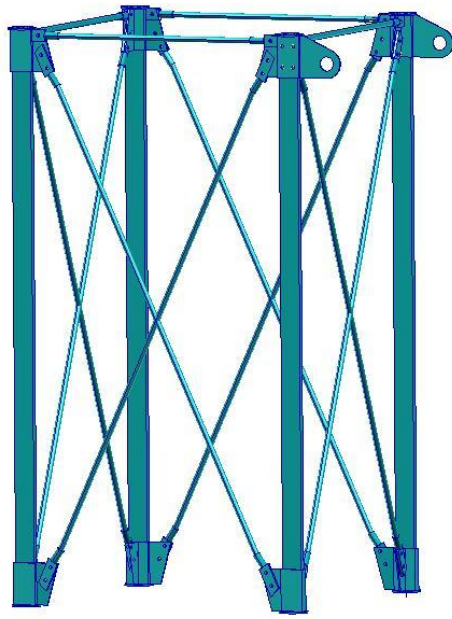

(a). Geometric Model : TS1

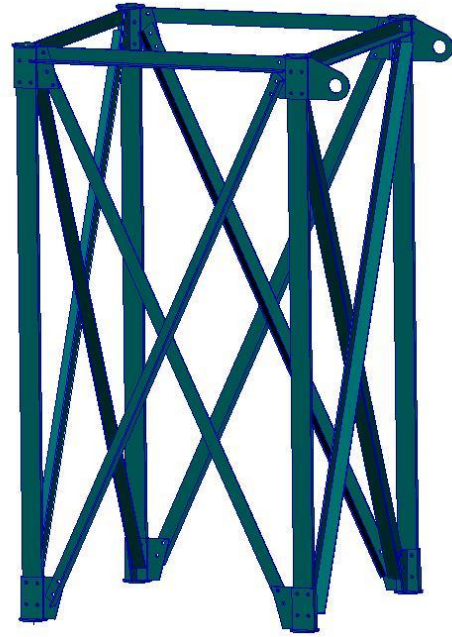

(b). Geometric Model : TS2

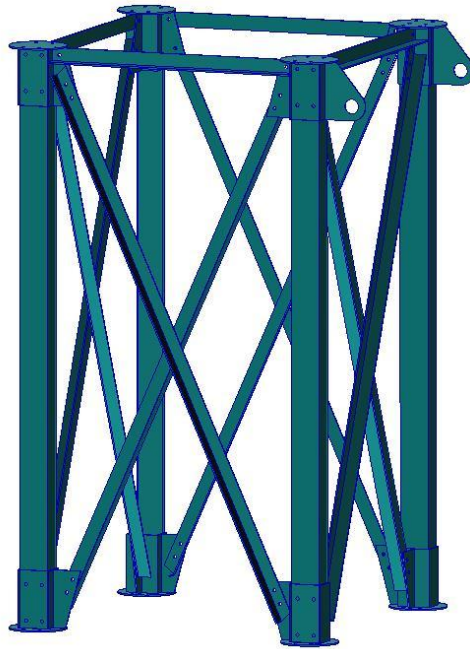

(c). Geometric Model : TS3

Fig. 2.10 Geometric models of tower units/ sub assembly

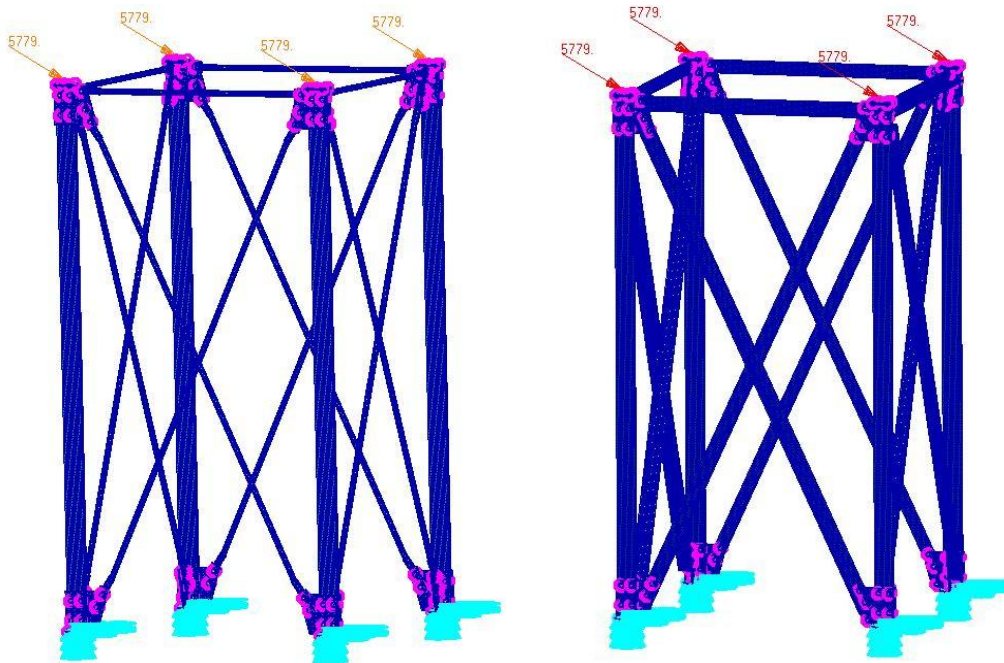

(a) Finite Element Model :TS1

(b) Finite Element Model: TS2

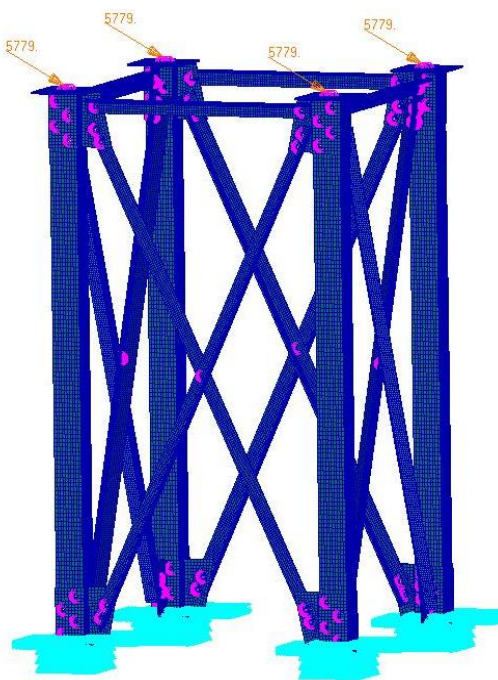

(c) Finite Element Model : TS3

Fig. 2.11 FE mesh with loads and boundary conditions for three tower units/ sub assembly

2.8 Finite element analysis of X-braced tower sub assembly with cross arm

Analysis of a tower sub assembly along with cross arm is envisaged in this section. The prototypes considered for the present work are given in Table 2.9. The prototype 1 has indicated buckling in one of the leg members at the suggested loads and thus is eliminated for further analysis. Two combinations of the tower units with cross arm are analyzed. TS2CA : TS-2 tower units with CA cross arm and TS3CA: TS-3 tower units with CA cross arm whose details are provided in Table 2.9. The 3-D X-braced tower sub assembly with cross arm on either side of a 66 kV composite tower is modeled in MSC- NASTRAN (AFEA2010.2.3) with panel dimensions of 1.0 m x 1.0 m and height of 2.5 m. Geometric models of these shown in Figure 2.11 and corresponding FE meshes with loads and boundary conditions are shown in Figure 2.13. The model is created using HEX8 3-D solid element (eight noded element having three degrees of freedom at each node). Like in the earlier case tower sub assemblies are analyzed for hinged base condition represented by degree of freedom bottom most nodes arrested for translation but not in rotational. The loads are applied at the tip of the cross arm as suggested in standard for different cases. Each proposal is analyzed for magnitude of loads suggested. The forces and stresses on each member are obtained for each load case and are compared. Further the same approach is extended to study the behavior of complete tower made from GE pultruded composite members.

Table. 2.9 FE models of X-braced tower sub assembly with cross arm

Sl. No	Details	Tower members	GE pultruded members	Size (mm)
1	TS2CA	Leg member Bracing Horizontal Cross arm	solid rectangle section } equal angle section } TS-2 equal angle section } solid circular section }	20x70 50x50x6 50x50x6 Ø33
2	TS3CA	Leg member Bracing Horizontal Cross arm	square hollow section } equal angle section } TS-3 equal angle section } solid circular section }	101.6x101.6x6.35 50x50x6 50x50x6

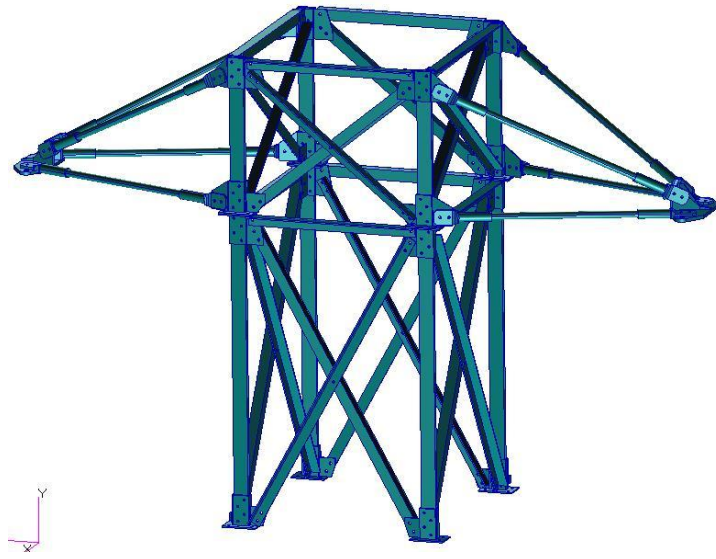

(a). Geometric Model: TS2CA



(b). Geometric Model: TS3CA

Fig. 2.12 Geometric models of tower sub assembly with cross arm

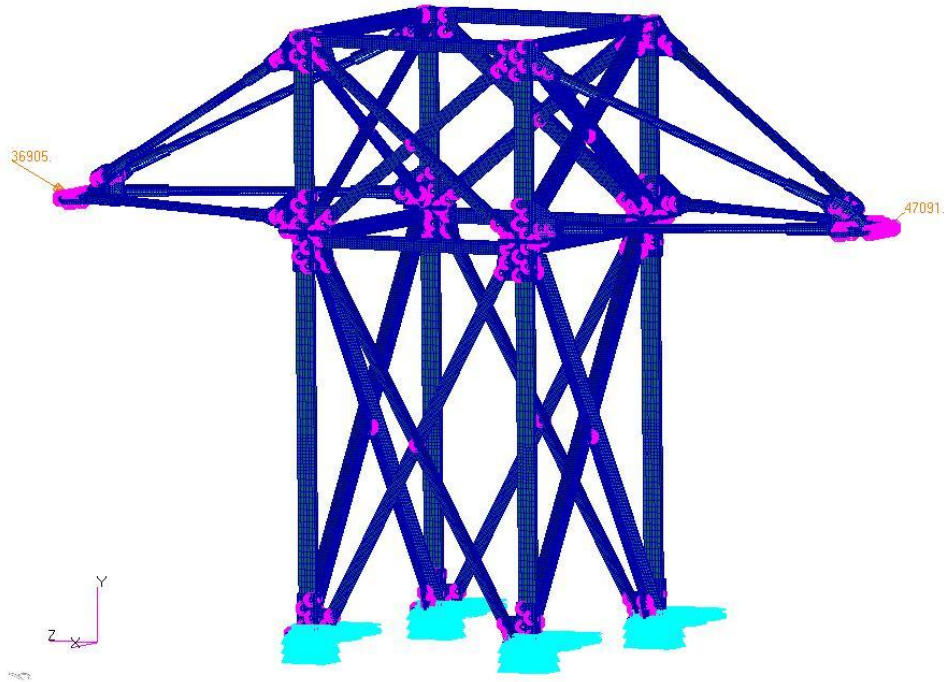

(a). Finite Element Model with loads and boundary condition TS2CA

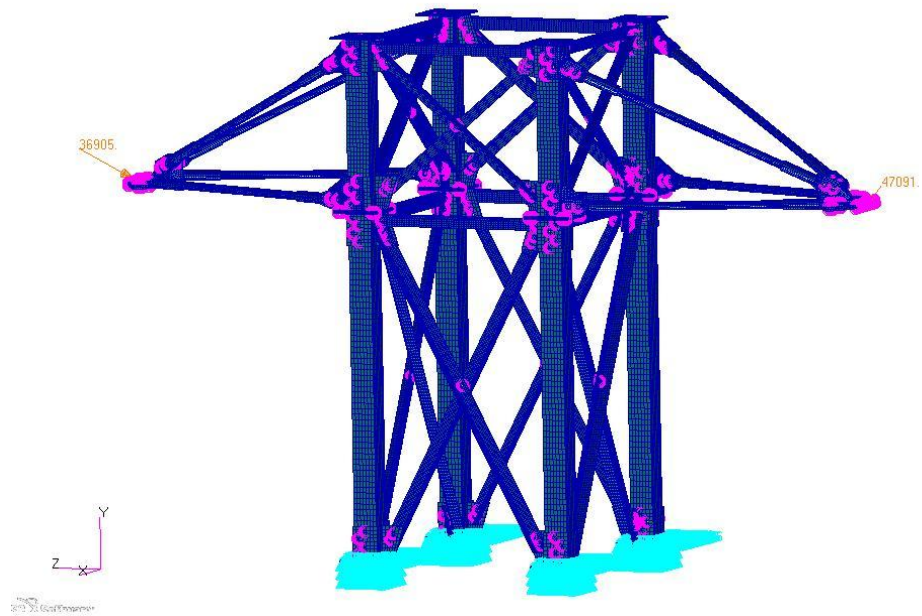

(b). Finite Element Model with loads and boundary condition TS3CA

Fig.2.13 FE meshes with loads and boundary conditions for tower sub assembly with cross arm

2.9 Structural FE analysis of full scale tower with composite members

The FE analysis of cross arm, tower sub units and tower sub assembly with cross arm made from composite members lead to building a full scale tower from composite members for study. Hence, this study is undertaken to construct a full scale tower with composite members. The objective is to assess the feasibility of the proposed full scale tower design with composite member with respect to mechanical strength and rigidity. The tower with composite members is designed based on electrical, functional and safety requirements. The structural analysis of 66 kV double circuit tower with composite members designed as explained in section 2.5 is carried out using a structural analysis software STAAD Pro V8i. For the purpose of structural analysis, the tower is idealized as a space truss. A space truss is a three - dimensional assemblage of linear members, each member being joined at its ends to the other members.

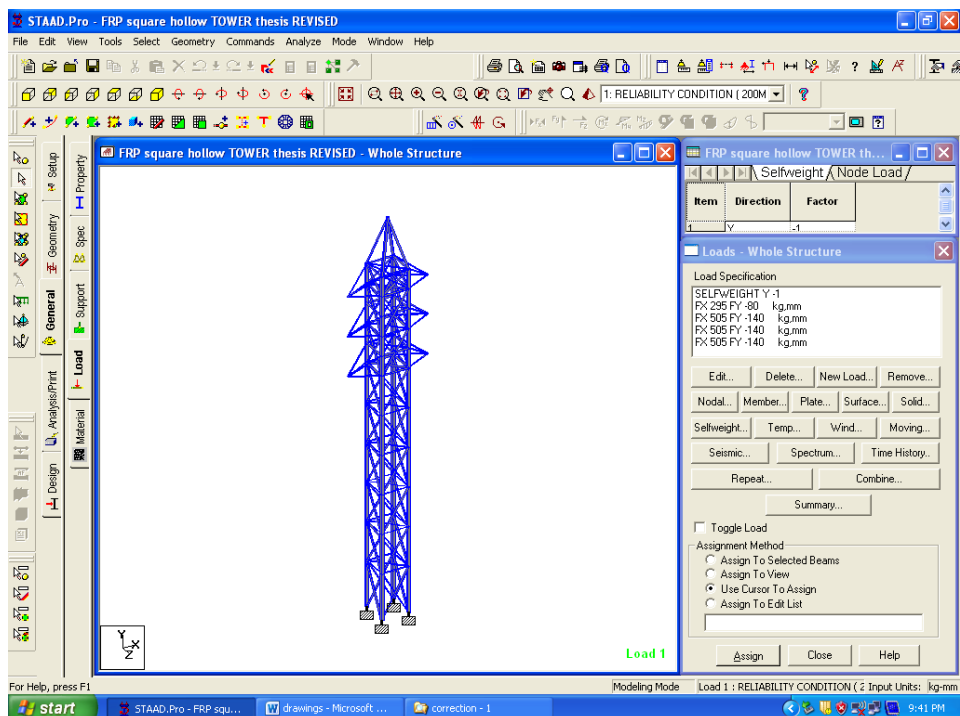

Fig. 2.14 3-D Geometric model of 66 kV double circuit full scale tower

Figure 2.14 shows the 3-Dimensional model of 66 kV double circuit tower with composite members 1.0 m x 1.0 m square base and a height of 15 m modeled using STAAD Pro software. Figure 2.15(a & b) shows the FE model with 3-D space truss idealization of tower consisting of leg members, horizontal bracing, and diagonal bracings and cross arm members. FE model of full tower consists of 59 joints with bottom four joints are completely restrained in all degrees of freedom to simulate the fixed support. Total number of elements is 246. All the loads and boundary conditions are applied on the tower model to simulate the exact service condition of the tower. From the analysis, stresses / forces on members are determined.

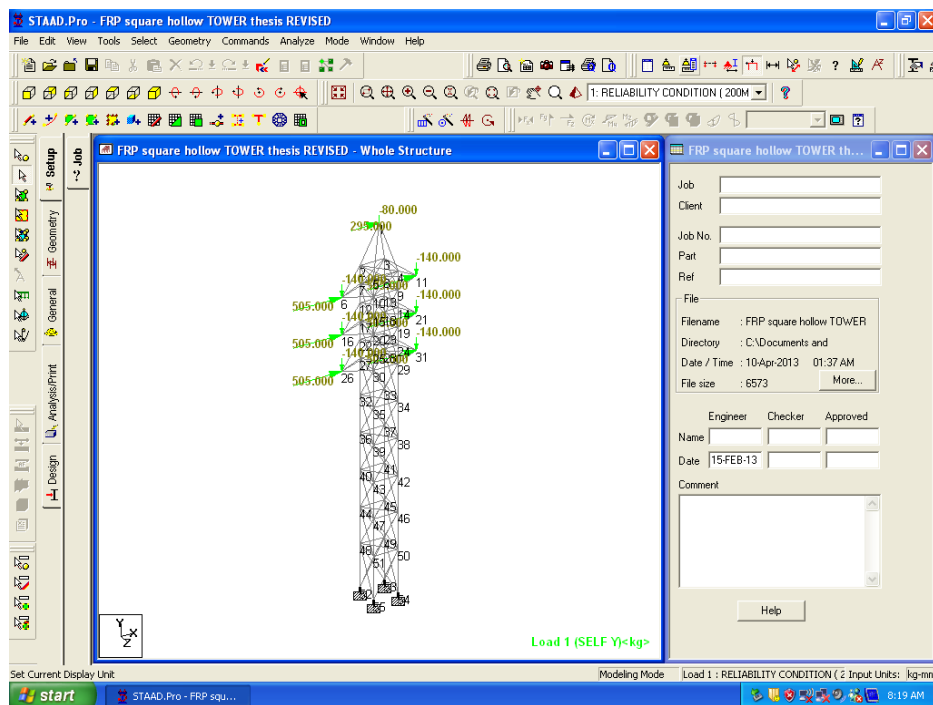

Fig. 2.15a Loads and boundary conditions applied on full scale tower

Initially, the tower geometry is determined based on the clearances suggested in standards followed determination of various loads on the tower.

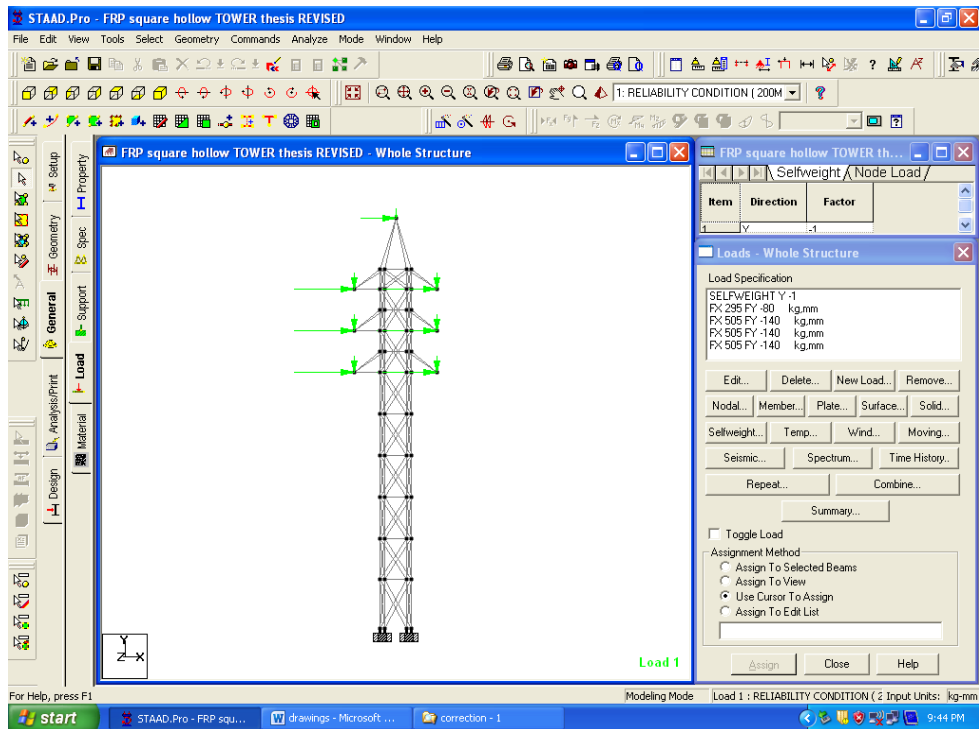

Fig. 2.15b FE model represents loading direction under reliability condition (Transverse and vertical loads)

Design of tower and its components is carried out as per the loads determined and the guidelines given in the standards. Verification of the design of cross arm, tower units/sub-assemblies, tower unit without and with cross arm and a full tower is envisaged with modeling and analyzing them for deformations and stresses in FE software package.

CHAPTER 3

3.0 PROCESSING AND EXPERIMENTAL TESTING

Consequent to design analysis of a tower with composite members using FEA as detailed in the earlier chapter, physical construction and experimental testing of the tower are carried out. This chapter furnishes the details of constructing and testing the tower. Initial part of the chapter contains details about characterizing physical, mechanical, accelerated weathering/ageing and electrical properties through testing of standard coupons and actual size tower members. The construction and testing of cross arm, X-braced tower units/sub-assemblies and a full scale tower all with composite members are detailed out in the latter part.

3.1 RAW MATERIALS AND METHODS

Composite members used for constructing the cross arm and tower are made from epoxy matrix and glass fiber reinforcement. Properties of these constituent materials are discussed here. E-Glass and L-12 Epoxy resin are used as reinforcement and matrix materials respectively. E-glass has better insulation properties and thus is suitable for our application. E-Glass 4800 TEX in roving form is used as a reinforcement material for fabrication of GE pultruded members for tower and cross arm.

Table.3.1 Properties of E-Glass and Epoxy resin

Properties	E-Glass	Epoxy resin
Density (g/cm^3) ρ	2.54	1.16
Tensile modulus E (GPa)	70	3.0
Tensile strength σ_t (MPa)	3400	80
Max. Elongation (%)	2.5	6.5

Epoxy resin Diglycidyl Ether of Bisphenol-A (DGEBA) known by commercial name Lapox (L-12) is used as a matrix material supplied by M/s ATUL India Ltd. Epoxy resin has been selected as the material for the matrix system because of its good mechanical properties, excellent corrosion resistance and ease of processing. Epoxy also has superior heat and electrical resistance. Room temperature curing polyamine hardener (K-6) also supplied by ATUL India Ltd is used. 5% talc powder is used as a filler material and 2% Zinc Stearate in powder form is used as releasing agent. Table 3.1 shows the properties of E-glass fibers and epoxy resin used for this study.

3.1.1 Manufacturing of composite members

As highlighted in chapter 1, Pultrusion is the ideal technology to produce long GE members with uniform cross sections. The pultruded members can be produced to any desired length. Pultrusion involves, dry fibers in roving form is pulled through a low-viscosity liquid mixture of thermosetting polymer and hardener. The wet fibers are then guided to a heated chrome plated steel die, where they are cured to set in the required form. The cross arm and tower members used in the present study are manufactured using pultrusion set up shown in Figure 3.1. The process parameters set are a pull speed of 70 mm/min and curing temperature of 150⁰C. Two automated hydraulic pulling system are used alternatively to pull the material. The members fabricated through pultrusion method are inspected visually for dimensional accuracy and defects.

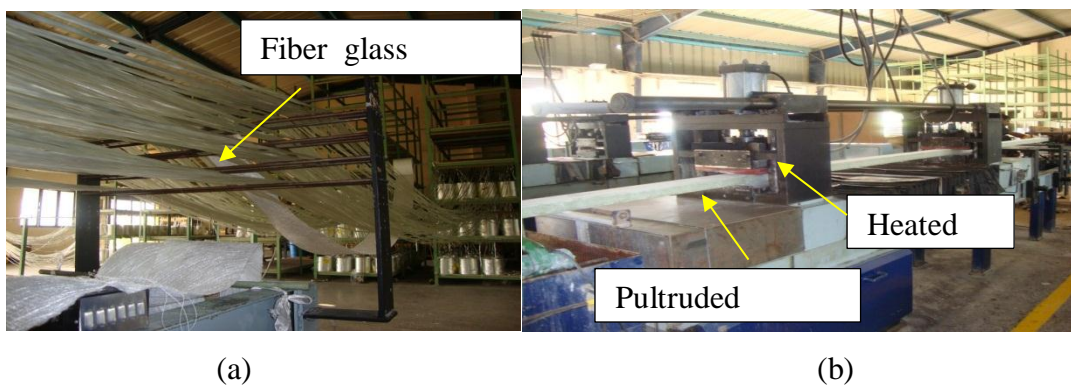





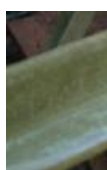



Fig. 3.1 Pultrusion process for fabricating composite members

(a) Fiber glass rovings going into pultrusion process

(b) Pultrusion set up

Different type of composite members made through pultrusion and their details are furnished in Table 3.2. Cross arm and towers are built from these composite members for testing.

Table 3.2 Details of GE pultruded cross arm and tower members

Sl. No	Member	Dimensions of member cross section	Reinforce - ment	Matrix	Manufacturer	Photo
1	Solid rectangle section	 20 mm x70 mm	E- Glass fibers : 70 - 75 %	Epoxy : 20-25% Lapox L12 Hardener K-6	M/s. Uniglass Industries, Bangalore	
2	Solid angle section	 50x50x6 mm 76.2x76.2x6.35	- do-	- do-	M/s. Uniglass Industries, Bangalore	
3	Solid circular section	 Ø30 mm, Ø33 mm	- do-	- do-	M/s. Goldstone Infrastructure Ltd, Hyderabad	
4	Hollow sections	 101.6x101.6x9.52 101.6x101.6x6.35	- do-	- do-	M/s. KEMROCK Industries, Gujarat.	

3.2 Characterization of GE pultruded material through standard tests

As a preliminary study, properties of the GE pultruded material are determined. The standard coupons of GE pultruded materials are cut in accordance with standard specimen sizes recommended. These coupons are tested for physical, mechanical, electrical and accelerated weathering properties as per respective ASTM standard.

3.2.1 Testing for physical properties

GE pultruded composite material to be used for tower and cross arm members is tested for physical properties such as specific gravity/density and water absorption.

The specific gravity test is carried out in accordance with ASTM D792-00 with suggested specimen size of 25x23x8 mm. The specimen is weighed in air and then in distilled water. The specific gravity of the specimen is then calculated using relation 3.1. This procedure is repeated and average of specific gravity/density is recorded.

$$\text{Specific gravity} = W_1/W_1.W_2 \quad (3.1)$$

Where, W_1 - Weight of the specimen in air

W_2 - Weight of the specimen under distilled water

The absorption of moisture by GE pultruded material could influence the electrical properties, mechanical strength, dimensional stability and appearance of the members. Thus water absorption test is conducted for the material in accordance with ASTM D570 -98. Specimen with suggested size of $\text{Ø}25.4\text{mm}$ and 25.4 mm long are cut and their weights are recorded. The specimens are then immersed in a container of distilled water maintained at a temperature of $23 \pm 1^\circ\text{C}$. After 24 hours, the specimens are removed from the water one at a time, all surface water wiped off with a dry cloth and weighed in a precision balance. The difference in weight gives the amount of water absorption by the specimen. The % of water absorption is calculated as below:

$$\% \text{ of water absorption} = [W_2 - W_1 / W_1] \times 100 \quad (3.2)$$

Where, W_1 - Weight of the specimen before immersion

W_2 - Weight of the specimen after 24 hours immersion in distilled water

Percentage of water absorption is then recorded for each sample and the average is determined.

3.2.2 Evaluation of mechanical properties

It is envisaged in this section to test the coupons of the GE pultruded material to evaluate its mechanical properties in tensile, compressive and flexural loading conditions.

The tensile strength on standard sample of pultruded material is performed according to ASTM D638 - 08. Figure 3.2 shows two types of specimens are prepared with dimensions confirming to the above standard. Tensile test is carried out in a 100 kN capacity Shimadzu make servo controlled Universal Testing Machine (UTM) for a loading range of 0.1 kN to 100 kN. Figure 3.3 shows the test set-up with self-aligning grips used to ensure axis of the test specimen coinciding with the direction of applied pull. The test specimens carry strain gauges bonded in fiber direction and perpendicular to fibers to indicate linear and lateral strain(x and y directions) during testing. Tensile strength and modulus for various samples are tabulated and the average properties are noted and recorded.

The compression test is performed in accordance to ASTM D 349-07, ASTM D 695-08 (2002) using 50 kN microprocessor controlled Universal Testing Machine with a loading capacity ranging from 0.1 kN to 50 kN. Figure 3.4 shows details of compression test. The test specimen of 8 mm x 8 mm and height 25 mm are used. The axial load is applied gradually perpendicular to the faces of the specimen. The crosshead speed of 1.3 mm / min is maintained during testing. The load deflection data is recorded at equal intervals till the specimen shows the first sign of failure.

The three point flexural test is carried out in accordance with ASTM D790 on a Universal Testing Machine of range 0.1N to 50kN. Figure 3.5 shows the flexural test set-up. The test specimen of 15mm x 6mm and length of 100 m are used. The crosshead displacement rate is maintained at 5.0 mm/min as suggested in the above standard. The load deflection data is recorded at equal intervals till the specimen shows the first sign of failure. From load deflection data, the flexural strength is estimated using relation 3.3.

$$\text{Flexural strength} = 1.5 WL/BD^2 \quad (3.3)$$

Where, W – breaking load (N)

L – span between supports (mm) B – width (mm) D - thickness (mm)

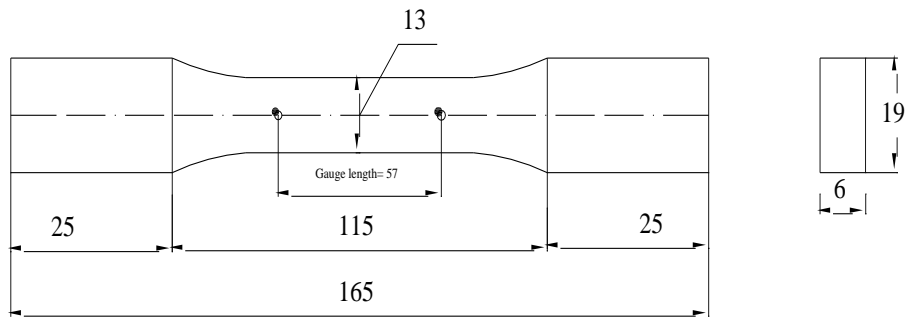

(a) Rectangle section

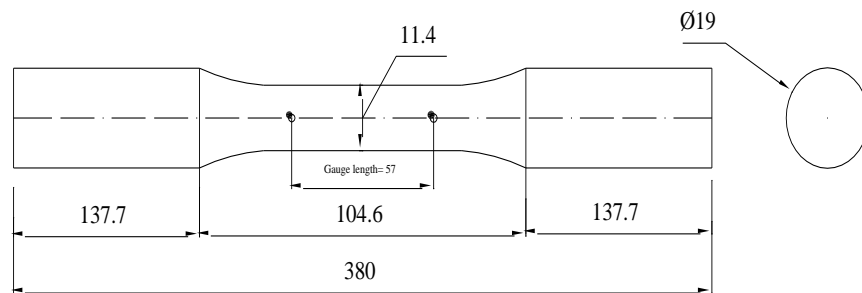

(b) Circular section

Fig 3.2a and b. Dimension of suggested tensile test specimen in ASTM D638-08



(c) Rectangle section



(d) Circular section

Fig 3.2 c and d. Photograph showing tensile test specimens of on GE pultruded members



Fig.3.3 Photograph showing tensile strength test set up



(a)

(b)

Fig 3.4 Photograph showing (a) test set up and (b) specimen under Compression test



Fig 3.5 GE pultruded sample mounted on flexural test-up

3.2.3 Accelerated weathering/ageing test - Xenon arc method

The aim of the test is to evaluate the effect of sunlight and rain or dew on the tower material. The test is conducted in accordance with IEC 4892-2:1994 (E) and ASTM G155 standards. Standard sized samples of 19 mm x 6 mm and length 200 mm are exposed to repetitive cycles of light and moisture under controlled environmental conditions. In order to check the effect of coating on the specimens when it is exposed to accelerated weathering, two different sets of specimens are prepared one with enamel coating and other is without coating. The samples are prepared The test apparatus used is Ci4000 Xenon Weather- Ometer and the test details are shown in Figure 3.6.



Fig 3.6a Test set up of accelerated weathering test

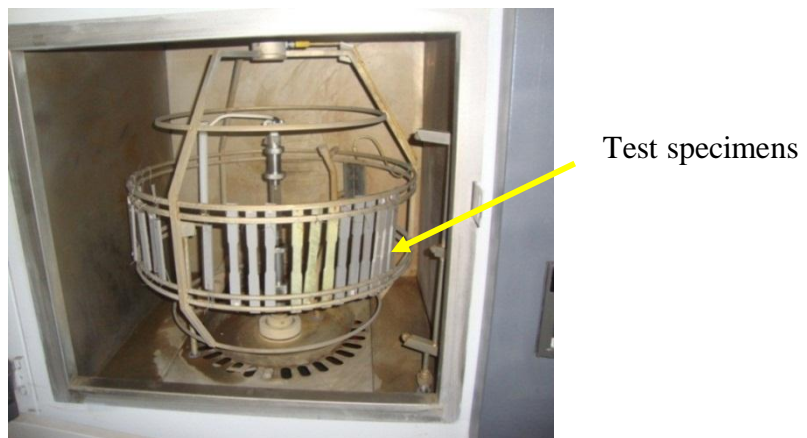

Fig 3.6b Picture of test specimens mounted on the specimen holder

The following test parameters are set for the accelerated weathering test:

Type of light source and wattage : Xenon Arc Lamp, 6500 W , water cooled

Spectral radiation at sample location : 0.5 W/m^2 at wavelength of 340 nm

UV exposure conditions : Artificial weathering (Method A)
without dark periods

Exposure cycle : 102 min light at $63 \pm 3^\circ \text{ C}$ black standard
temperature 18 min light and water spray

Type of spray water: Water purified by deionization and reverse osmosis

Operating relative humidity : $50 \pm 5\%$

Size of the test specimen : 120 x 16x 6 mm

Total test duration / period of UV exposure : 1000 hrs

The test specimen is exposed to 500 cycles, each cycle takes about 2 hours (102 minutes light at 65° C and 18 minutes light with water spray). The specimen is exposed continuously through the test duration.

3.2.4 Erosion test on GE pultruded material

The erosion test is conducted in accordance with ASTM G65 standard. Standard sized samples of 25mm x 6mm and length 75mm are used and tested before and after accelerated weathering test. The nozzle of diameter 5mm, silica sand with particle size of 355 μm are selected. Figure 3.7 shows the erosion test set-up and the test is carried out for 90° and 45° jet angles which are shown in Figure 3.8.

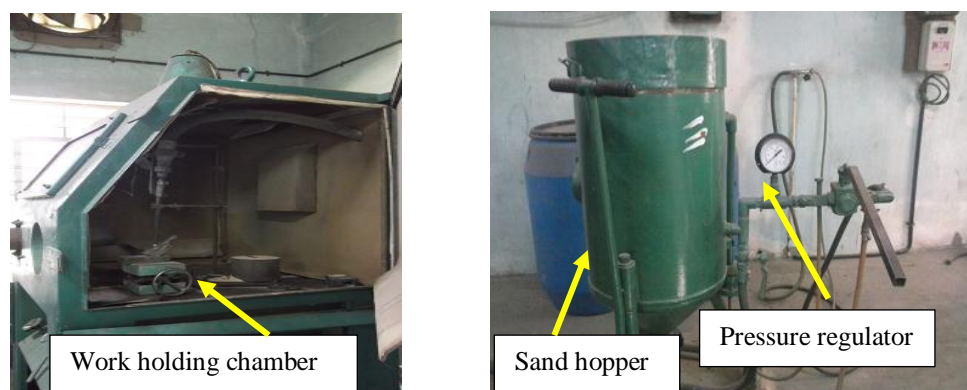

Fig 3.7 Test set up for erosion test

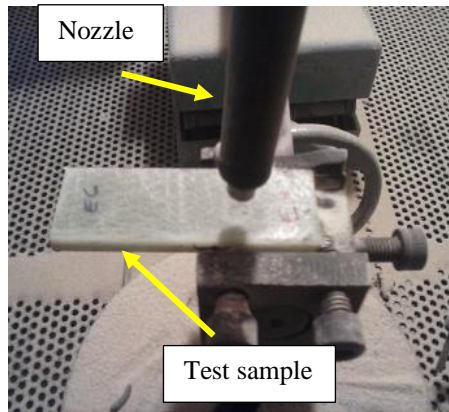
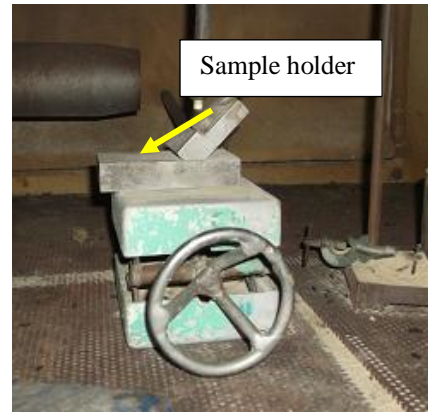

Fig 3.8 (a) Erosion test with nozzle at 90°



(b) Erosion test with nozzle at 45°

3.2.5 Testing of tower material for dielectric breakdown

In actual service, the dielectric breakdown of tower material can cause the tower to conduct and result in hazards. The dielectric strength is defined as the breakdown voltage per unit thickness of the material. The dielectric strength of the GE pultruded material is tested in accordance with ASTM D-149. Specimens of size 150x40x3 mm are prepared to conduct the dielectric strength test. The test specimens are immersed in oil bath maintained at 90°C temperature as shown in Figure 3.9. Voltage is applied across the ends of specimen through electrodes. Voltage at the time of flashing in specimen is noted and recorded as volts per thickness (kV/mm) indicating the dielectric strength.

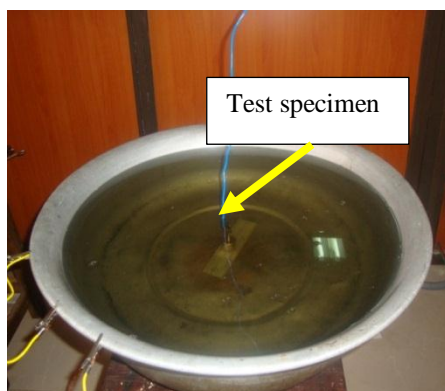

(a)



(b)

Fig 3.9 (a) Test specimen immersed in oil bath for dielectric testing

(b) Apparatus for applying voltage in di-electric strength test

3.3 Testing of actual size tower members for mechanical properties

To ascertain the suitability of GE pultruded members in tower applications, testing them in actual scale for mechanical properties is carried out. GE pultruded members used in the present work are square hollow tubes, angles, circular rods, rectangle sections (Table 3.2). These are tested in standard test conditions and the details are given below:

3.3.1 Testing of actual size member for tensile strength

Composite test samples of length 1000mm are prepared for every sections in Table 3.2 which go in building full scale tower. Tensile test is carried out using 200 kN capacity hydraulic loading device with tower members carrying suitable metallic sleeves attached to both ends with either adhesive or through a riveting. GE pultruded members with their sleeves are subjected to axial tension test for their bonding strength. Figure 3.10 (a -d) show the setup for tensile test of GE pultruded members.

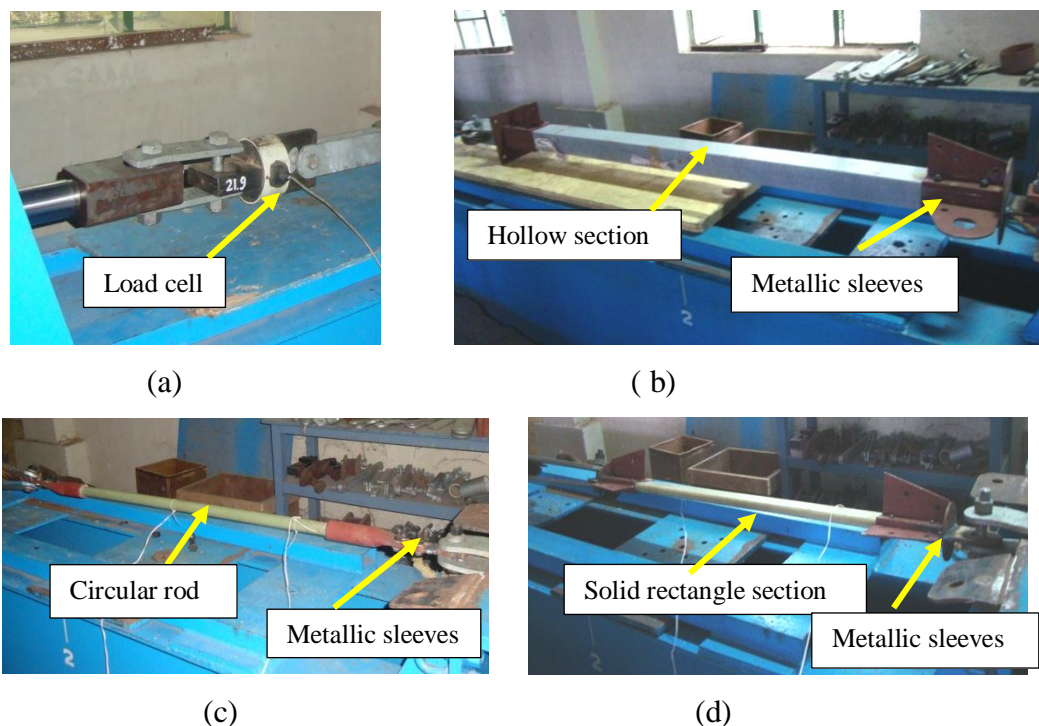

Fig 3.10 Picture showing tensile strength tests of tower members
(a) Load cell (b) Square hollow member (c) Rectangular member
and (d) Circular rod

3.3.2 Testing of actual size members for buckling strength

Tower members are generally axially loaded and sustain buckling under compressive loads. Thus attempt is made to test actual size tower members for buckling strength. 500 mm long samples with pultruded sections mentioned Table 3.2 used for building the tower are tested. Figure 3.11 shows the setup for buckling test using computer controlled UTM of 1000 kN capacity.

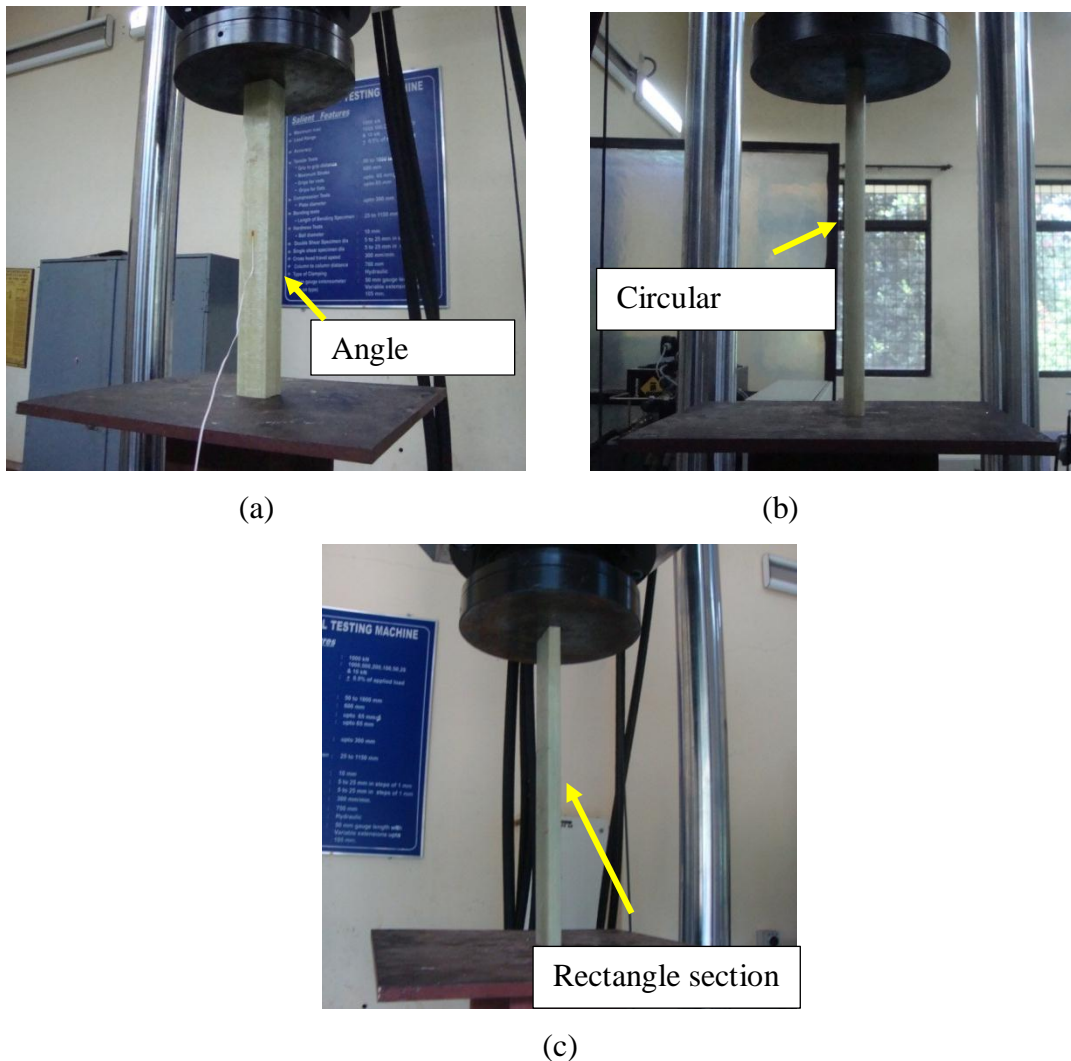

Figure 3.11 Picture showing test for buckling strength of members with cross sections of (a) Angle (b) Circular and (c) Rectangle

3.3.3 Testing of actual size members for flexural strength

The testing of actual size GE pultruded members is carried out using 150 kN three point bending machine for flexural strength. Figure 3.12 shows the details of test set-up. The load deflection data is recorded at equal intervals until first sign of failure of the specimen. From load deflection data, the flexural strength is estimated using relation 3.4 and 3.5 and the average flexural strength is recorded.

$$\text{Flexural strength} = 1.5 WL/BD^2 \text{ for rectangular section} \quad (3.4)$$

Where, W – breaking load (N)

L – span between supports (mm)

B – width (mm)

D - thickness (mm)

$$\text{Flexural strength} = 3WL/\pi r^2 \quad \text{for circular section} \quad (3.5)$$

r - radius of circular section

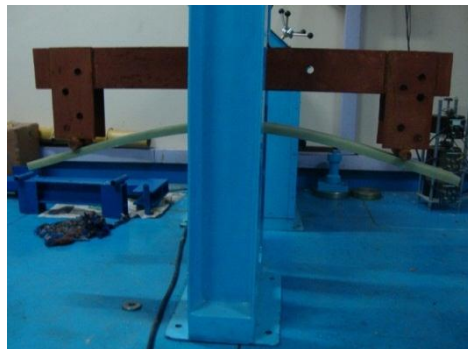

(a) Rectangle section

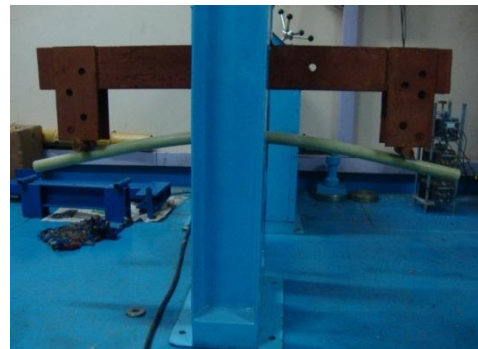

(b) Circular section



(c) Test setup

Fig.3.12 Picture showing flexural testing of members

3.4 Preparation of pultruded cross arm members with sheds

Figure 3.13 represents the geometry of a GE pultruded member used for building the cross arm of an overhead transmission line. This comprises of a solid core, metal end-fittings and silicone rubber housing with sheds. The core is a composite pultruded rod which sustains mechanical loads. The composite rod is manufactured by pultrusion process discussed earlier. The end-fittings that connect cross arm members to tower members are made of mild steel. The metal end fittings are attached to the end of rod in two ways mentioned in the next section. The silicone rubber sleeve with sheds, disc/skirt like projections to provide electrical insulation and protection. The sleeve with sheds is laid on the composite rod using continuous moulding process. A composite cross arm suitable for a 66 kV overhead power transmission line system is built from GE pultruded members as per recommendations in IS:5613 (Part-2/Sec-1):1985 and IS: 802 (Part-1/Sec-1):1995 RA 2006 whose geometrical parameters are shown in Figure 3.13.

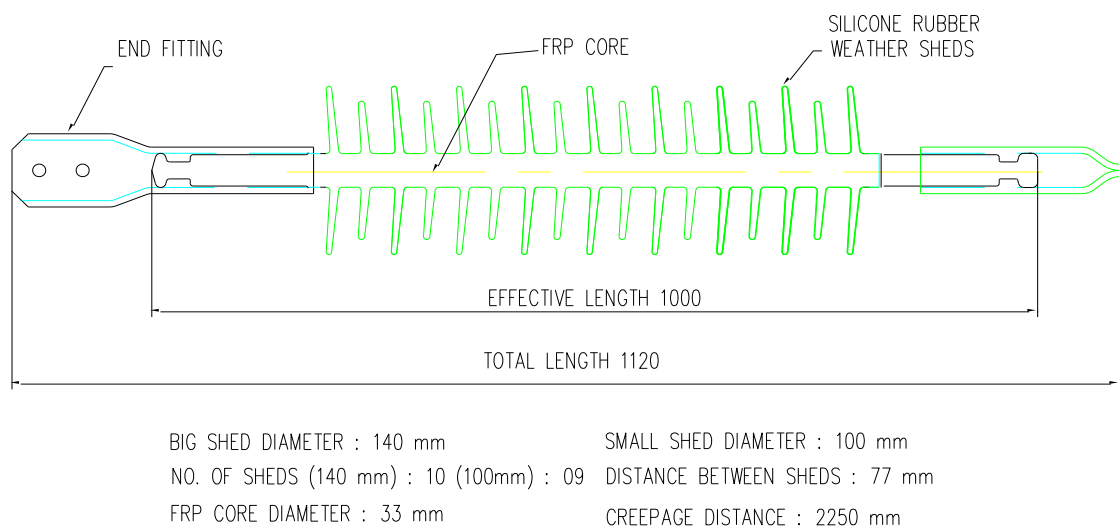

Fig.3.13 Geometry of composite member used for cross arm showing rubber sleeve, end fitting and sheds

3.4.1 Development of end fittings for cross arm members

Cross arm members prepared as discussed in the earlier section are assembled into a full scale cross arm. Members are fitted with metallic clamps at both the ends of GE pultruded rod to aid in joining different members as well as cross arm to tower body. Two types of attaching end clamps are considered viz., adhesive bonding with epoxy glue & crimping process. Figure 3.14 shows the suitable end clamps developed for

cross arm members fitted either by epoxy adhesive or by crimping.



Fig.3.14 Photograph of composite cross arm member with end fittings

Figure 3.15 shows 5395 KN capacity crimping machine where end clamps are fitted on to cross arm members. Members with both types of end fittings are tested for their bonding strength before actually using them in the tower/cross arm construction. Figure 3.16 shows a stack of composite members with crimped metallic clamps on both ends.



Fig 3.15 Crimping machine set up



Fig 3.16 Composite cross arm members showing crimped end fittings

The bonding strength at metallic end clamps is determined using 200 kN hydraulic loading device. Figure 3.17 a and b shows test set up to determine bonding strength. Tensile load is applied gradually in steps of 500 N and the strain data is recorded using the 8 channel dynamic strain recorder is shown in Figure 3.17c at equal intervals till the end clamps shows signs of slippage. Load and strain values corresponding to this condition are noted. It could be noticed from Figure 3.17d and e, that the clamps fitted with crimping remained intact while those with adhesive bonding slipped early during loading. Hence, for subsequent construction of cross arm, members with metallic end clamps fitted with crimping are used.



(a) With crimped metallic end fittings and weather sheds



(b) With adhesive bonded metallic end fittings without weather sheds



(c) Dynamic strain recorder set up



(d) End clamps with crimping remaining intact after loading



(e) End clamps with adhesive bonding slipping early during loading

Fig.3.17 Picture showing cross arm members with end clamps tested for bonding strength

3.4.2 Assembly of cross arm with composite members

The top view and front view of the cross arm assembly constructed from the composite members with end clamps and shed are shown in Figure 3.18. The cross arm is composed of two horizontal main members with an angle of 53° (γ) in horizontal plane to resist longitudinal loads and transverse loads and has two suspension tie members at an angle of 24° (β) in vertical plane to resist vertical loads and avoid any imbalance in the stress distribution. These members are joined to each other and to tower body with suitable end clamps as discussed in the earlier section.

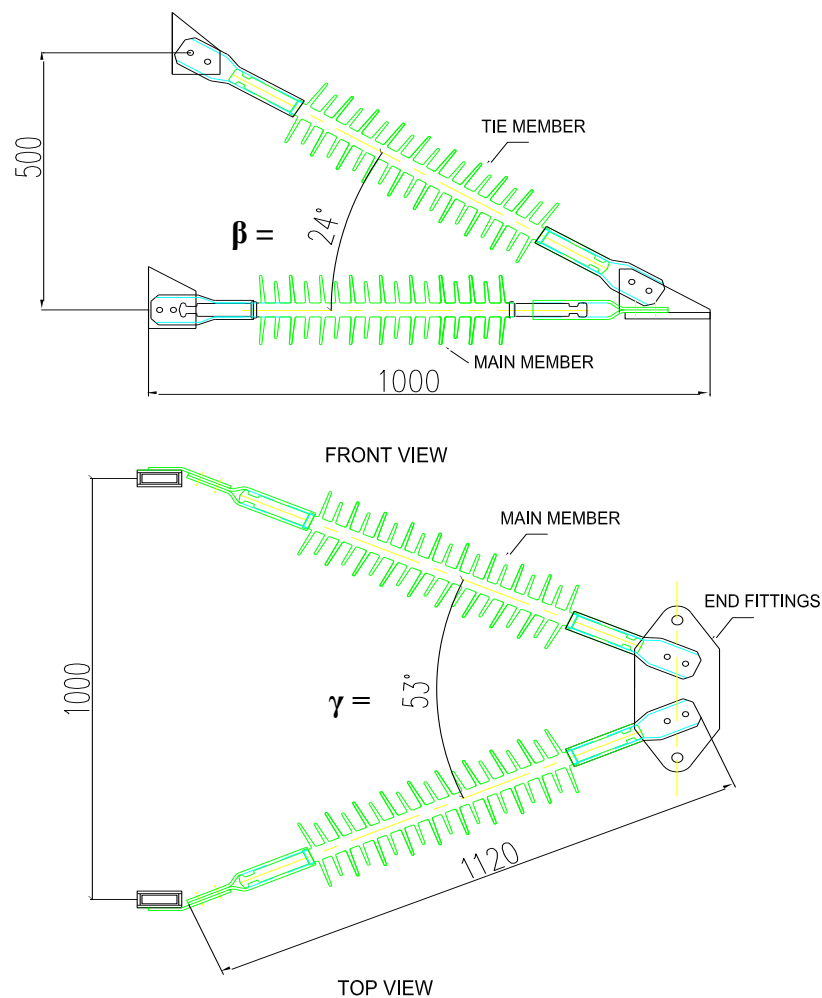

All dimensions in mm

Fig 3.18 Font and top view of composite cross arm assembled from pultruded composite members

3.4.3 Mechanical testing of cross arm assembly with composite members

To study the performance, cross arm assembly with composite members is mounted on portion of a tower fixed to ground. Loads are applied at the cross arm tip in longitudinal, vertical and transverse direction as per IS: 802 (Part-III): 1978 RA 2006. The schematic of the test setup is shown in Figure 3.19a. Loads are applied on the cross arm through calibrated load cells at the tip of the cross arm. Figure 3.19b is a photograph showing the cross arm mounted on the base for testing.

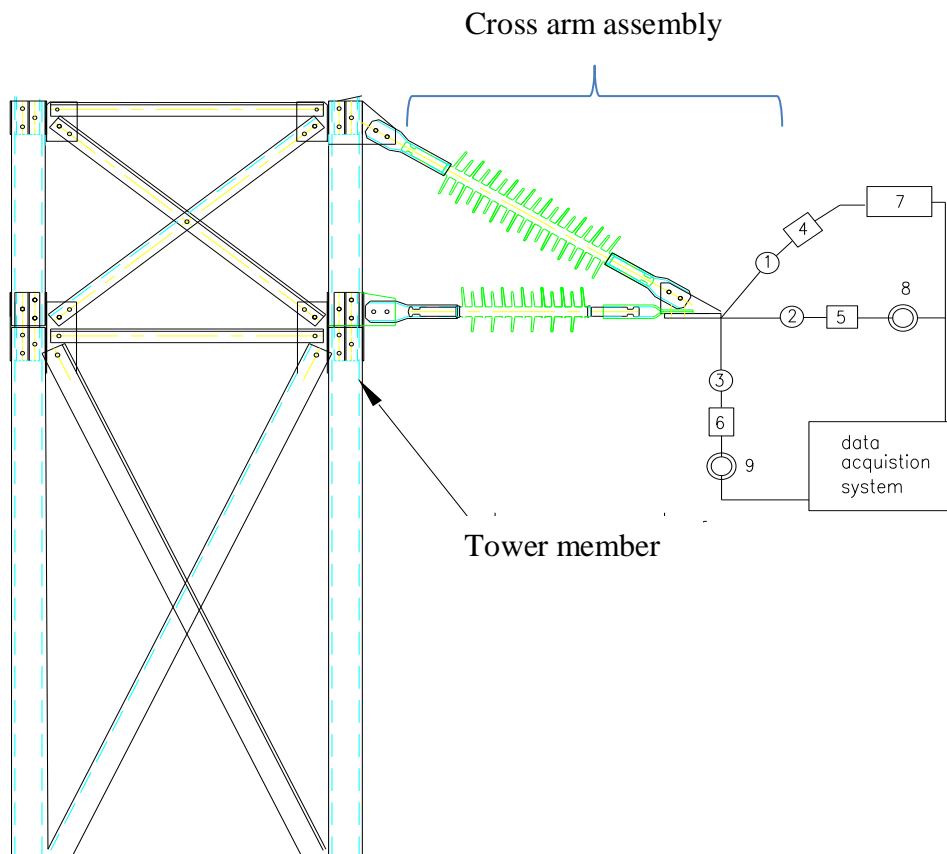

1, 2, 3- Rod end bearing, 4, 5, 6- load cell, 7- Hydraulic loading

8, 9- Chain pulley loading

Fig. 3.19a Schematic diagram of cross arm mounted on tower for mechanical testing



Fig. 3.19b Photograph of cross arm with composite members subjected to mechanical testing

3.4.4 Testing procedure in reliability and security condition

Loads for a typical cross arm of 66 kV line as suggested in IS: 802 (Part 1/ Sec 1): 1995 (Ref. loading tree 2.6) are applied on the cross arm assembly gradually to avoid any impact loading. All three directions loads are varied in steps of 50%, 75%, 90%, 95% and 100% of full load as suggested in IS:802 (Part-3):1978. Deflection of the tip of cross arm is recorded for each loading step using optical theodolite. Loads are sustained at each level for two minutes to observe any visible signs of failure. Loads corresponding to three conditions of performance, Reliability, Security and Safety are mentioned in Table 2.3 are applied for testing.

In reliability condition as suggested in standard IS: 802 (Part 3) only vertical and transverse loads are applied simultaneously in steps. In case of security condition, vertical and transverse loads are kept constant while longitudinal load is gradually applied representing broken wire. In safety condition, transverse and increased vertical loads which represent maintenance condition are applied simultaneously. No sign of visible failure during the application of loads in each for 2 minutes implies the integrity of the cross arm under service condition.

3.5. Mechanical performance test of X-braced tower sub assembly

Subsequent to construction and testing of cross arm, testing of a portion of the tower is carried out. A tower unit/sub assembly of dimension 1.0m x 1.0m base width and a height of 2.0 m is identified and three different prototypes are proposed as furnished in Table 3.3. Construction of the tower sub assembly involves connection of bracing members to leg members with M12 bolts. The typical schematic view of the X-braced tower unit/sub assembly constructed is shown in Figure 3.20.

Table 3.3 Details of three prototypes of X-braced tower unit/sub assembly

Sr. No.	Details	Tower members	GE pultruded members	Size (mm)
1	TSA-1	Leg member Bracing Horizontal	solid rectangular section Solid circular rod Solid circular rod	20x70 Ø20 Ø20
2	TSA -2	Leg member Bracing Horizontal	solid rectangular section equal angle section equal angle section	20x70 50x50x6 50x50x6
3	TSA-3	Leg member Bracing Horizontal	square hollow section equal angle section equal angle section	101.6x101.6x6.35 50x50x6 50x50x6

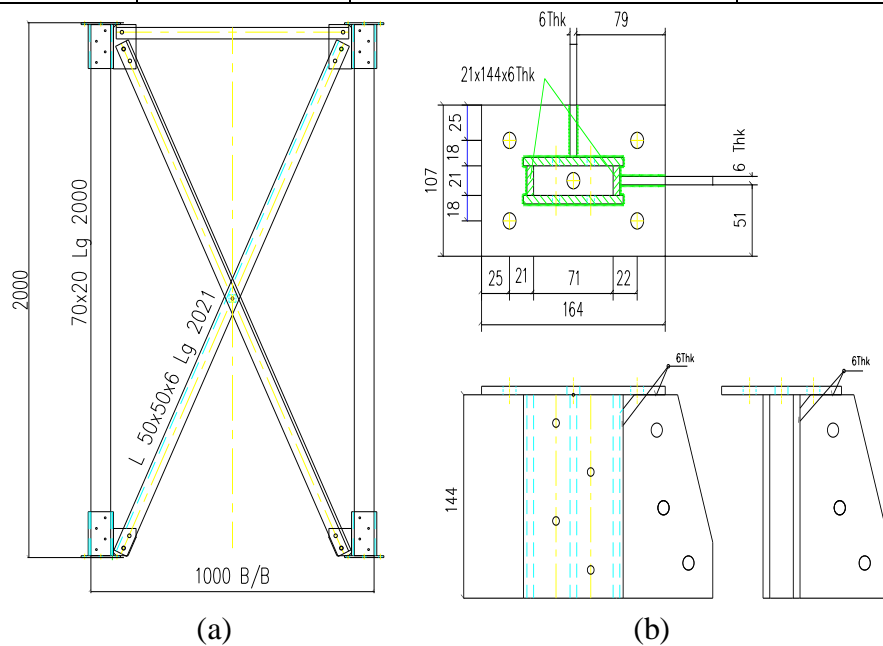
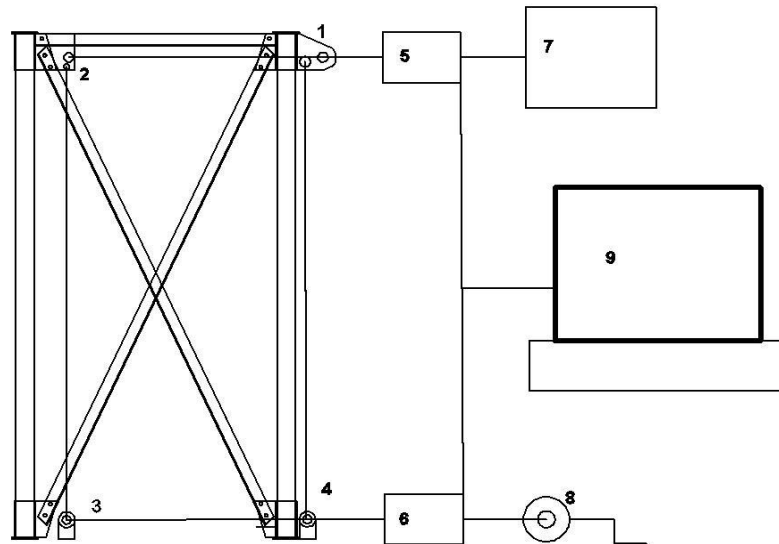

Figure 3.20 Schematic view of (a) X-braced tower unit / sub assembly
(b) Details of connections to leg members

Figure 3.21 shows the schematic of the test set up for X-braced tower units / sub-assemblies. The loads applied and strains are measured using calibrated load cells and strain gauges mounted on members respectively using 16 channel MCE 1000 DAQ system to record them. Figure 3.22 a, b and c are photographs showing testing of three proposed prototypes of tower sub-assemblies until failure. Initially test is conducted with all loads set at 25% of full load and the strains are noted. Then loads gradually removed and applied again up to 25% of full load. This is repeated thrice to ensure the repeatability of strain readings. Then the load is incremented to 50%, 75%, 90%, 95% & 100% of full load as suggested in IS: 802 (Part 3). The overall deflection of the top of the assembly at 100% full load is recorded using displacement transducer.



1, 2, 3, 4 - Pulley block, 5, 6 - load cell
 7 - Hydraulic loading device, 8 - Chain pulley loading
 9 - Data acquisition system

Figure 3.21 Schematic of test set up for tower sub assembly

The testing is done in all three conditions, reliability, security and safety conditions explained earlier. The tower units/sub-assembly is deemed to satisfy testing, if there is no visible sign of failure during the load application for a period of 5 minutes as per IS: 802 (Part 3). After ensuring integrity at the suggested full load, loading is continued up to failure to obtain the load carrying capacity of the tower unit.



(a)



(b)



(c)

Fig. 3.22 Photograph showing the mechanical testing of tower sub assembly

(a) TSA - 1, (b) TSA - 2, (c) TSA - 3

3.5.1 Mechanical performance of X-braced tower sub assembly with cross arm

The X-braced tower unit/sub assembly discussed earlier along with a cross arm mounted in position representing a portion of the actual tower is constructed as shown in Figure 3.23. The testing of tower sub assembly with cross arm mounted is carried out in the similar way as discussed before for reliability, security and safety conditions explained earlier. The strain gauges are mounted on the cross arm and tower unit members at eight and sixteen critical locations respectively identified through FE analysis as shown with schematic in Figure 3.24 a and b. Figure 3.25 a, b and c show the photograph of strain gauges mounted on cross arm and tower unit. The output of these strain gauges are connected to a 16 channel MCE 1000 DAQ system shown in Figure 3.26 with LabView software to record at a sampling rate of 300 per second. The data acquisition is automatic and data is recorded for off line viewing. Loads corresponding to the standard testing conditions are set at required steps for a period suggested in standard IS: 802 (Part 3). The integrity of the structure is verified if there is no visible failure.



Fig. 3.23 Photograph showing mechanical testing of X-braced tower unit with cross arm prototype TSCA2.

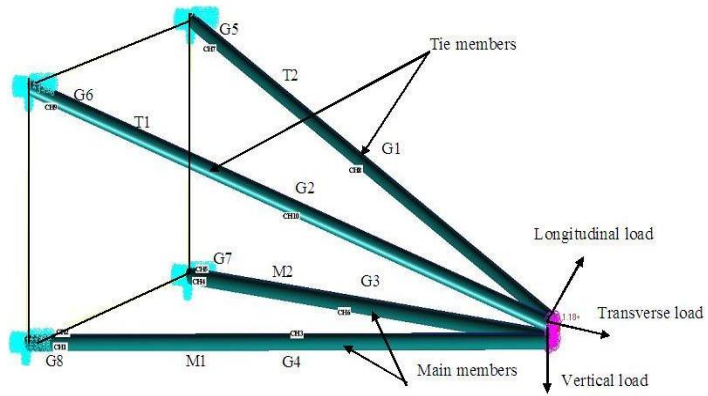

Fig 3.24 a. Schematic of strain gauge locations on the cross arm members

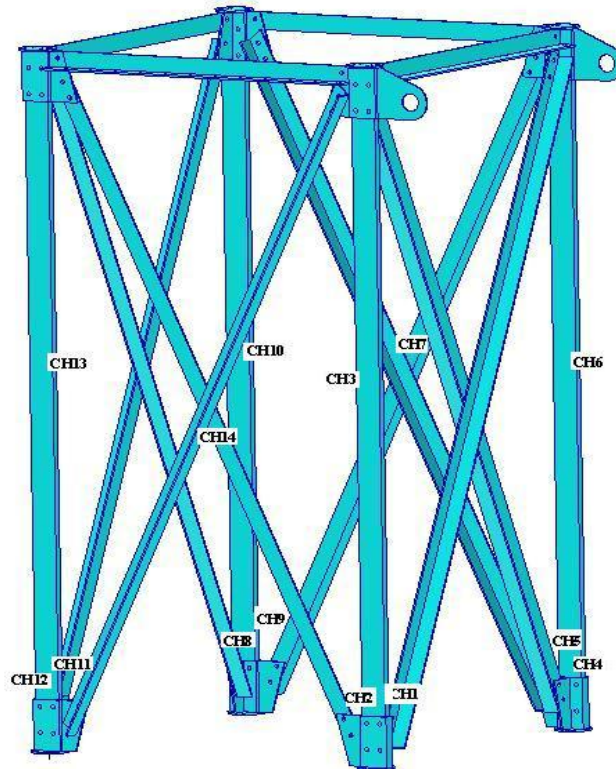

Fig 3.24b Schematic of strain gauge locations on the tower units/ sub assembly members



(a) Photograph of a typical strain gauge mounted on GE pultruded rod of cross arm



(b)

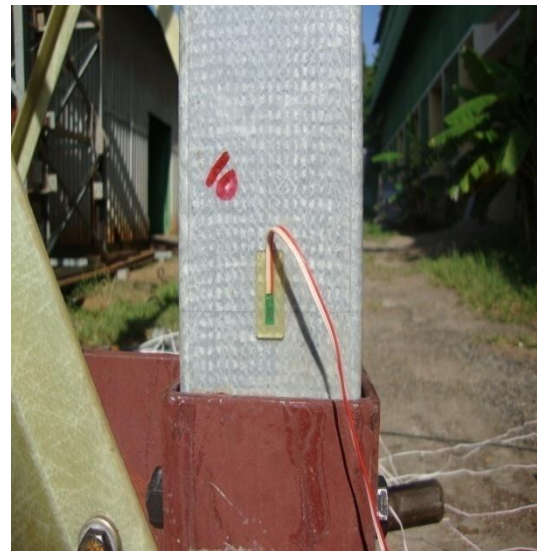

(c)

Figure 3.25 Strain measurements on the tower unit/sub assembly with cross arm

(b) Photograph showing strain gauges mounted on leg member (TS2CA)

(c) Photograph showing strain gauges mounted on leg member (TS2CA)

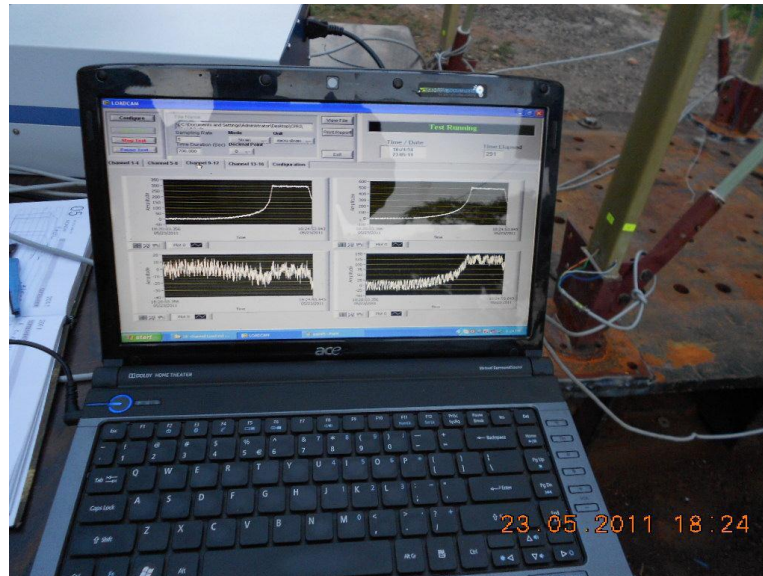

Fig.3.26 Output of strains in Lab View corresponding to loading

3.6 Construction and testing of full scale tower with composite members for mechanical performance

Subsequent to testing of cross arm and X-braced tower units/sub-assemblies, the study is extended to construct full scale tower with composite members and test. The tower consisting of square hollow composite leg members, angle bracing members and cross arm with solid circular composite members is constructed with gusset plates, end clamps and M12 bolts for connectivity. Details of various composite members used in the full scale tower are furnished in Table 3.4.

Table 3.4 GE Pultruded members used for composite tower

Sl. No	Sections	Sections	Size (mm)
1	Leg member	Square hollow section (two sizes)	101.6 x 101.6 x 6.35 / 101.6 x 101.6x 9.525
2	Bracing Horizontal	Equal angle section (two sizes)	76.2 x 76.2 x 6.35 / 50 x 50 x 6
3	Cross arm	Circular rod	Ø33

Different members listed in the table above are connected through plates and fasteners to construct the tower. Figure 3.27 shows the photograph of (a) a portion of the tower with members identified, (b) a closer view of the connection between members

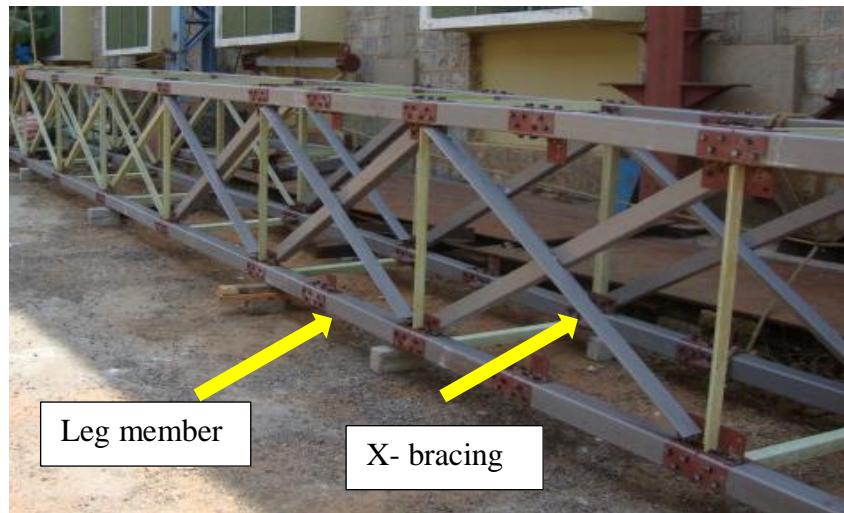

(a)



Square hollow leg member

(b)

MS Plate

Angle section X-bracing

Fig. 3.27 Photograph showing

- (a) Assembly of composite tower - leg member and bracing
- (b) Typical joint details of leg member and bracing

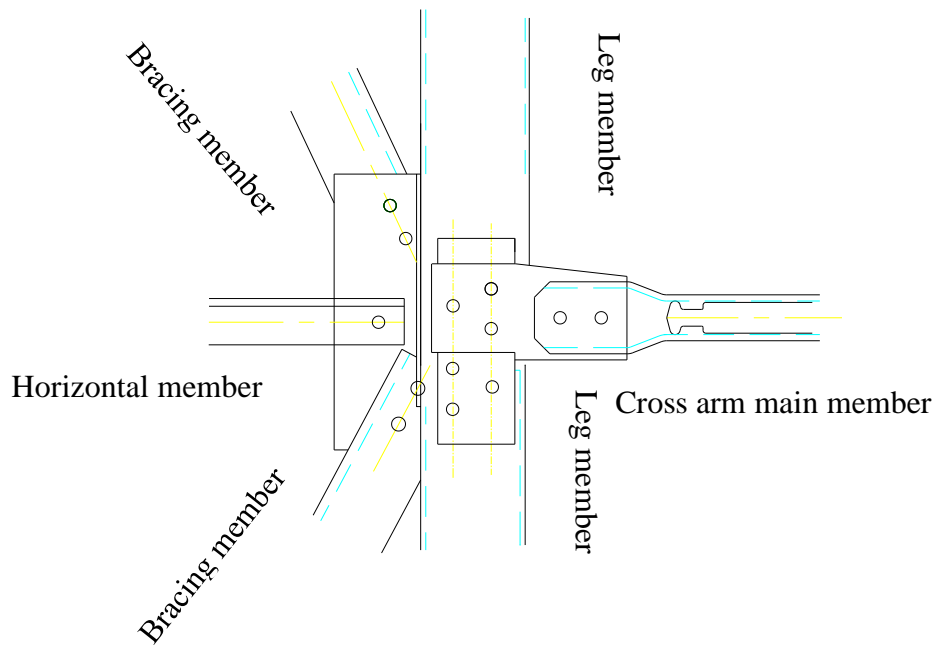

Fig 3.28a Schematic of a cross arm member joined to tower at leg member

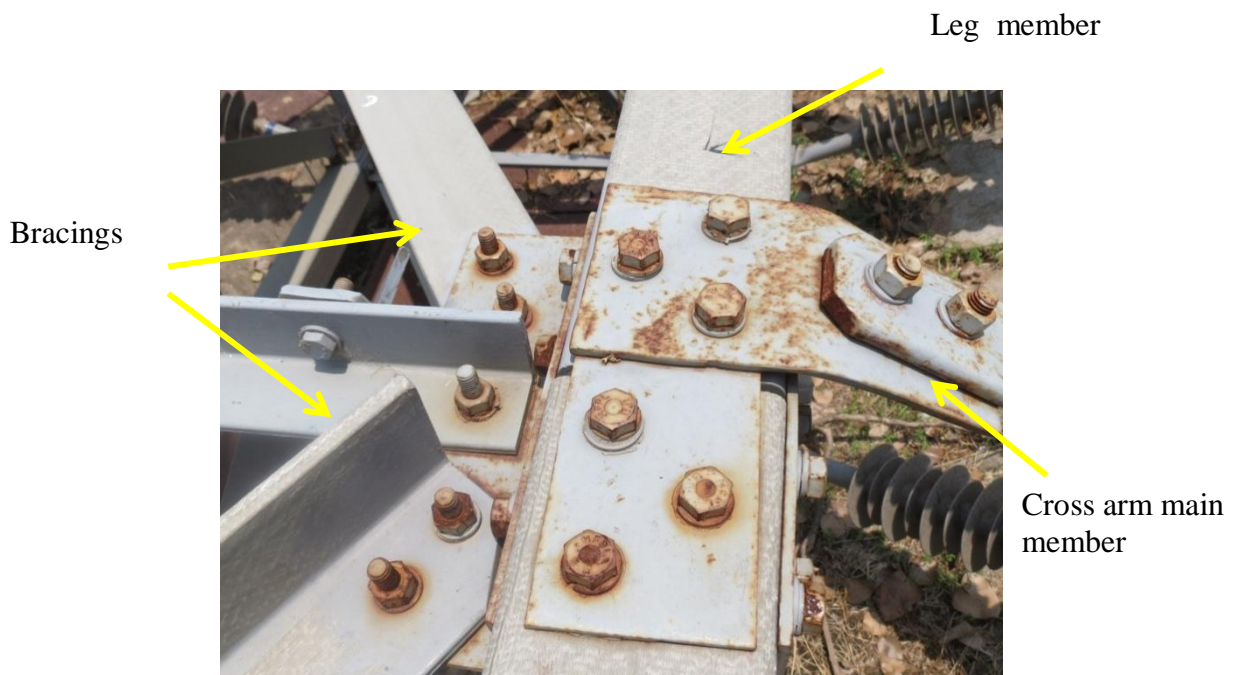

Fig 3.28 b Photograph showing the joining of cross arm member with leg members



Fig 3.29 Photographs showing details of (a) connection at the tip of cross assembly and (b) Connections at base portion of the cross arm



Fig 3.30 Photograph showing constructed full size (15 m) tower with composite members.

Figure 3.28 a and b along with Figure 3.29 a and b provide the details of attaching cross arm assembly to the tower. The tower with composite leg members, bracings and six cross arm assemblies with composite members is constructed. Figure 3.30 shows the constructed full size (15 m) tower with composite members.

Table 3.5 Total weight of full scale tower with composite members

Member description	Size	Length mm	Unit weight kg/m	No. of members	Total Kg
Leg members	101.6x101.6x9.52	1738	08	3.65	50.75
	101.6x101.6x6.35	1488	20	2.47	73.51
	101.6x101.6x6.35	666	08	2.47	13.16
	101.6x101.6x6.35	822	08	2.47	16.24
	101.6x 101.6x6.35	735	04	2.47	7.26
Bracing members	50x50x6	821	24	1.30	25.62
	50x50x6	928	24	1.30	28.95
	50x50x6	1845	08	1.30	19.19
	50x50x6	1893	08	1.30	19.69
	50x50x6	1622	12	1.30	25.30
	50x50x6	1677	12	1.30	26.16
	50x50x6	1677	04	1.30	8.72
	50x50x6	1715	04	1.30	8.92
	76x76x6.35	1622	12	1.84	35.81
	76x76x6.35	1677	12	1.84	5.38
	50x50x6	1034	04	1.30	5.38
	50x50x6	1119	04	1.30	5.82
	76x76x6.35	1670	04	1.84	12.29
	Cross arm	Φ33	876	12	1.8
Φ33		985	12	1.8	21.28
	Total weight of composite members				490 kg
	Weight of steel plates, sleeves,bolts / nuts etc.				300 kg
	Total weight of tower with composite members				790 kg

3.7 Testing of full scale tower with composite members

Design of transmission line tower is a highly complicated and to ensure the reliable performance of a particular design, physical proto type testing is indispensable. Thus a prototype of tower with composite members is constructed as explained in the earlier section. Subsequently it is tested for loading suggested in qualifying standards. The full scale tower is erected vertically on rigid footings at the Tower Testing Station of Central Power Research Institute, Bangalore (Figure 3.31). Loads are applied through haulage steel wire rope attachments are represented in schematic of Figure 3.32. Standard loads in three directions transverse, vertical and longitudinal are applied gradually without jerks through the electrically operated winches as shown in Figure 3.33. These loads are measured using calibrated load cells.



Fig. 3.31 Photograph showing tower mounted on rigid footings in testing station

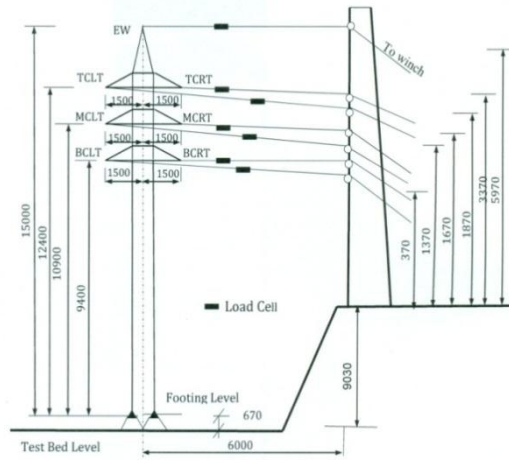

(a) Transverse

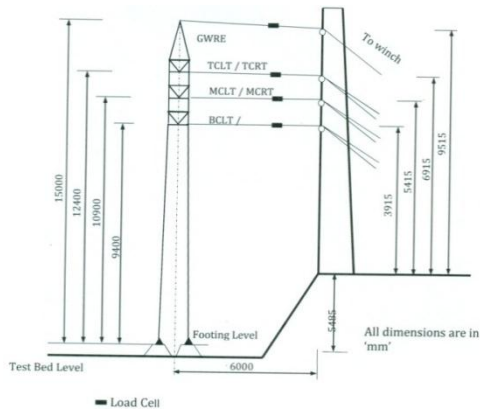

(b) Longitudinal

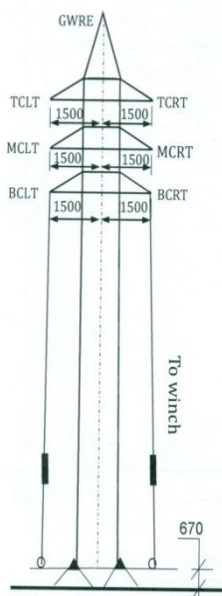

(c) Vertical

Fig 3.32 Loading arrangement in three direction

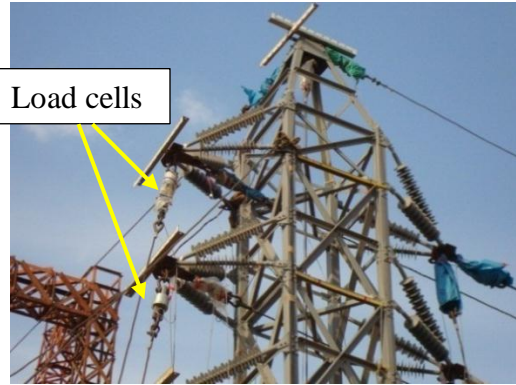

Fig 3.33 Photograph showing the tower and the loading arrangements

The calibrated load cells shown in Figure 3.34a are attached at required positions as shown in Figure 3.34b. The electrically operated loading winches shown in Figure 3.34c are controlled by a centralized control panel shown in Figure 3.34d in the control room for applying loads at different points of tower structure.



(a) Photograph showing stack of calibrated load cells



(b) Photograph showing load cells attached



(c) Photograph showing loading winches



(d) Photograph showing the control panel

Fig.3.34 (a-d) Details of tower testing

3.7.1 Procedure of testing full scale tower with composite members

The prototype tower with composite members is erected on the test bed and all the arrangements for applying loads are made. The tower is examined carefully to check whether all the bolts and nuts are tightened properly. The tower is made truly plumb (vertical) and square. All its members are checked for any visible defects. Two graduated scales are fixed at tip of tower peak to measure longitudinal and transverse deflection (see Figure 3.35). Three other scales are fixed on the tower body at cross arm bases as shown in Figure 3.35 to measure transverse deflection of the tower. Three scales are fixed at the tips of three cross arms on one side to measure longitudinal deflections. Deflection readings on these scales with reference to the plumb line are observed using optical theodolite of least count 5 mm.

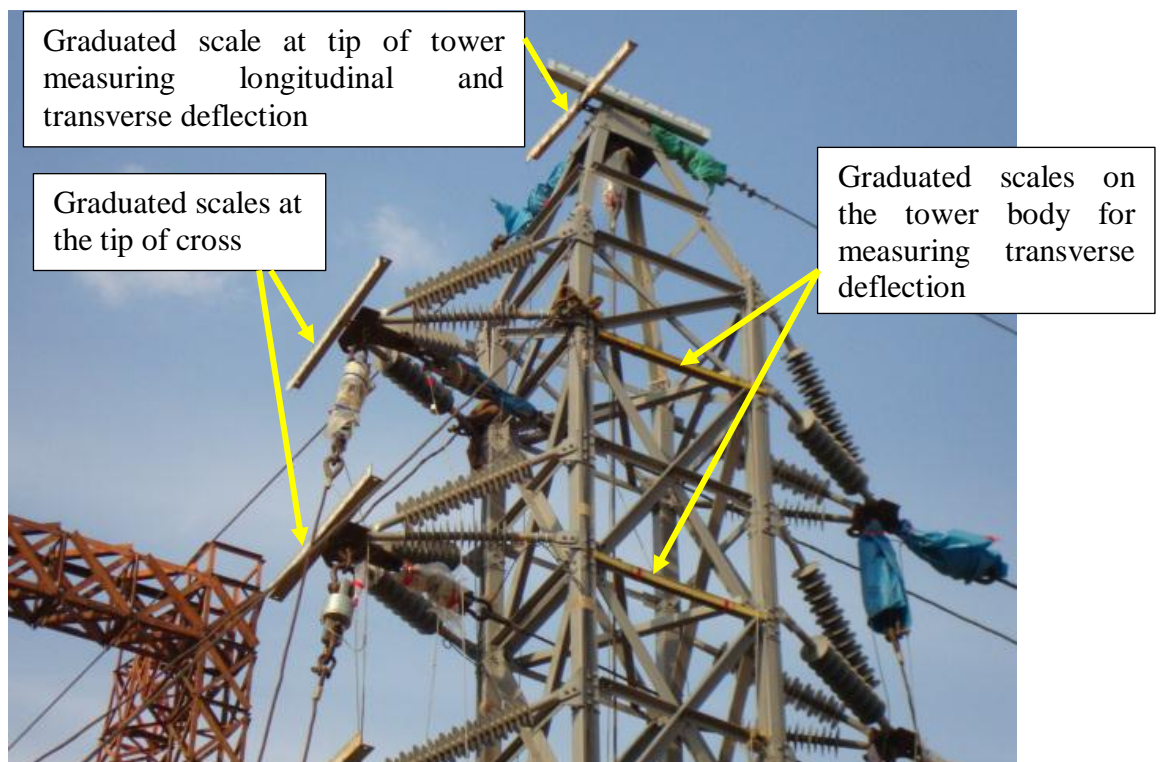
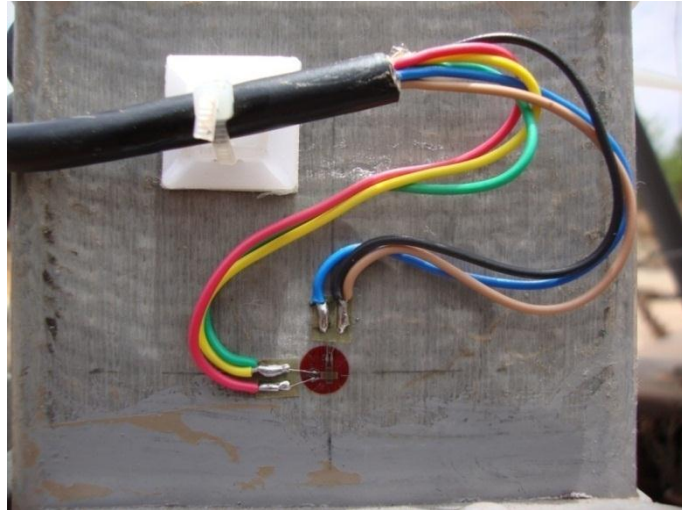

Fig.3.35 Photograph showing graduated scales fixed at the tip of tower and cross arms

To measure strains due to load application in composite members of tower, three rosette strain gauges are mounted at the critical places on members as shown in Figure 3.36 a and b.



(a)



(b)

Fig 3.36 Three rosette strain gauges mounted for strain measurement during testing

(a) Near the bottom of leg member (b) Near the base of cross arm member

As suggested in IS: 802, testing is to be carried out in three conditions

- (a) Reliability condition (Normal condition)
- (b) Security condition (Broken wire)
- (c) Safety condition (Maintenance)

Nature of loads, their full load magnitudes under these conditions is explained in chapter 2 (Table 2.3 and loading tree 2.6). The summary of loading sequence is provided in Table 3.6. Initially before the actual testing a Bolt take up test is done as explained next. All transverse and vertical loads are increased gradually and simultaneously up to 50 % of full load suggested for reliability condition (IS: 802 (Part 1/ Sec 1)). They are maintained for two minutes (Table 3.6) before the loads are gradually drawn to zero. The transverse deflection at the tip is measured at this stage. Any deflection recorded with respect to plumb position could be permanent deflection of the tower and is to be considered as the initial reading for subsequent purposes. Actual testing is commenced after this and is carried out in three phases. The strain measurements are carried out through 48 channel MCE 1000 DAQ system in these tests. The strain variations with respect to magnitude of applied loads are continuously recorded through the system.

Table 3.6 Tower testing loading sequence IS: 802 (Part 3)

Sl. No	Description of test	% loading of full load (loading tree in chapter 2)			Waiting period (sec)
		V	T	L	
1	Reliability condition	V	T	L	
		50	50	-	120
		75	75	-	120
		90	90	-	120
		95	95	-	120
		100	100	-	300
2	Security condition, Earth wire broken condition				
		100	50	50	120
		100	75	75	120
		100	90	90	120
		100	95	95	120
		100	100	100	300
3	Security condition, Top conductor broken condition				
		100	50	50	120
		100	75	75	120
		100	90	90	120
		100	95	95	120
		100	100	100	300
4	Security condition, Middle conductor broken condition				
		100	50	50	120
		100	75	75	120
		100	90	90	120
		100	95	95	120
		100	100	100	300
5	Security condition, Bottom conductor broken condition				
		100	50	50	120
		100	75	75	120
		100	90	90	120
		100	95	95	120
		100	100	100	300
6	Safety condition	50	100	-	120
		75	100	-	120
		90	100	-	120
		95	100	-	120
		100	100	-	300

3.7.2 Testing for reliability condition

As suggested in the standard IS: 802(Part 3) and repeated in Table 3.6 for this condition, vertical and transverse loads are applied at steps of 50%, 75%, 90%, 95% & 100% of full load. These loads are applied simultaneously at seven points, six cross arm tips and one at tower tip. The application period of two minutes suggested in the standard (Table 3.6) is maintained at each loading step. The loads at 100% full load is maintained for five minutes (Table 3.6). During the entire duration of load testing, the tower is closely observed for any visible signs of failure. If the tower sustains the above test without any such sign of failure, then the tower is deemed to be qualified for service.

3.7.3 Testing for security conditions

To test the tower for requirement under this condition, loads are maintained as suggested in sr. no. 2 to 5 of table 3.6 and loading tree in chapter 2. Vertical loads are initially increased to 100% of full load and then transverse and longitudinal loads are increased through steps of 50%, 75%, 90% and 95% of full load. At each step, the loads are maintained for two minutes and the deflections are noted. All loads are increased to 100% and maintained for 5 minutes and the deflections are noted. As per the standard IS: 802 (Part3) the tower is required to withstand these loads without showing any visible failure. To end the test, loads are gradually drawn off.

3.7.4 Testing for safety conditions

To test the tower for requirement under this condition loads are maintained as suggested in sr. no. 6 of Table 3.6 and loading tree in chapter 2. Transverse loads are initially increased to 100% of full load and then vertical loads are increased through steps of 50%, 75%, 90% and 95% of full load. At each step the loads are maintained for two minutes and the deflections are noted. All loads are increased to 100% and maintained for 5 minutes during which deflections are noted. As per the standard IS: 802 (Part 3) the tower is required to withstand these loads without showing any visible failure. To end the test, loads are gradually drawn off and deflections are noted subsequent to that.

3.8 Testing of cross arm and tower with composite members for electrical insulation and flash over

Generally, the design of tower encourages use of external insulation against flashover due to dielectric breakdown. The external insulation comprises of air and solid insulator strings consisting of disc insulators made of ceramic materials in the conventional metallic towers. In the present case of tower with composite members, the material of the cross arm acts as insulator and hence extra string insulators are not required. In the proposed tower, cross arm serves dual role of solid insulation to the tower body and support of the power conductor. The electrical insulation of tower is governed by steady state operating voltage and various events occurring in the system like energisation, re-energisation, faults and lightning etc. As recommended in the standard IS:2165 (Part 2) -1983 towers of lines up to 220 kV rating are tested for highest power frequency voltage and lightning impulse voltage and these should be greater than the values suggested in the above standard.

The tower is also tested for voltage flashover between conductor and the earthed metal part of the tower. This voltage recorded need to be greater than that suggested in the standard IS: 2071(Part 2): 1974. The tower needs to be tested in dry and wet conditions for flashover that occur during lightning.

The test for insulation and flashover suggested in the standard IS:2165 (Part 1) : 1977 RA 2006 phase to earth insulation coordination and IS:2165 (Part 2) :1983 RA 2006 phase to phase insulation coordination as per the rating are

- a. Power frequency tests (short duration 1 minute under wet condition)
- b. Lightning impulse tests

The performance under power frequency test is conducted in wet condition by applying high voltage for one minute duration. The power frequency test voltage is specified as the rms value of the voltage which the insulation is capable of withstanding for one minute. For lightning impulse test, it is recommended that a standard voltage to be applied at a very short duration for 15 +ve and -ve cycles (IS:2071). The suggested minimum values for power frequency withstand voltage and lightning impulse withstand voltage as per IS : 2165 are furnished in Table 3.7. Figure 3.37 shows the arrangements for power frequency tests under wet condition.

The part (a) of the figure shows the voltage application system. Part (b) shows the test being conducted on cross arm with the tower sub assembly, and (c) the test for full tower.



(a) Alternating voltage test system

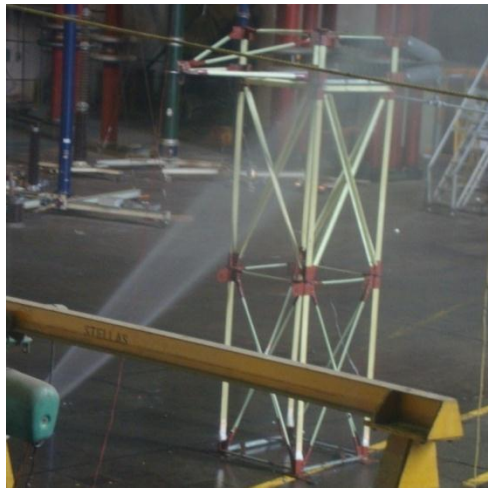

(b)

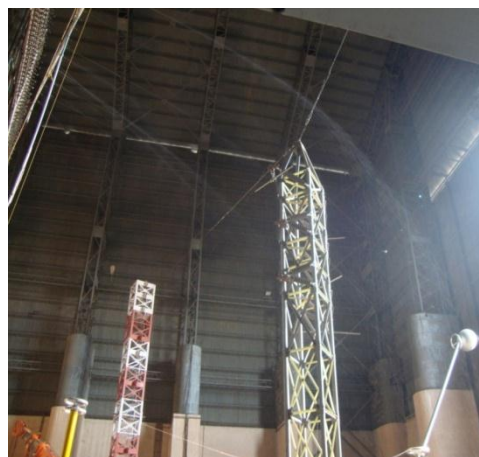

(c)

Fig. 3.37 Power frequency test

- (b) Photograph showing wet condition of cross arm with composite members
- (c) Photograph showing wet condition of full scale tower with six cross arms

Table.3.6 Suggested minimum values for power frequency withstand voltage and lightning impulse withstand voltage as per IS: 2165 (Part 2): 1983

Nominal voltage kV	Highest voltage for equipment kV	Rated lightning impulse withstand voltage kV	Rated power frequency short duration withstand voltage kV	Air clearance (mm)
66	72.5	325	140	630
132	145	650	275	1100
220	245	950	360	1900

The lightning impulse test is carried out in accordance with IS: 2071(Part2):1974 RA 2006. In this test, 15 standard impulses of positive and negative polarities each is applied. The standard lightning impulse is a full lightning impulse having a virtual front time of 1.2 μ s and a virtual time to half value of 50 μ s. It is described as a 1.2 / 50 impulse. Figure 3.38a shows the test set up and Figure 3.38 b&c shows the test arrangement for cross arm assembly and tower respectively.

The peak values of sustained voltage are obtained from the oscillograms recorded during the tests for cross arm in Figure 3.38 d and e and for full tower in Figure 3.38 f and g . The difference between specified value in the standard impulse and recorded one can be up to \pm 3% to meet the requirements of the standard. There cannot be more than two flash over occurring in the insulation in a test of 30 cycles.

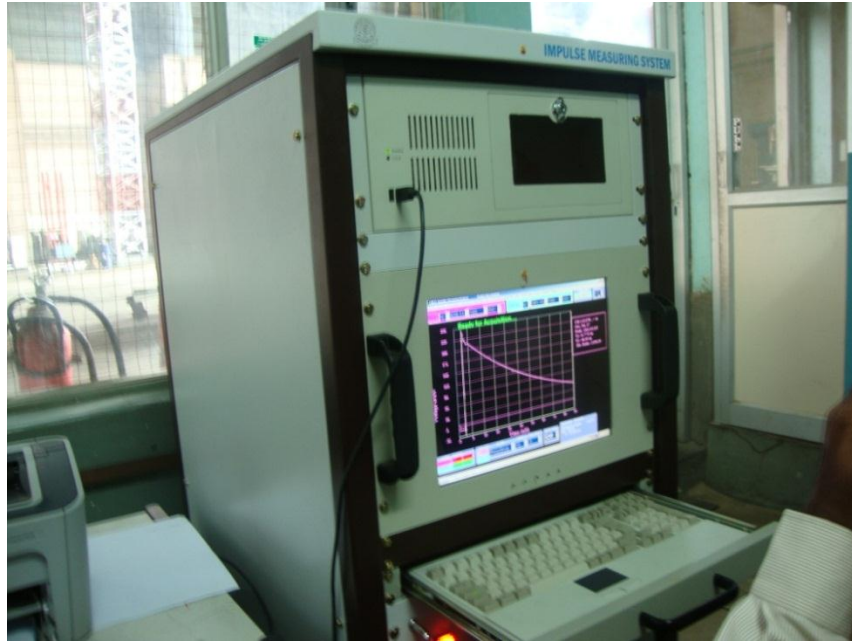

3.38 (a) Test set up

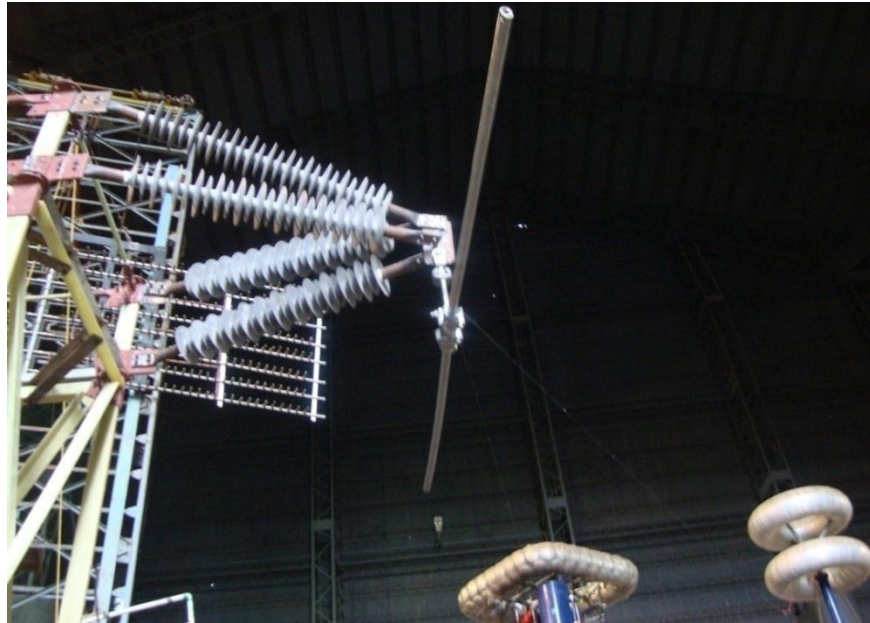

3.38 (b) Photograph showing live conductor attached to the cross arm with composite member with tower sub assembly



Fig 3.38 (c) Photograph showing live conductor attached to the cross arm with composite member with 15 m tower

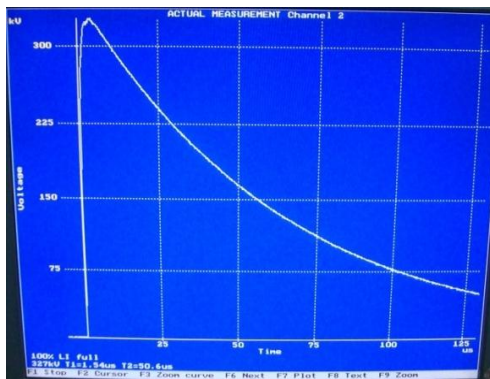

(d) Snap shot of lightning impulse voltage/time curve (+ve polarity) for cross arm



(e) Snap shot of lightning impulse voltage/time curve (-ve polarity) for cross arm

Fig. 3.38 Impulse voltage test

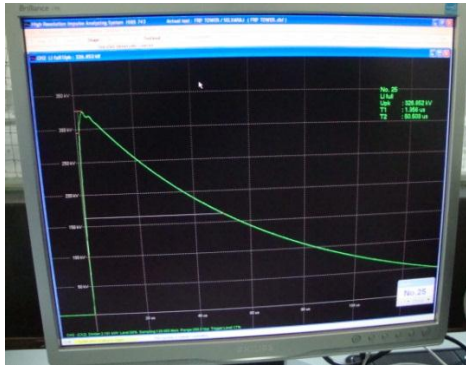

(f) Snap shot of lightning impulse voltage/time curve (+ve polarity) for full tower with cross arm

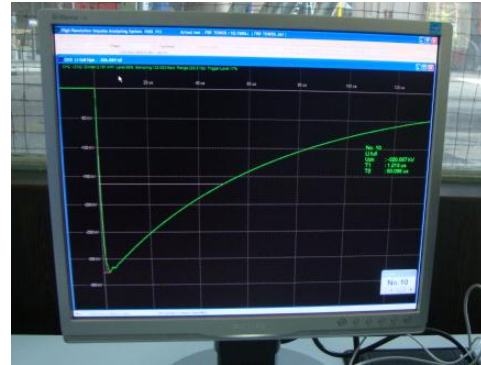

(g) Snap shot of lightning impulse voltage/time curve (-ve polarity) for full tower with cross arm

Fig. 3.38 Impulse voltage test

Initially, in the chapter, description of the procedure adapted for experimental determination of material properties is given followed by testing the composite members for cross arm and tower. A cross arm assembly is constructed from composite members and tested for sustaining mechanical loads. This is followed by description of tower sub assembly construction and testing. Ultimately, the full tower with all composite members is constructed and tested. Procedures for testing cross arm and the tower with composite members for necessary electrical insulation is also narrated in the last part of the chapter.

CHAPTER 4

4.0 RESULTS AND DISCUSSIONS

This section presents results of entire proposed work of analysis and testing a tower with composite members. Chapter begins with results of characterizing GE pultruded material for tower members. Results of testing of cross arm, tower units/ sub assembly and full tower made of pultruded composite members envisaged and elaborately discussed earlier are presented. In the first part, results of testing standard coupons of GE pultruded material are provided followed by results of testing actual tower members of pultruded material. In the last part, results of testing cross arm, tower units/sub assembly and full tower for mechanical and electrical loads are presented.

4.1 Results of testing GE pultruded material

Test coupons as per ASTM standards are cut out from the pultruded material and tested with process described in chapter.3. The coupons are tested for physical, mechanical and electrical properties as per the test procedures mentioned earlier. Density and percentage of water absorption are physical properties investigated for GE pultruded members to assess their suitability in towers. Results of these are presented below. Table 4.1 shows the average density and % water absorption determined from experiments and could be observed that these values are within the recommended range.

Table.4.1 Results of test for density and percentage of water absorption

	Tested values	Manufacturers values	Recommended values
Density (g/cm^3)	1.90	2.17	2.10 ± 1
Water absorption (%)	0.035	0.03	0.20

The standard coupons of GE pultruded composite material are cut out and tested for strength and modulus as outlined in chapter 3. The tensile strength and modulus for each sample is computed from the stress strain curve (Figure 4.1) obtained during test. As could be seen from the graph in Figure 4.1, the slope of stress – strain curve is

almost linear as expected up to failure. The tensile strength along with other parameters determined for GE pultruded material are presented in Table 4.2.

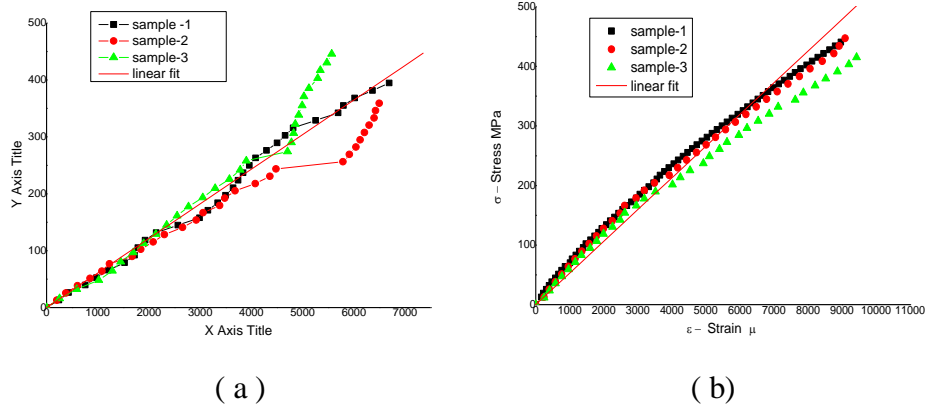

Fig.4.1 Typical longitudinal stress versus strain graph for pultruded members of
(a) Rectangle section (b) Circular section

Table.4.2 Results of tensile test and other computed properties of
GE pultruded material

Sample No	Breaking load kN	Tensile strength σ_t MPa	E_{11} MPa	E_{12} MPa	Poisson's ratio ν	G_{12} MPa
S-1	62	795	58995	19665	0.30	9835
S-2	63	808	55244	18415	0.46	9210
S-3	66	846	52041	17347	0.33	8675
S-4	68	666	58565	19525	0.38	9765
S-5	67	656	55105	18370	0.40	9185
S-6	64	656	54810	18270	0.38	9135
Average	65	738	55793	18599	0.38	9301

S1-S3 : Samples of rectangle cross section S4 - S6 : Samples of circular section

The average tensile strength of GE pultruded material is 738MPa and average modulus is 55793 MPa. Typical modes of failures in samples are shown in Figure 4.2 and are as expected.



(a). Samples of rectangle section



(b). Samples of circular section

Fig.4.2 Typical failures modes

The standard coupons of GE pultruded material are subjected to compression test also as discussed in chapter 3. The compressive strength of the GE pultruded material is determined experimentally and details are presented in Table4.3. From the Table it could be observed that the average compressive strength of GE pultruded material is about 283 MPa. Typical modes of failures of test coupons under compression are shown in Figure 4.3 and are as expected.

Table.4.3 Results of compression test

Sample No	Width mm	Breadth mm	Height mm	Breaking load N	Compressive strength σ_c MPa
S-1	12.20	12.20	25.12	42160	283.3
S-2	12.20	12.20	25.11	44000	295.6
S-3	12.20	12.20	25.13	43300	268.5
Average	12.20	12.20	25.12	43153	282.5



Fig.4.3 Typical failure modes in compression test

GE pultruded samples are tested under flexure also as explained in chapter 3. The flexural strength of the GE pultruded material and other properties computed are presented in Table 4.4. Here, it could be observed that the average flexural strength is about 770MPa. Typical failure modes of test coupons in flexure are shown in Figure 4.5

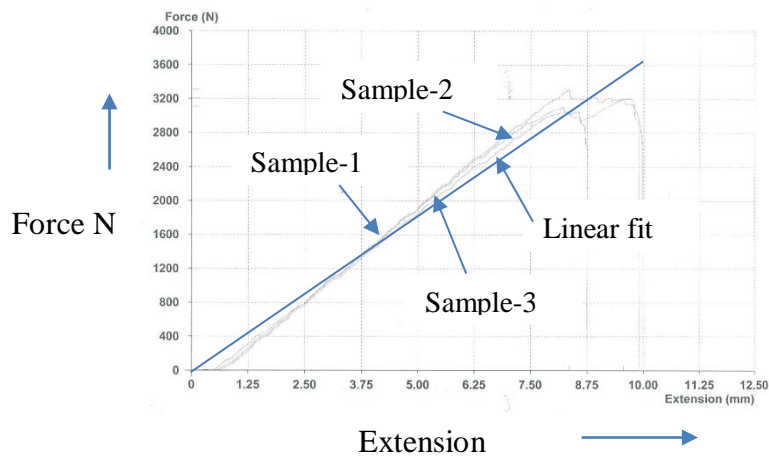

Fig.4.4 Flexural load versus displacement plots obtained during flexural test

Table.4.4 Results of flexural test

Sample No	Width mm	Thickness mm	Length mm	Breaking load N	Flexural strength σ_{fs} MPa
S-1	15.08	6.30	100	3112	780
S-2	15.16	6.30	100	3012	755
S-3	15.07	6.30	100	3104	778
Average	15.10	6.30	100	3076	770



Fig.4.5(b).Photograph showing typical failure observed in flexural test of GE pultruded samples

GE pultruded samples are tested under accelerated weathering test for coated and non-coated samples as explained in chapter 3. Table 4.5 list the changes in physical parameters during accelerated weathering test. It can be observed here that the percentage of weight loss due to weathering is less than 1 % for both coated and non-coated specimens and no significant dimensional change is observed.

Table 4.5 Test results of accelerated weathering test

Parameters	Coated samples		Non coated samples		% difference
	Before	After	Before	After	
Length (mm)	203	203	203	203	No change
Width (mm)	19.10	18.97	19.08	18.97	0.1
Thickness (mm)	6.30	6.27	6.34	6.31	0.1
Gauge length (mm)	50.11	50.11	50.80	50.80	No change
Gauge width (mm)	14.78	14.70	14.66	14.62	0.27
Weight (g)	42.09	41.97	43.19	43.13	0.14

Table 4.6 furnishes the details of tensile test done for GE pultruded samples before and after accelerated weathering/ageing, It can be observed here that the loss of tensile strength due to accelerated weathering is less than 3 %.

Table.4.6 Loss of tensile strength results due to accelerated weathering

Sr. No.	Sample	Tensile strength σ_t MPa		
		Before Ageing	After Ageing	% loss
1	Solid rectangle section	812	795	2.1
2	Angle section	752	733	2.5
3	Hollow square section	792	769	2.9

GE pultruded samples are tested for erosion test as explained in chapter 3. Table 4.7 shows the percentage of weight loss from the erosion test. It can be observed from this table that the erosion properties are found to be less affected by accelerated weathering and also observed that the percentage of weight loss is more in the case of 90⁰ jet angle than 45⁰ jet.

Table 4.7 Results of erosion test before and after weathering

	Angle of jet (degrees)	Initial weight (g)	Final weight (g)	% weight loss
Before ageing	45	17.5667	17.5345	3.0
	90	17.4326	17.3739	6.0
After ageing	45	16.9029	16.8714	3.0
	90	16.9054	16.8501	6.0

GE pultruded samples are tested for di-electric strength as discussed in chapter.3. the test results are presented in Table 4.8. It could be observed that, the dielectric breakdown test resulted in an average dielectric strength of 37.74 kV / mm which is 30-35 % more than the recommended value of 25 kV / mm.

Table 4.8 Results of di-electric strength test on GE pultruded members

Sr. No.	Length mm	Breadth mm	Thickness mm	Tested Voltage kV/mm	Recommended value kV/mm (ASTM D149)
1.	149.82	39.22	3.05	36.95	25
2.	149.94	39.23	3.08	37.45	25
3.	149.91	39.13	3.06	38.81	25
Average	148.89	39.19	3.06	37.74	25

Thus all tests carried out in the above study on material coupons indicate the suitability for members in power transmission line towers.

4.2 Results of testing of tower member

Experimental testing of tower members in actual size is carried out for evaluation of their suitability through mechanical properties in tension, compression and flexure. Members with three different cross sections are used in this study like solid rectangle, solid circular and hollow square. Results of testing for their load carrying capacity are presented in Table 4.9. It can be observed that the load carrying capacity of members in tension is between 145 – 180 kN, under compression 135 -170 kN and under flexural 135 – 155 kN.

Table 4.9 Load carrying capacity of tower members determined from tests

Sr. No.	Sample	Average breaking loads (kN)		
		Tension	Compression	Flexural
1.	Solid rectangle section	180	170	155
2.	Hollow square section	150	165	140
3.	Solid circular section	145	135	135

4.3 Results of testing end clamps of cross arm members

Two types of attachment for end clamps are considered viz., adhesive bonding with epoxy glue and crimping process. The bonding strength of metallic end clamps is determined under tensile load using 200 kN hydraulic loading device. The test results are presented in Table 4.10. Figure 4.6 presents the load versus strain curves for this test, it could be noticed that the rods with crimped ends exhibit higher bonding strength than adhesive bonding. End clamps fitted with adhesive bonding slipped out early in the testing. The strength of crimped joint is about 140 kN whereas with adhesive joint strength is only 90 kN, the crimped joint strength are 35 % higher than adhesive joints. Hence for further construction, members are fitted with metallic end clamps with crimping.

Table 4.10 Results of bonding strength test on cross arm member

Sr. No.	Load in N	Adhesive bonding method		Crimping method	
		Strain μ	Strain μ	Strain μ	Strain μ
1	500	250	260	222	195
2	1000	155	360	380	350
3	1500	300	520	470	450
4	2000	360	600	600	550
5	2500	450	700	750	650
6	3000	500	840	780	750
7	3500	600	970	850	850
8	4000	760	1100	900	870
9	4500	885	1220	1030	950
10	5000	990	1350	1230	1120
11	5500	1130	1490	1360	1180
12	6000	1290	1620	1490	1360
13	6500	1370	1760	1680	1450
14	7000	1490	1900	1800	1600
15	7500	1630	2040	1940	1650
16	8000	1760	2150	2000	1800
17	8500	1920	2300	2220	2000
18	9000	2000	2460	2330	2150
19	9500	-	-	2470	2300
20	10000	-	-	2550	2350
21	10500	-	-	2700	2400
22	11000	-	-	2950	2700
23	11500	-	-	2975	2800
24	12000	-	-	3225	2950
25	12500	-	-	3350	3000
26	13000	-	-	3450	3130
27	13500	-	-	3600	3350
28	14000	-	-	3750	3450

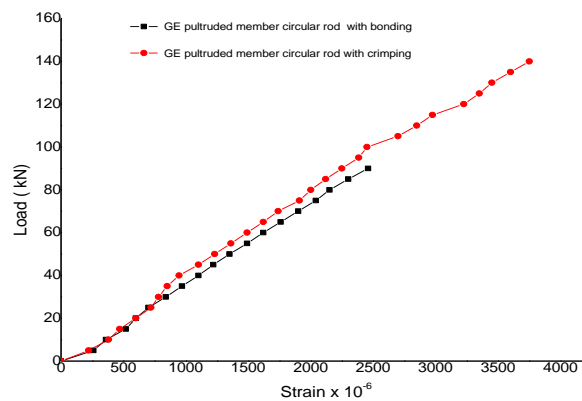

Fig 4.6 Load versus strain behavior with metallic clamps

4.4 Results of testing cross arm for mechanical performance

Initially the cross arm members are designed using method of section. The forces in the cross arm members are estimated under reliability and security conditions (Ref. loading tree 2.6). The maximum forces in the main member are 11290 N and in tie member 13513 N is determined. Based on the forces the required diameter of cross arm is $\varnothing 22$ mm. The standard diameter of $\varnothing 33$ mm is selected for further analysis. The finite element analysis of the cross arm with member diameter of $\varnothing 33$ mm is carried out as detailed in chapter 2 to estimate stresses and displacements of members under the application of standard loads (Ref loading tree 2.6). The pattern of stress distribution and displacement of the cross arm members are shown in Figure 4.7 for security condition (case 2). The main and tie members (M2 and T2) on longitudinal load side of the cross arm experiences maximum stress of about 197MPa and 72.7 mm displacement for the combined application of transverse, vertical and longitudinal loads as suggested for security condition.

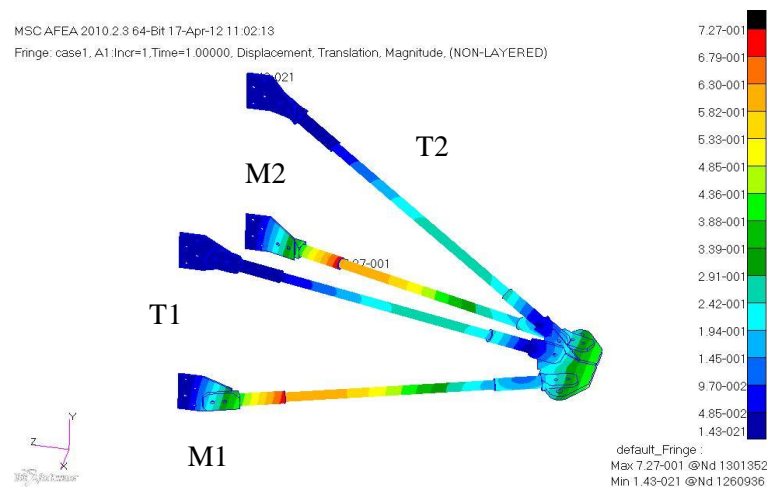

Fig. 4.7a Post processor plot showing maximum displacement of cross arm under combined transverse, vertical and longitudinal loads

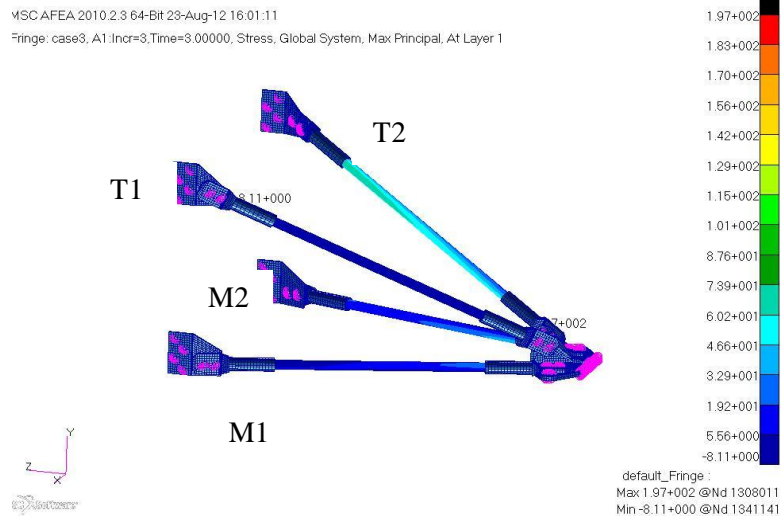

Fig. 4.7b Post processor plot showing maximum stresses in the cross arm members under combined transverse, vertical and longitudinal loads

The physical construction of cross arm is carried out. Test for mechanical performance of the cross arm assembly is carried out as discussed in chapter 3. These loads are applied in three directions at the tip of cross arm as per loading tree 2.6. The behavior of a cross arm is monitored by measuring the strains in the members.

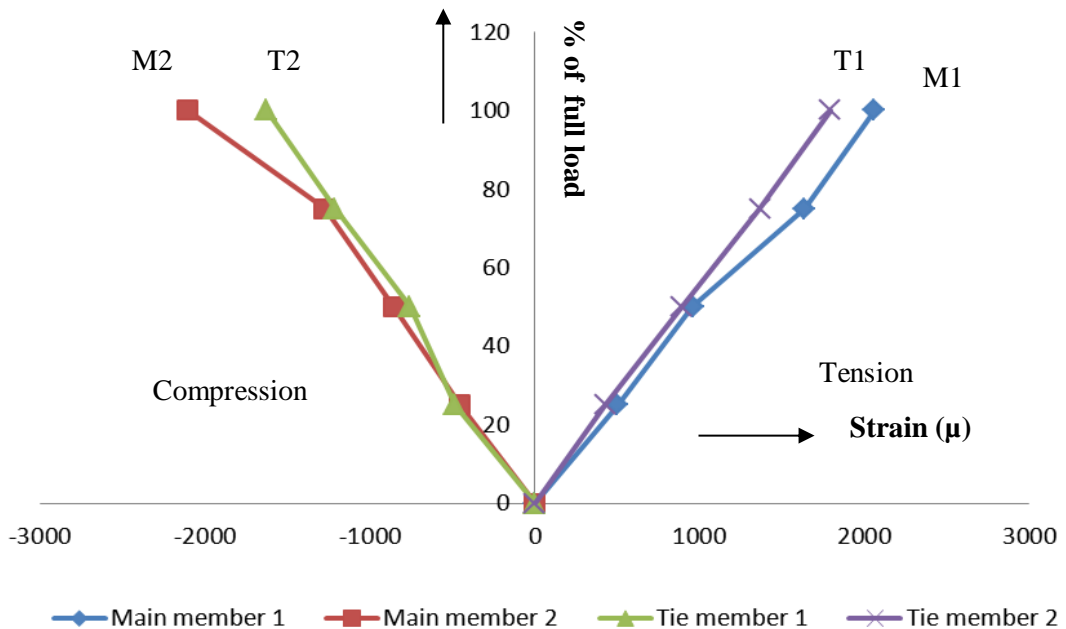

Fig. 4.8 Load versus strain behavior of cross arm members

The experimental strains are measured and are plotted against loads for different members shown in Figure 4.8. The deflections measured at the tip of cross arm under reliability and security conditions are presented in Table 4.11. The overall deflection at the tip of the cross arm measured from experiment is 43.75 mm on the longitudinal direction.

Table 4.11 Deflections measured from experiment at cross arm tip

Load (%)	Measured deflection at the tip of cross arm (mm)	
	Reliability condition (Transverse direction)	Security condition (Longitudinal direction)
50	10.25	14.15
75	11.00	20.05
90	11.25	34.15
95	11.50	39.00
100	11.75	43.75

Table 4.12 lists the factors of safety of cross arm members computed from analytical through method of section and FEA. It could be observed here that the maximum forces in cross arm main and tie members obtained from method of section and FE analysis are adequately comparable. FE analysis yields results little higher than the former method as the former one is only an approximate method. Both analyses yield a factors of safety higher than the recommended ones.

Table.4.12 Comparison of forces in cross arm members

Load case	Forces (N) determined in the cross arm members by			Factor of Safety		
	Method of section	FE Analysis	Ultimate load (Table 2.5)	Method of section	FE Analysis	Required as per standard
Case-1: Reliability condition	4267 (T)	4956 (T)	31580	7.40 (T)	6.37 (T)	3.0
	8167 (M)	9228 (M)		3.86 (M)	3.42 (M)	
Case-2: Security condition	13513 (T)	14184 (T)	31580	2.33 (T)	2.22 (T)	2.0
	11290 (M)	12070 (M)		2.79 (M)	2.62 (M)	

M : Main member T : Tie member

The maximum strains determined from the FE analysis are compared with measured strain shown in Table 4.13. The maximum strains obtained from experiment are comparable to those from FE analysis. The deviation is less than 15 % in most of the cases. It could be seen from the Figure 4.8 that the axial forces in the main members are linearly varying with applied load. The axial force in the tie members (T1 and T2) is found to be slightly lesser in magnitude than on the other members. And also stresses in two member are tensile in nature while as other two members are compression. The main member (M2) which is experiencing higher strain is prone to buckle.

Table 4.13 Comparison of experimental and FEA strains of cross arm members

Load Case	Member ID	Average strain (μ strain)		% Difference
		Measured	FE Analysis	
Case-1: Reliability condition	M1	400	321	19.75
	T1	569	472	17.04
	M2	683	575	15.81
	T2	549	459	16.39
Case-2: Security condition	M1	1267	1075	15.15
	T1	1476	1310	11.24
	M2	2105	1860	11.64
	T2	1859	1645	11.51

The composite cross arm successfully withstood with no visible sign of failure for the maximum loads of 2.48kN in vertical direction, 5.97kN in transverse and 21kN in longitudinal directions respectively. These loads are about 2.5 times of % full loads more than the required safety factor of 2.0 as suggested for security condition.

4.5 Results of testing tower units / sub assembly

The FE analysis of tower units for all three prototypes are considered for tower units prototype TS1: a tower sub assembly with solid rectangle leg members and solid circular rod bracing members, prototype TS2 2: a tower sub assembly with solid rectangle leg members and solid angle bracing members and prototype TS3 3: a tower sub assembly with hollow square leg member with solid angle bracing members as discussed in chapter 2. All these proto types are subjected to loading in FEA similar to service condition test. Figure 4.9, 4.10 and 4.11 presents the plots of three prototypes studied indicating the stresses and deformation at various locations.

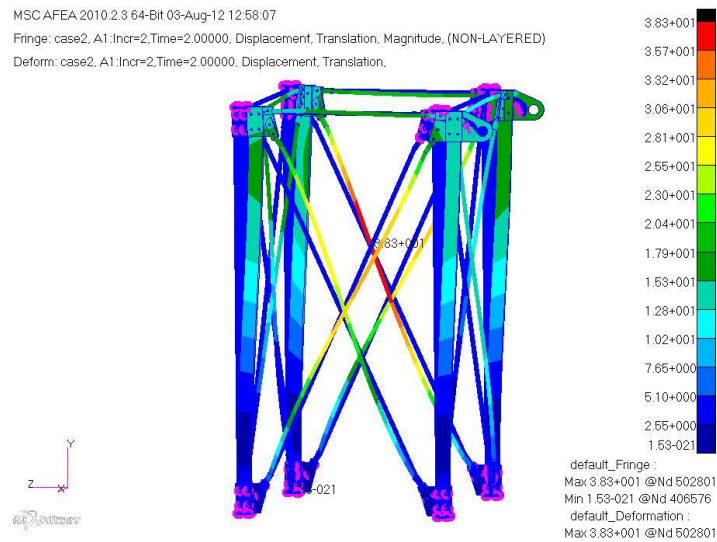

Fig.4.9a Maximum deformations in member of prototype TS1 (Table 2.23) using circular section bracing with solid rectangular leg member

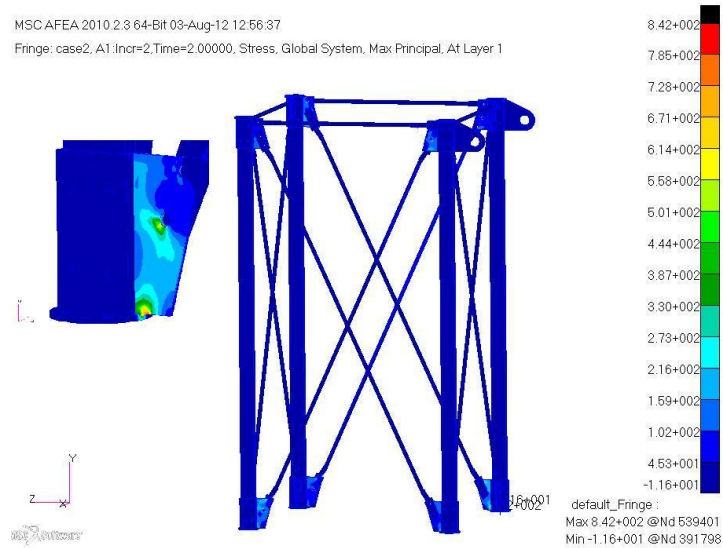

Fig. 4.9b Maximum stresses in members of prototype TS1 (Table2.23) using circular section bracing with solid rectangular leg member

As can be observed from the plots in Figure 4.9 a and b, the maximum deformation obtained at the top of the tower unit is 38.3 mm, and maximum stresses in the bracing member is 795MPa which is higher than the allowable stress of 283MPa. Thus, the bracing experiencing this stress could be failing under the load.

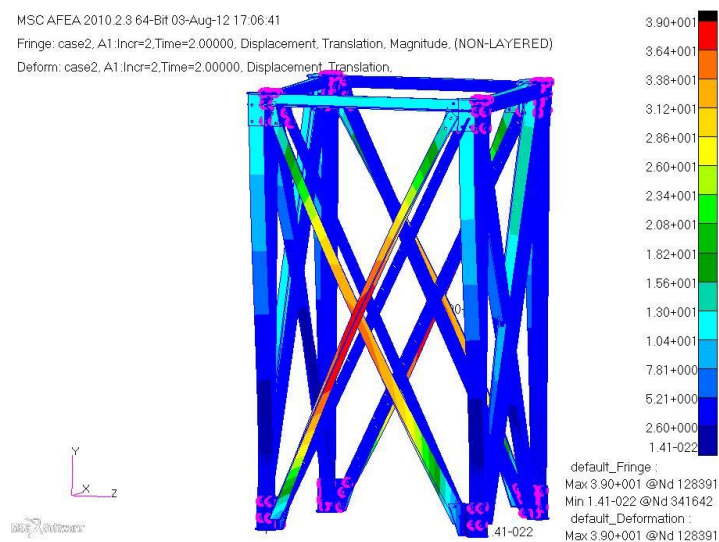

Fig. 4.10a Maximum deformations in member of prototype TS2 (Table 2.23) using angle section bracing with solid rectangular leg members

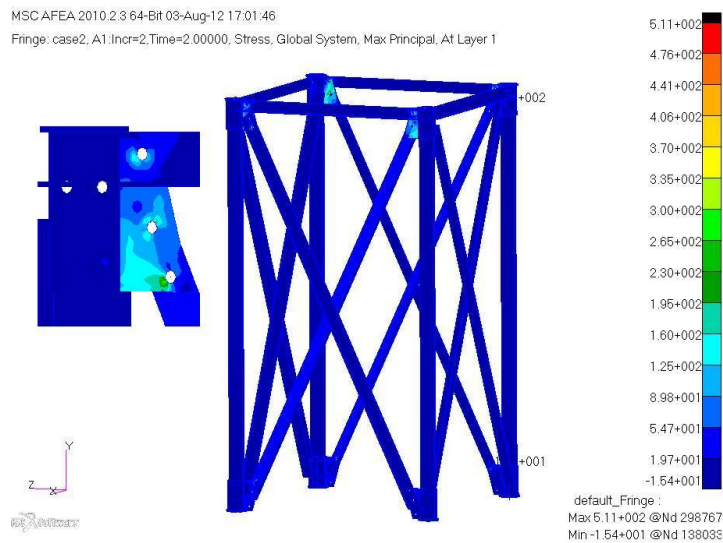

Fig. 4.10b Maximum stresses in member of model TS2 (Table 2.23) using angle section bracing with solid rectangular leg members

As can be observed from the plots in Figure 4.10 a and b, the maximum deformation obtained at the top of the tower unit is 39 mm, and maximum stresses in the bracing member is 230MPa which is lower than the allowable stress of 283MPa.

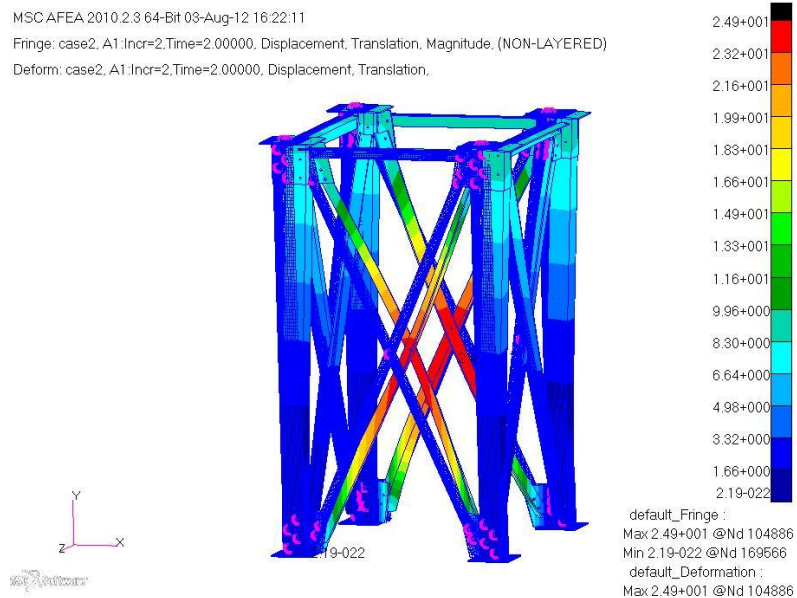

Fig. 4.11a Maximum deformations in member of prototype TS3 (Table 2.23) using angle section bracing with hollow square leg members

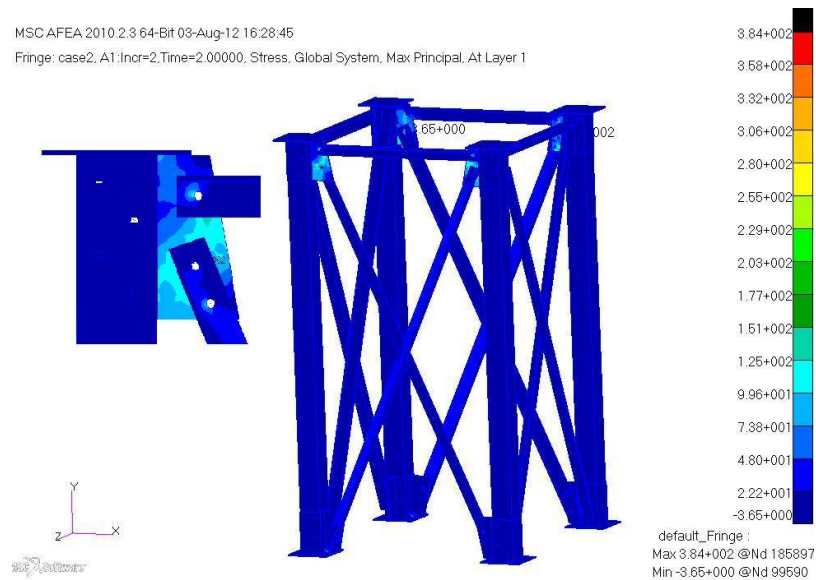

Fig. 4.11b Maximum stresses in member of prototype TS3 (Table 2.23) using angle section bracing with hollow square leg members

As can be observed from the plots in Figure 4.11 a and b, the maximum deformation obtained at the top of the tower unit is 24.9 mm, and maximum stresses in the bracing member is 100MPa which is lower than the allowable stress of 283MPa. The prototype TS3 records least stress and should be giving good factor of safety adopted.

The physical construction of three different prototype TS1,TS2 and TS3 is considered. The mechanical performance of all three prototype are carried out as discussed in chapter 3. The loads are applied in three directions at the top of tower as per loading tree 2.6. The behavior of a tower units are monitored by measuring the strains in the members. The experimental strains are measured and are plotted against loads for different members shown in Figure 4.12. The overall deflection at the top of the tower units measured from experiment for TS1 31.20 mm, TS2 34.15 mm and TS3 20.22 mm.

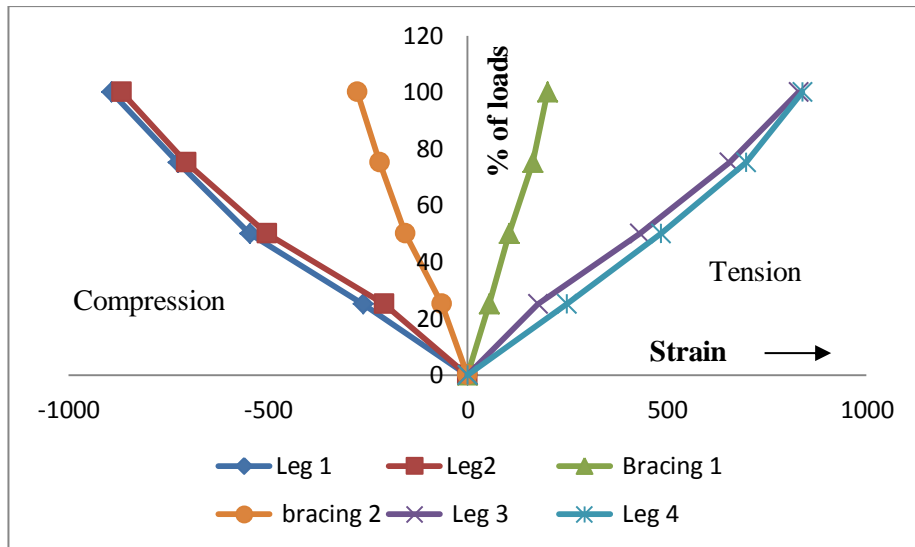

Fig.4.12a Load versus strain plot in different members of prototype TS1

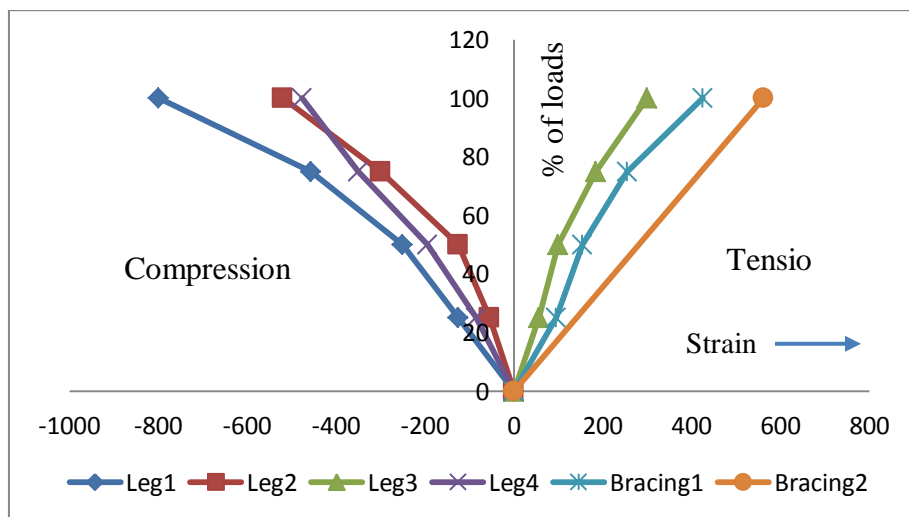

Fig.4.12b Load versus strain plot in different members of prototype TS2

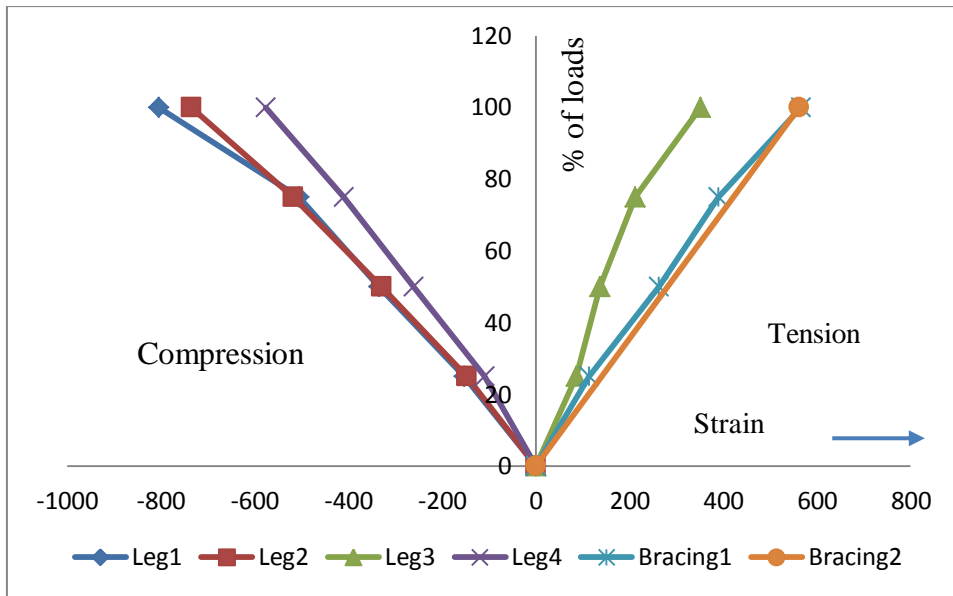

Fig.4.12c Load versus strain plot in different members of prototype TS3

Table 4.14 Comparison of experimental and FEA results

Proto type of tower sub assembly	Max. deflection at 100 % full load (mm)		Max. strain at the bottom of leg member (μ)	
	FEA	Experiment	FEA	Experiment
TS1	38.3	31.20	956	873
TS2	39.1	34.15	875	745
TS3	24.9	20.22	794	678

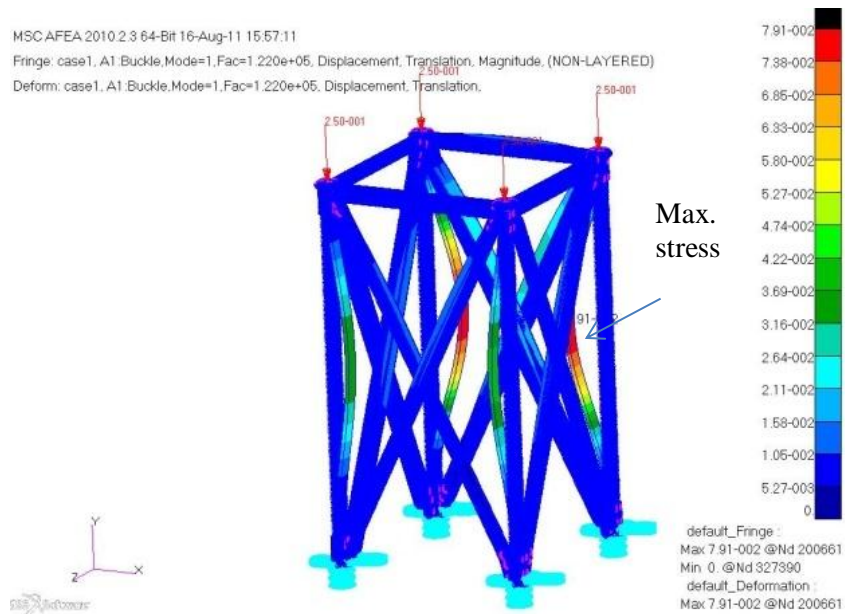

Fig.4.13 Buckling observed in leg and bracing member of prototype TS1 in FEA



Fig.4.14 Photograph showing buckling of leg and bracing of tower sub assembly prototype TS1 during testing

From strain plots for the three prototypes, it is found that bracings of prototype TS1 experience a maximum compressive strain (Figure 4.12 a, b and c) when compared to

others. Thus this bracing could be prone to failure, the deformations and strains obtained from FEA and experimental test are compared in Table 4.14. It can be seen that prototype TS3 of X-braced tower sub assembly using hollow section, the maximum stress and deformation are lesser compared to other one using solid sections. Prototype TS1 indicated failure of one of its bracings (bracing 1) which experienced maximum strain in compression (Figure 4.12a). The same is observed during FEA of prototype as explained in section 4.6. As observed in FEA, maximum stress occurred in bracings for buckling mode as shown in Figure 4.13. A similar situation is observed when the proto type TS1 is tested experimentally under buckling loads (Ref Fig 4.14). Thus prototype TS1 consisting solid rectangular C/s for bracing could not satisfy the performance requirements.

4.6 Results of testing tower units / sub assembly with cross arm mounted

As discussed in the earlier section, prototype TS1 experience excessive buckling in one of the bracings thus failing to meet requirements of IS:802. Hence TS2 and TS3 are continued for further analysis as well as physical testing with cross arm mounted. The FE analysis of two prototype tower units with cross arms TS2CA, TS3CA are carried out as discussed in chapter 2.

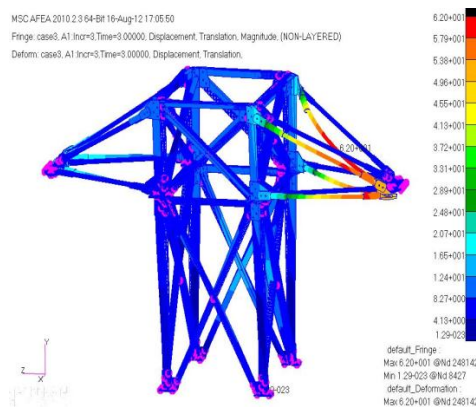

Fig. 4.15a Maximum deformations observed in members of prototype TS2CA tower unit with cross arm

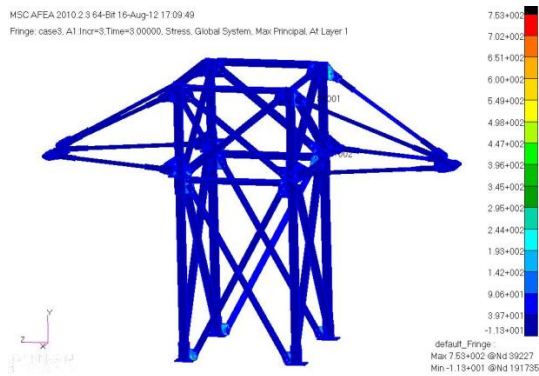

Fig. 4.15b Maximum stresses observed in the bracing members of prototype TS2CA tower unit with cross arm

Figure 4.15 a and b presents the deformations and stresses in the prototype TS2CA. The maximum deformation obtained at the tip of cross arm is 62 mm and maximum stresses at the bracing hole at the bottom joint is 345MPa which is higher than the allowable of 283MPa.

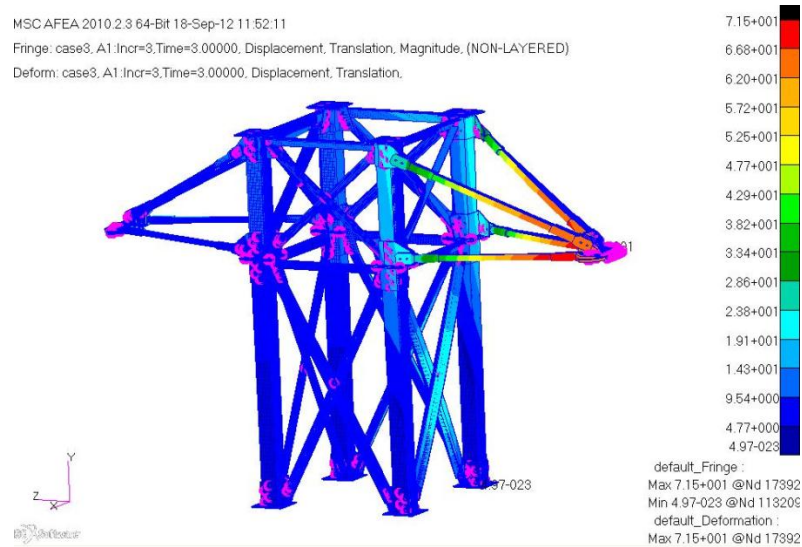

Fig. 4.16a Maximum deformations observed in members of prototype TS3CA tower unit with cross arm

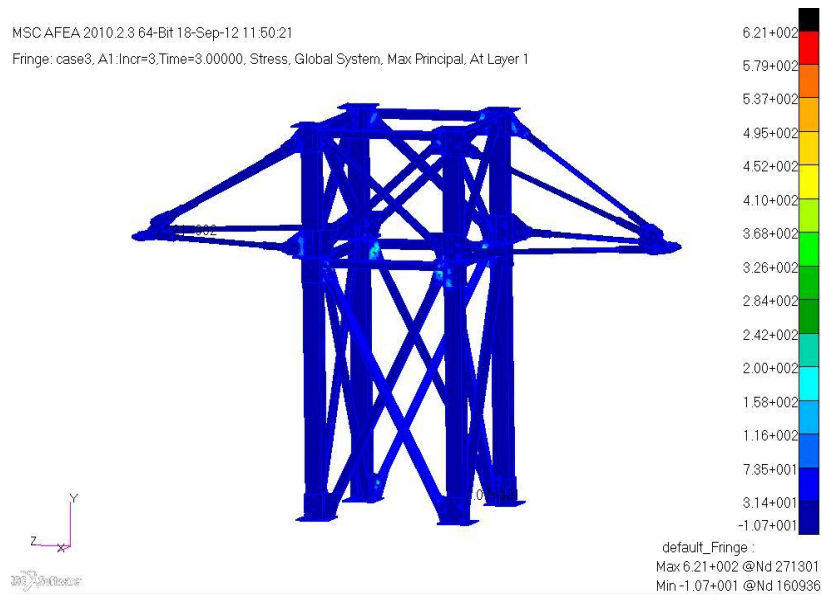

Fig. 4.16b Maximum stresses observed in the joints of bracing members prototype TS3CA tower unit with cross arm

Figure 4.16 presents the deformations and stresses in the prototype TS3CA. The maximum deformation obtained at the tip of cross arm is 71.5 mm and maximum stresses at the bracing hole at the bottom joint is 244MPa which is lower than the allowable of 283MPa.

The physical construction of two different prototypes TS2CA, TS3CA is considered. The mechanical performance of two prototypes is carried out as discussed in chapter 3. The loads are applied in three directions at the tip of cross arm as per loading tree 2.6. The behavior of tower units and cross arm members is monitored by measuring the strains in the members. The experimental strains are measured and are plotted against loads for different members shown in Figure 4.17.

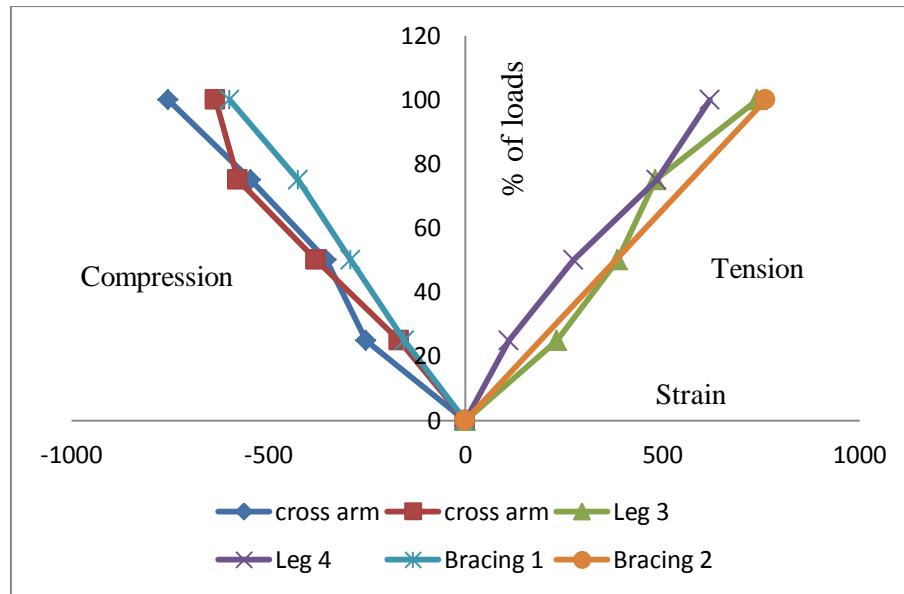

Fig.4.17 Load versus strain plot in different members of prototype TS2CA

Table.4.15 Comparison of experimental and FEA results

Prototype of tower sub assembly with cross arm	Max. deflection at tip of cross arm at 100 % load mm		Max. strain at the bottom of leg member (μ)	
	FEA	Experiment	FEA	Experiment
TS2CA	62.0	53.5	823	749
TS3CA	71.5	64.2	735	661

It can be observed from the Table 4.15, TS2CA the maximum strains obtained from the FE analysis and experiment are higher for TSC2A than those for TS3CA. During increasing of loads beyond suggested values, the bracing member at the bottom assembly in TS2CA (Figure 4.17 and 4.18) failed due to shear at bolt hole.

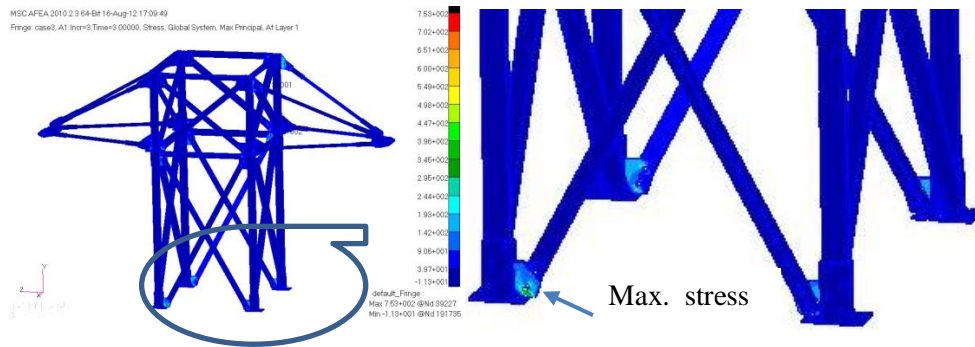

Fig. 4.17 Maximum stresses observed at the bolt hole at the bracing members prototype TS2CA tower unit with cross arm



Fig. 4.18b Photograph showing failure of bracing member at bolt hole(TS2CA)

The maximum shear stress in the bolted joint at failure 310MPa which exceeded the allowable strength 283MPa. Loads recorded at the instance of failure are 6.2kN transverse load, 2.6kN vertical load and 20kN longitudinal load. These loads are about 2.4 times suggested full loads implying safety factor of 2.0. The prototypes TS3CA of tower sub assembly with cross arm successfully withstood the maximum loads of 8.7kN transverse loads, 4.5kN vertical load and 32kN longitudinal load. These loads are about 3.5 times higher than the recommended loads implying a factor of safety 3.5. Thus the construction adopted for TS3CA is furthered for full tower.

4.7 Results of full tower testing for mechanical performance

The tower geometry is finalized by satisfying the electrical clearances. The external loads on the tower members are worked. Initially the tower members are designed using the member forces obtained from STAAD Pro software for the suggested loadings as discussed in the chapter.2. The structural analysis of 15 m full scale tower is carried out as per the loading conditions (Ref. loading tree 2.6). The maximum forces and their loading capacity of each member is verified as discussed in section 2.7. The deflection of tower is represented in Figure 4.19a and stresses in the tower members are shown in Figure 4.19b. The maximum deflection obtained from structural analysis in transverse direction is 205 mm and longitudinal direction 145 mm.

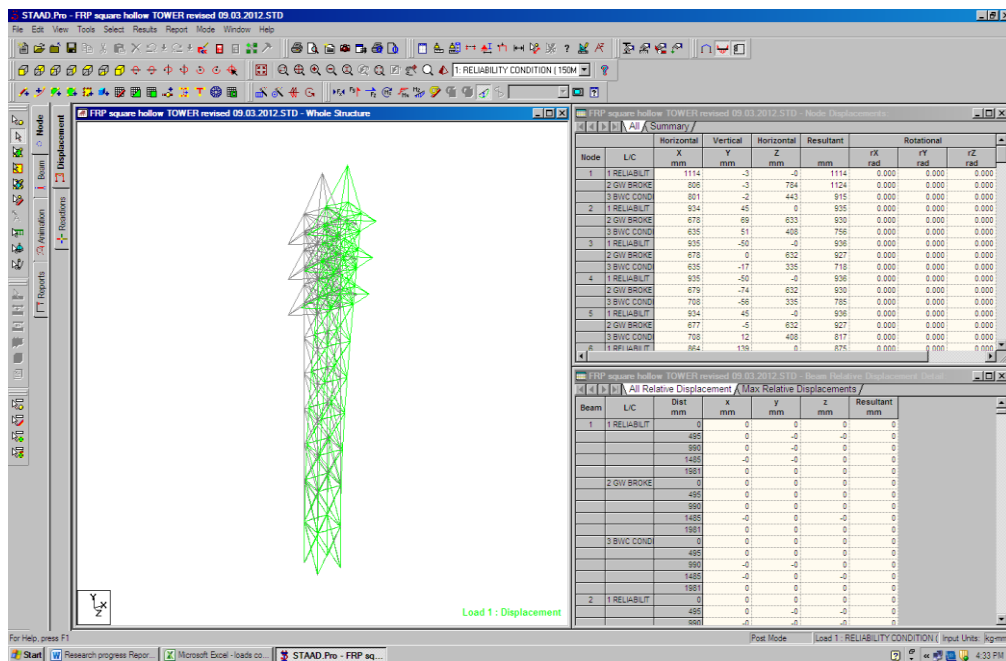

Fig. 4.19a Maximum deformations observed in members of full tower under load case 2 security condition – Earth wire broken

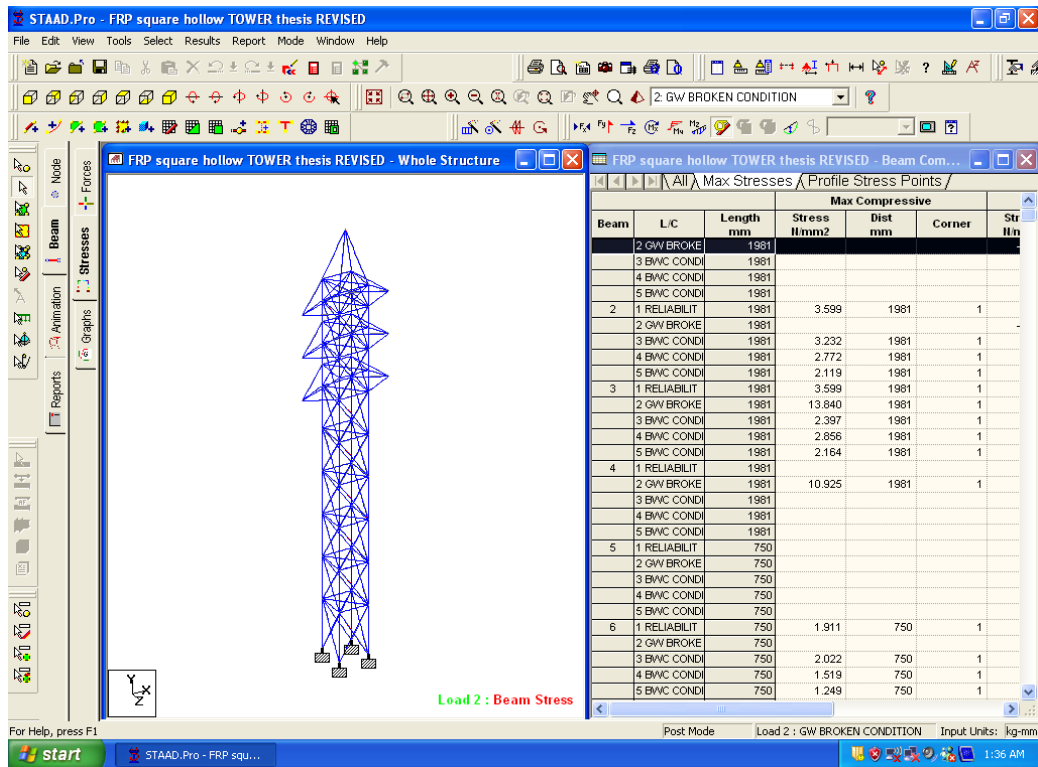

Fig. 4.19b Maximum stresses observed in members of full tower under load case 2 security condition - Earth wire broken

Physical testing of a full tower with composite members is conducted to validate the suitability established through structural analysis. The full tower of 15 m height is constructed with feature of TS3CA and tested for its mechanical strength as per the loads (Ref loading tree 2.6) recommended in the standard IS: 802 as explained in chapter 2. Figure 4.20 shows the deflection full tower during loading in transverse and longitudinal directions. The deflections measured at different points on the tower viz. earth wire peak (tower peak), top cross arm, middle cross arm and bottom cross arm levels at each stage of loads for different loading conditions are shown in Tables 4.16 to 4.20.



(a) Transverse direction



(b) Longitudinal direction

Fig.4.20 Photograph showing deflection of tower under load case 2 security condition
Earth wire broken during tower testing

Table.4.16 Measured deflection under reliability condition

Load (%)	Deflection in mm			
	Peak	Top cross arm	Middle cross arm	Bottom cross arm
0	0	0	0	0
50	30	30	20	20
75	95	65	60	60
90	160	110	90	80
95	180	130	110	100
100	210	150	130	120

Table.4.17 Measured deflection under security condition
(Earth wire broken)

Load (%)	Deflection in mm			
	Peak	Top cross arm	Middle cross arm	Bottom cross arm
0	0	0	0	0
50	20	130	100	80
75	50	130	100	80
90	80	135	105	85
95	160	140	110	90
100	170	140	110	90

Table.4.18 Measured deflection under security condition
(Top conductor broken)

Load (%)	Deflection in mm			
	Peak	Top cross arm	Middle cross arm	Bottom cross arm
0	0	0	0	0
50	10	20	15	10
75	40	30	20	20
90	60	45	30	30
95	60	65	50	40
100	50	85	55	50

Table.4.19 Measured deflection under security condition
(Middle conductor broken)

Load (%)	Deflection in mm			
	Peak	Top cross arm	Middle cross arm	Bottom cross arm
0	0	0	0	0
50	35	10	55	15
75	55	30	75	40
90	65	45	95	55
95	75	55	110	75
100	90	65	125	85

Table.4.20 Measured deflection under security condition
(Bottom conductor broken)

Load (%)	Deflection in mm			
	Peak	Top cross arm	Middle cross arm	Bottom cross arm
0	0	0	0	0
50	05	10	10	90
75	20	20	20	100
90	25	30	35	115
95	30	35	50	130
100	35	40	60	135

The measured deflections at different heights of full tower is plotted which is shown in Figure 4.21. It could be observed here that the deflection of full size tower is approximately linear with respect to loading. Details of tower deflections at various measuring points are provided in Table 4.21a to d. Deflections from FE analysis are also furnished in these tables for sake of comparison.

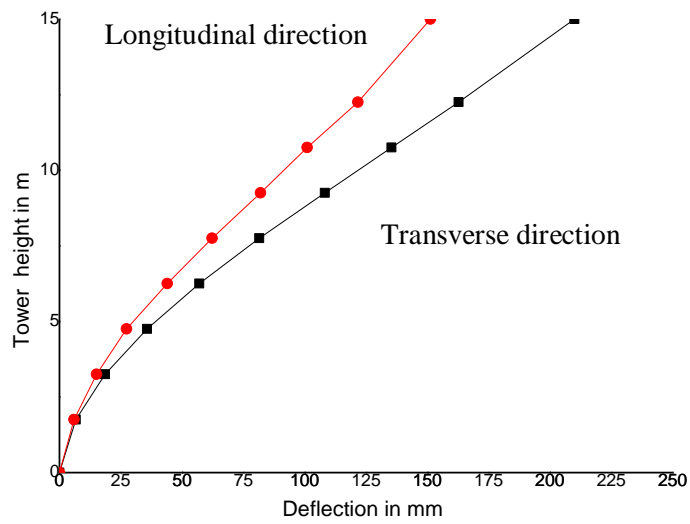

Fig. 4.21 Tower height versus deflection

Table 4.21a Table comparing deflections at the earth wire peak obtained from FEA and experiment

Test type	Deflection in mm			
	FEA		Experiment	
	Transverse	Longitudinal	Transverse	Longitudinal
Reliability	201.30	65	210	45
Security Earth wire	103.485	144.36	50	100
Security Top conductor	59.95	142.82	75	100
Security Middle conductor	48.58	144.92	55	110
Security Bottom conductor	37.86	141.16	35	110

Table 4.21b Table comparing deflections at the top cross arm obtained from FEA and experiment

Test type	Deflection in mm			
	FEA		Experiment	
	Transverse	Longitudinal	Transverse	Longitudinal
Reliability	25.27	156.05	10	150
Security Earth wire	17.88	112.32	70	170
Security Top conductor	17.91	110.70	80	120
Security Middle conductor	18.13	112.29	55	120
Security Bottom conductor	17.60	109.55	40	120

Table 4.21c Table comparing deflections at the middle cross arm obtained from FEA and experiment

Test type	Deflection in mm			
	FEA		Experiment	
	Transverse	Longitudinal	Transverse	Longitudinal
Reliability	25.35	129.93	10	130
Security Earth wire	17.98	93.67	10	85
Security Top conductor	17.82	92.26	10	110
Security Middle conductor	18.32	93.36	10	75
Security Bottom conductor	17.68	91.19	10	75

Table 4.21d Table comparing deflections at the bottom cross arm obtained from FEA and experiment

Test type	Deflection in mm			
	FEA		Experiment	
	Transverse	Longitudinal	Transverse	Longitudinal
Reliability	25.01	103.97	10	80
Security Earth wire	17.81	75.07	35	50
Security Top conductor	17.60	73.88	25	40
Security Middle conductor	17.89	74.72	20	50
Security Bottom conductor	17.61	72.86	20	135

It could be observed here that deflections measured during experimental testing are comparable with the deflections obtained from the structural analysis of full scale tower with composite members.

The tower with composite members is successfully withstood recommended design loads (Ref loading tree 2.6) as per IS: 802 without any visible sign of failure during waiting period of five minutes. When the loading is further continued, one of the leg members developed a crack near base of top cross arm indicating the first visible signs of failure shown in Figure 4.22a. Subsequently bracing at the bottom of the assembly (Figure 4.22b) sustained a shear failure at the bolted joint. The loads at the time of failure recorded as 34060 N longitudinal loads, 4465 N transverse load and 1700 N vertical load. These loads are about 300% of the loads suggested implying a factor of safety of the tower about 2.0 over and above the satisfactory one for security condition (IS: 802).



Crack developed

Fig. 4.22a Cracking of leg member at the base of top cross arm



Fig. 4.22b Bolt sheared off at the joint between leg and bracing

It could be observed from testing of the full tower that, the tower is not damaged under suggested operating conditions at 100% of recommended load. The tower's mechanical properties meet the performance requirements. The maximum transverse deflection of tower is only 1.4% and longitudinal deflection is 1.0 % of tower height (Ref. Figure 4.21) and are well within the requirement of 5% suggested in IS:800.

4.8 Results of testing cross arm for electrical performance

An attempt is made to study the performance of cross arm with composite members under electrical loadings as discussed in chapter 3. Initially single cross arm mounted on the 2.5 m tower unit is subjected to impulse withstand voltage test as suggested in IS:2071. The lightning impulse voltage versus time curve is obtained from the measuring system as shown in Fig 4.23a and b. Subsequently the power frequency voltage withstand test is carried out under wet condition as discussed in chapter 3. The power frequency withstand voltage as suggested in the standard IS:2165 is applied on the cross arm.

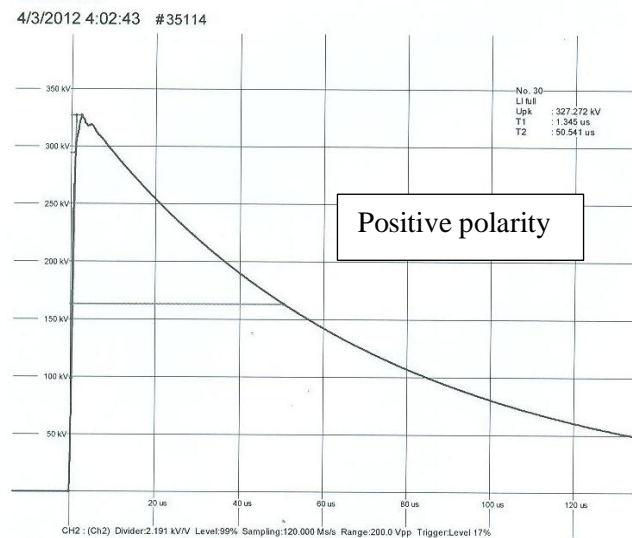

Fig. 4.23a Lightning impulse voltage/time curve for 66 kV composite cross arm

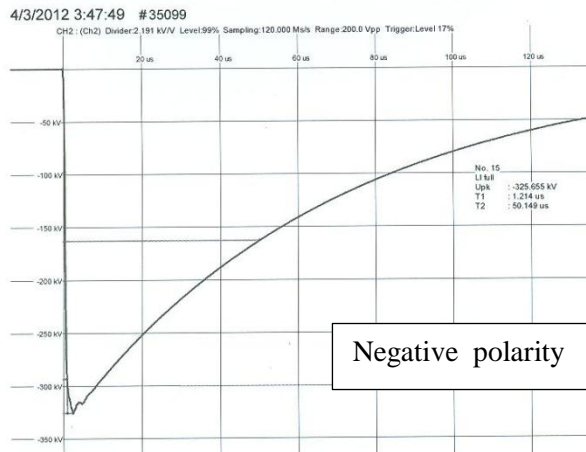

Fig. 4.23b Lightning impulse voltage/time curve for 66 kV composite cross arm

The cross arm with composite members withstood an impulse voltage of 328 kV and power frequency voltage of 150 kV without any flashover. These are on par with recommended values of 325 kV and 140 kV respectively for a 66 kV cross arm (IS:2165).

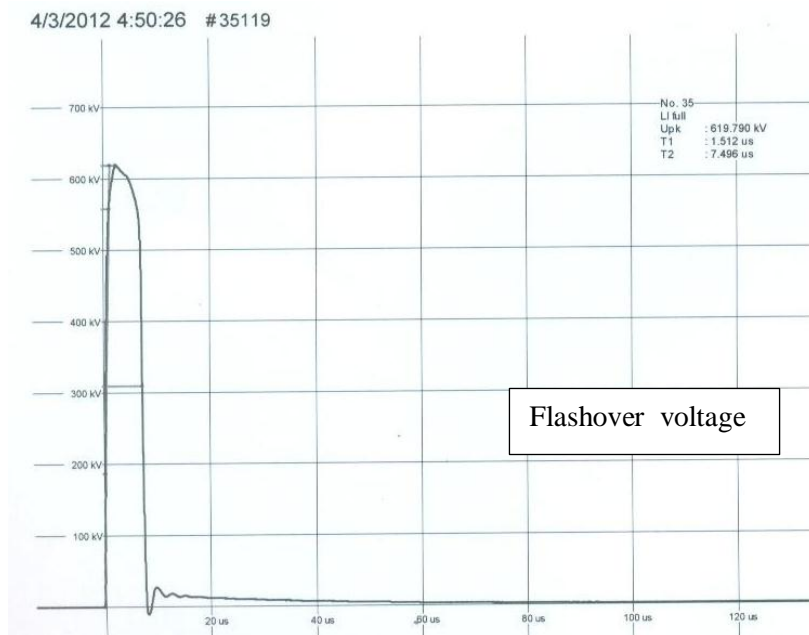

Fig. 4.23c Lightning impulse voltage/time curve for 132 kV composite cross arm

The same set up is checked for 132 kV requirement. It is observed that the voltage flashovers occurred at impulse voltage of 605 kV and power frequency voltage

of 262 kV. For 132 kV system, recommended values are 650 kV and 275 kV respectively. Thus it can be noted that the cross arm sustained almost the required magnitudes of electrical loadings suggested for 132 kV system i.e., the composite cross arm withstood as much as 85 % of requirement of 132 kV tower (Figure 4.23c).

4.9 Results of testing full tower for electrical performance

Electrical performance tests are conducted on the full tower with cross arm. All six cross arms mounted on full scale tower height of 15m is subjected to impulse withstand voltage test as per IS2071. The required voltage as suggested for in the standard IS:2165 is applied on the cross arm mounted on the tower. The lightning impulse voltage versus time curve is obtained from the measuring system as shown in Fig 4.24a and b. Subsequently the power frequency voltage withstand test is carried out under wet condition as discussed in chapter 3. The power frequency withstand voltage as suggested in the standard IS:2165 is applied on the cross arm.

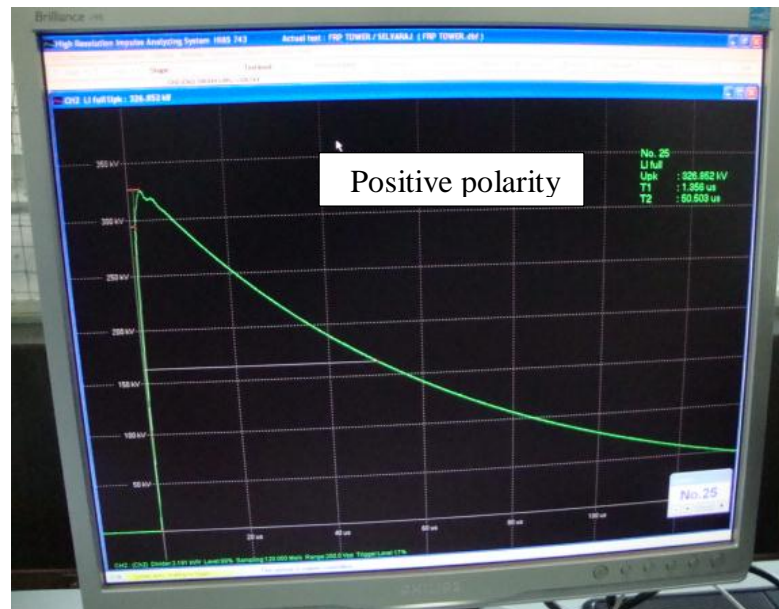

Fig. 4.24a. Lightning impulse voltage/time curve for 66 kV tower and cross arm with composite members

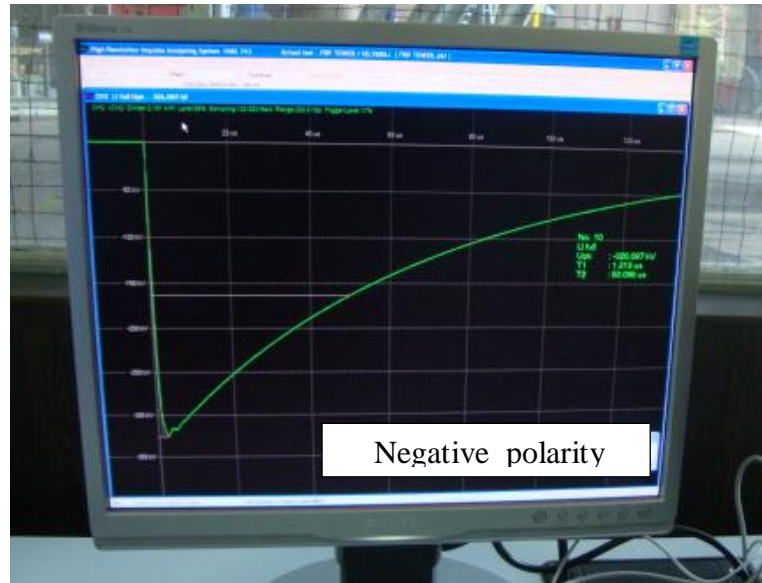

Fig. 4.24b. Lightning impulse voltage/time curve for 66 kV tower and cross arm with composite members

The tower with cross arm successfully withstood the impulse voltage of 328 kV and the power frequencies withstand voltage of 143 kV. It is observed that No flashover of voltages occurred at at the cross arm mounted on the tower. Thus the tower and cross arm with composite members successfully withstood impulse and power frequency withstand voltage test as per Indian Standard.

4.10 Savings in ROW and tower height with proposed tower of composite members

As explained earlier in chapter.1 Right of Way (ROW) is the width of the land strip accommodating the transmission lines. ROW for conventional transmission line and lines with proposed tower can be evaluated as below:

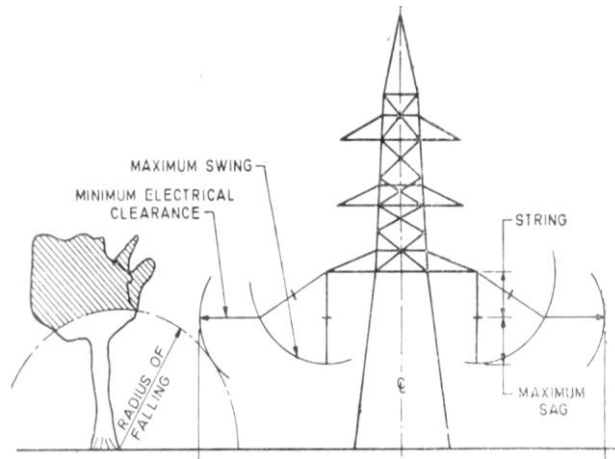

Fig.4.25. ROW requirement

For conventional lines

Conventional steel tower insulator length : 0.965 m

Maximum sag @ $75^{\circ}C = 5.25$ m (CBIP Manual No.9)

Minimum electrical clearance : 2.14m (IS 5613 Part- 2)

Length of steel cross arm : 1.75 m (2.75 m from centre)

Max.swing angle of insulator : 45° (for 66 kV)

$$\begin{aligned} \text{Conductor shift when insulator swings at } 45^{\circ} &= (0.965 + 5.25) \sin 45^{\circ} \\ &= 4.5 \text{ m} \end{aligned}$$

Half tower body width : 0.50m

$$\begin{aligned} \text{ROW} &= (4.5 + 2.14 + 0.50 + 1.75) \times 2 \\ &= 17.78 \text{ m} \approx 18 \text{ m} \end{aligned}$$

For lines with tower of composite members

Composite tower insulator length : No insulators used

Maximum sag @ $75^{\circ}C = 5.25$ m (CBIP Manual No.9)

Minimum electrical clearance : 2.14 (IS 5613 Part- 2)

Length of cross arm with composite members:1.0m (1.5m from centre)

Height of hanger : 0.1m

$$\begin{aligned} \text{Conductor shift at } 45^\circ &= (5.25 + 0.10) \sin 45^\circ \\ &= 3.80 \text{ m} \end{aligned}$$

Half tower body width : 0.50m

$$\begin{aligned} \text{ROW} &= (3.80 + 2.14 + 0.50 + 1.0) \times 2 \\ &= 14.88 \text{ m} \approx 15 \text{ m} \end{aligned}$$

ROW for 66 kV conventional steel tower is 18 m (IS: 5613) while it is 15m for proposed tower

$$\begin{aligned} \% \text{ savings in ROW} &= (18 - 15) / 18 \\ &= 16.66 \approx 17\% \end{aligned}$$

It could be observed that the Right of Way (ROW) requirement for a typical 66 kV line is effectively brought down by about 17%.

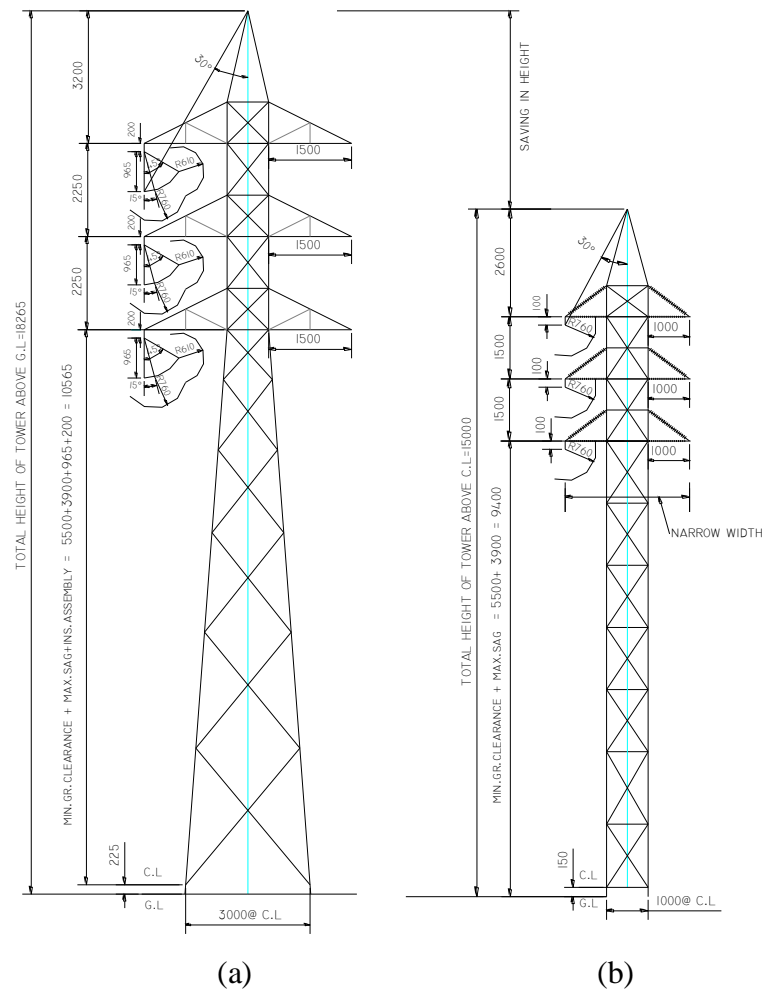

Fig 4.26 (a) Conventional steel tower (b) Proposed tower with composite members

The height of conventional steel tower : 18.265 m

The height of tower with composite member : 15m

$$\begin{aligned} \text{\% savings in tower height} &= 18.265 - 15.0 / 18.265 \\ &= 18 \% \end{aligned}$$

4.11 Savings in weight of the tower

The weight of the conventional steel tower for the same rating of 66 kV under suggested conditions is about 2500 kg (CBIP Manual No. 9). As can be seen from the calculation total weight of tower with composite members in chapter.3 is only 790 kg (Table 3.5) which is about one-third weight of the conventional steel tower. The tower with composite members is light in weight and helps in reduction of construction time, and labour cost.

CHAPTER 5

CONCLUSIONS

This chapter highlights the significant conclusions drawn from the results presented earlier. Major inferences from both analytical and experimental investigations are listed below.

The FE analysis of cross arm with composite members is yielding a factor of safety of 3.42 and 2.62 in reliability and security conditions respectively which is higher than the recommended safety factors of 3.0 and 2.0. The proposed tower with composite member is designed from the guide lines in standards and the properties of composite members processed through pultrusion. Design verification is envisaged through FE analysis. The cross arm assembly with composite members is taken as preliminary study. The stresses and strains in cross arm members obtained through FEA are well within the suggested ones for pultruded sections.

FE analysis of three proto type of tower units TS1, TS2 and TS3 sustained a maximum stress of 795MPa in the bracing members which is 2.8 times higher than the allowable of 283MPa. The proposed design TS1 failed in the verification of safety about 20% in TS2 and 65% in TS3 are obtained.

The results of characterization of GE pultruded material justified the suitability of use as a tower members. Tensile strength of the material is roughly about 3 times the strength of steel. Accelerated weathering/ageing test conducted on GE pultruded specimens indicated no dimensional changes in the specimen. The loss of weight and strength due to ageing are only about 10 % and 5 % respectively. Erosion rate of the material is also found to be less. The dielectric strength of material is found to be 30-35 % more than the recommended values as per ASTM G149.

Two methods of fixing end clamps on to composite members of cross arm are studied, adhesive bonding and crimping. The strength of joints with crimping process is about 35% more than adhesive bonding process. During mechanical testing of the cross arm, the overall deflection due to application of the loads in reliability condition is only about 44mm which is tolerable as per recommendations.

Three prototypes TS1, TS2 & TS3 are tested for a tower sub assembly. FE analysis of TS1 indicated failure in buckling of one of the bracings at a load of 100%. This aspect could be physically observed during the testing. Thus TS2 and TS3 which sustained the forces successfully are continued for further analysis.

Two proposals of tower with cross arm, TS2CA and TS3CA are studied. In the case of TS2CA the bracing suffered shear failures at the bolt hole. Loads recorded at the instance of failure are 6.2kN transverse load, 2.6kN vertical load and 20kN longitudinal load. These loads are about 2.4 times more than full load meeting the required safety factor of 2.0 as suggested for security condition. The prototypes TS3CA of tower sub assembly with cross arm successfully withstood the maximum loads of 8.7kN transverse loads, 4.5kN vertical load and 32kN longitudinal load. These loads are about 3.5 times higher than the recommended loads implying a factor of safety 3.5 more than 3.0 recommended for reliability condition.

The full tower is constructed to a height of 15m with composite members and six cross arms with composite members. It could be observed from the full tower test that, the tower indicated no signs of visible failure under suggested operating conditions and 100% of full load. Thus the tower satisfied the requirement under mechanical performance. The maximum deflection of tower top is 1.4% of tower height and is well within the requirement of 5%. When the loading is continued up to failure after satisfying the 100% full load condition one of the leg members developed a crack near the top of cross arm indicating first visible signs of failure. The loads at the time of failure are recorded as 34060N longitudinal load, 4465N transverse load and 1700N vertical load. These load are about 300% of the full loads suggesting a factor of safety of the tower about 3.0 which are satisfactory for both reliability and security conditions.

After successful completion of mechanical performance of the cross arm with composite members, electrical tests are carried out. The cross arm withstood the required impulse withstand voltage of 328kV which is higher than the recommended voltage of 325kV and in the case of power frequency test, the cross arm withstood 150kV which is higher than recommended voltage of 140kV. No flashover of voltage is observed during application of impulse voltage and power frequency test. Thus, the cross arm satisfies the mechanical and electrical requirements for a real life operation. It is observed, that the test voltages are increased to 132kV rating, the cross arm withstood only 85 % of the 132kV tower insulation requirement.

The full tower constructed with composite members to a height of 15m with six cross arm cross arm with composite members are subjected to impulse withstand voltage test and power frequency withstand voltage test. The full tower with cross arm withstood the impulse voltage of 328kV which is higher than the recommended voltage of 325kV and in the case of power frequency test, the full tower withstood 143kV which is higher than recommended voltage of 140kV.

A 66 kV transmission lines with proposed tower with composite members required right of way (ROW) is 15m as against 18m for conventional metallic towers. Thus about 17% saving is achieved in ROW requirement for 66kV lines. Height of the proposed tower is 15m against 18.265m for conventional tower. Thus a saving of about 18% is incurred in the tower height. The weight of the proposed tower is only 790kg as computed in chapter.3 while as weight of a conventional metallic tower for the same line is 2500kg. Thus a savings of 33% in weight could be achieved by going for tower with composite members. The height and weight of the tower drive the cost and the above savings reflect in reduction of tower cost. Added to this, the composite material used is not corroding and the associated maintenance and labor costs will be saved. Saving ROW help in reducing land cost which is a major contributor in the cost of transmission lines especially in urban areas.

Thus with advantages mentioned above the tower composite members could be suitable for areas where land cost is high and in earthquake prone zones. They can be used as Emergency Restoration System (ERS) towers also with great advantage in transporting and erecting the tower quickly and safely.

REFERENCES

- Albermani, F.G.A., Kitipornchai, S. (2003) “Numerical simulation of structural behavior of transmission towers” *Journal of Thin-walled structures*, 41,167-177.
- American Society of Civil Engineers (ASCE) Manual No.104 (2003), “*Recommended Practice for Fiber-Reinforced Polymer products for overhead utility line structures*”.
- American Society of Civil Engineers (ASCE) 10-90 (1991), “*Design of Latticed Steel Transmission Structures*”. New York, USA.
- A.Mehrtash, S.Afsharnia, M.A.Golkar,S.Kamlinia and H.Monsef (2007), “Assessment of overhead transmission line Right of way stand regulating in Iran”. *IEEE Xplore* 01.16, 800-805.
- ASTM D 570-98 (2006), *Standard Test method for Water Absorption of Plastics*, ASTM International, PA, USA.
- ASTM D 638-08 (2008), *Standard Test method for Tensile Properties of Plastics*, ASTM International, PA, USA.
- ASTM D 695-08 (2002), *Standard Test method for Compressive Properties of Rigid Plastics*, ASTM International, PA, USA.
- ASTM D 790-07 (2007), *Standard Test method for Flexural Properties of Unreinforced and Reinforced Plastics and Electrical Insulating Materials*, ASTM International, PA, USA.
- ASTM D 792 -08 (2008), *Standard Test methods for Density and Specific Gravity (Relative Density) of Plastics by Displacement*, ASTM International, PA, USA.
- ASTM D 149 -97a (1998), *Standard Test method for Dielectric Breakdown Voltage and Dielectric Strength of Solid electrical insulating materials at commercial power frequencies*, ASTM International, PA, USA.
- ASTM D 349 - 07 (2007), *Standard Test methods for Laminated Round Rods used for electrical insulation*, ASTM International, PA, USA.
- ASTM G 155 – 00a (2000), *Standard Practice for Operating Xenon Arc Light Apparatus for Exposure of Non-Metallic Materials*, ASTM International, PA, USA.
- A.Brent Strong (1989), *Fundamental of composites manufacturing: Materials, Methods, and applications*, Society of Manufacturing Engineers, Michigan.
- Anthony Kelly CBE, Robert W Cahn and Michael B.Bever (1989), *Concise Encyclopedia of composite materials*, Pergamon Press, New York.

Adb-El-Naby, S.F.M (1992), "Experimental and theoretical investigations of bolted joints for pultruded composite materials," PhD thesis, Dept. of Engrg., Univ. of Surrey, UK.

Acosta-Costa, F.J (1999), "Experimental characterization of the mechanical and structural properties of fiber reinforced polymeric bridge deck components", PhD thesis, School of Civil Engineering, Georgia Institute of Technology.

Aref, A.J (1997), "A novel fiber reinforced composite bridge structural system", PhD thesis, University of Illinois at Urbana-Champaign, USA.

Bradford, N. M (2004), "Design optimization of FRP composite panel building systems: Emergency shelter applications", PhD thesis, University of South Florida, Florida, USA.

Banks and J.Rhodes (1980), "The post buckling behaviour of composite box sections" *The Reinforced Plastics Congress, Brighton*, 85-88.

Bank, L.C., Yin, J., Moore, L., Evans, D.J. and Allison, R.W (1996), "Experimental and numerical evaluation of beam-to-column connections for pultruded structures " *Journal of Reinforced Plastics and Composites*, 15,1052-1067.

Bank L.C , Mosallam A.S and McCoy G.T (1994) " Design and performance of connections for pultruded frame structures", *Journal of Reinforced Plastics and Composites*, 13, 199-212.

Bansal.A, Schubert.A, Balakrishnan.M.V. and Kumosa.M (1995) "Finite element Analysis of Substation composite insulators", *Journal of Composite Science and Technology*, 55, 375-389.

Brian C. Wood, P.E and Timothy L.Moore P.E (2006), " Modifying existing 138 kV Transmission towers to 230 kV capacity". *IEEE Explore* 0-7803-9193-4, 1-5.

Bakis. G.E, L.C.Bank, V.L.Brown, E.Cosenza, J.F.Davalos, J.J.Lesko, A.Machida, S.H.Rizkalla and T.C. Triantafillou (2002), " Fiber-Reinforced polymer composites for construction – State-of-the- Art Review". *Journal of composites for construction*, 2(1), 73-87.

Burnham.J.T and T.M.Grisham (1994) " High strength polymer post insulators enable economical transmission lines with low environmental impact". *IEEE Xplore* 1883-494-499.

Barbero, E.J. and Raftoyiannis, I.G (1993), "Euler buckling of pultruded composite columns" *Journal of Composite Structures*, 24, 139-147.

- Central Board of Irrigation and Power (1977), New Delhi, India. “Manual on transmission line towers”, Technical Report No.9.
- Central Board of Irrigation and Power (1997), New Delhi, India. “Transmission line manual ”, Publication No.268.
- Chawla, K.K. (2001). *Composite materials*, Springer, New york.
- Chen.W.F, E.M.Lui (2010), Handbook of Structural Engineering, CRC Press, New York.
- Camanho.P.P and F.L.Matthews (1997), “ Stress analysis and strength prediction of mechanically fastened joints in FRP: a review” . *Journal of composites Part A*, 97, 529-547.
- Dale Douglass, Jim Stewart (2010), EPRI Transmission Line Reference Book - 115-345 kV Compact line design.
- Denis Dumora and Dominique Felimann (1990), “ Mechanical behaviour of flexurally stressed composite insulators”. *IEEE transactions on power delivery*, 5(2) , 1066-1073.
- Davalos, J.F, H.A. Salim, P.Qiao and R. Lopez-Anido (1996), “Analysis and design of pultruded FRP shapes under bending”. *Journal of composites Part B: Engineering*, 27, 295-305.
- Duriatti, D., Beakou, A. and Levillain, R (2006)., “Optimisation of the crimping process of a metal end-fitting onto a composite rod” *Composite Structures*, 73(3), 278-289.
- E.J.Barbero, S.Makkapati and J.S.Tomblin (1999), “ Experimental determination of the compressive strength of pultruded structural shapes”. *Journal of composites science and technology*, 59 , 2047-2054.
- El-Hajjar R.F (2004) “*Experimental study and analytical modeling of trans layer fracture in pultruded FRP composites*”, PhD Thesis, Georgia Institute of Technology, Atlanta, Georgia USA.
- Ghodrat Ollah Heidari, Maziar Heidari (2002) “*Effect of land price on transmission line design*”, CIGRE Session, Paris, 22-301.
- Gan, L.H., Ye, L. and Mai, Y.W (1999), “Design and evaluation of various section profiles for pultruded deck panels”, *Journal of Composite Structures*, 45(4), 719-725.
- Hollaway,L.C. (2005) “Advances in adhesive joining of dissimilar materials special reference to steels and FRP Composites” *Proc., Int. Symp. on Bond behavior of FRP in structures BBFS 2005*, 11-21.

H.Jannat Aliour, S.Aminnejad, M.Jazaeri (2007) “Decreasing the Right of Way of transmission lines by using towers with polymer insulation arms”, IEEE-POWERENG 2007, Portugal, 571-576.

Hsein -Yang Yeh and Samuel C.Yang. (1997) “Building of composite transmission tower”. *J. Reinforced Plastics and Composites* 16(5), 414-424.

Hsien-Yang Yeh, Hsien-Liang Yeh. (2001) “Simple failure analysis of the composite transmission tower”, *J. Reinforced plastics and composites*, 20 (12),1054-1065.

Han-ming LI and Shi-cong DENG (2010) “Research on composite material towers used in 110 kV overhead transmission lines”, IEEE X plore 2010.

Hassan, N.K. Mosallam, A.S (2004), “Buckling and ultimate failure of thin-walled pultruded composite columns”, *Journal of Polymers and Polymer Composites*, 12(6), 469-481.

IEC 60826 – 1 (1991), “ Loading and strength of overhead transmission lines, Geneve, Suisse.

IEC 60826 – 2 (1985), “Overhead line support loadings Part 2: wind and temperature loadings, Geneve, Suisse.

IEC 4892-2 (1994), “ Plastics – Methods of exposure to laboratory light sources”, Geneve, Suisse.

IEEE 524 (1980), “ Guide to the installation of overhead transmission line conductors” New York, USA.

IS: 802 (Part-I/Sec 1) : 1995 RA 2006 “ *Use of structural steel in overhead transmission line towers – Code of Practice*” Part I Materials, loads and permissible stresses.

IS: 802 (Part-3) : 1978 RA 2003 “*Code of practice for use of structural steel in overhead transmission line towers*” Part III Testing.

IS: 875 (Part 3) : 1988, Code of practice for design loads (other than earthquake) for buildings and structures : Part 3 Wind loads

IS: 5613 (Part -2/Sec 1) : 1985 RA 2002 and (Part 2 / Sec 2):1985 RA 2002, “*Code of practice for design, installation and maintenance of overhead power lines*”.

IS: 2071 (Part-I) : 1993 RA 2004 “*High Voltage test techniques : General definitions and test requirements*”.

IS:2071 (Part-II): 1974 RA 2006 “*Methods of High Voltage Testing : Test Procedures*”.

IS : 2165 (Part 2): 1983 RA 2006 , “ Phase to Phase Insulation coordination – Principles and Rules”

IS:398 (Part 2): 1996, RA 2002, Aluminium conductors for overhead transmission purposes- Specifications”

IS:2141 -2000 : “Hot dip galvanized stay strand-Specification”

James Slegers (2012), “Compact Transmission line design considerations” EPRI Transmission Line Reference Book. USA.

John Tomblin, Ever Barbero. (1994) “ Local Buckling Experiments on FRP columns” *Journal of Thin-Walled Structures*, 18, 97-116.

Nolasco .J.F et al.(1992) “ Use of ROW of overhead lines in urban areas- an experience in Brazil, CIGRE session.

Liao.K, C.R.Schultheisz and D.L.Hunston (1999), “ Effects of environmental aging on the properties of pultruded GFRP” . *Journal of composites Part B: Engineering*, 30, 485-493.

Keissling.F, P.Nefzger, J.F.Nolasco and U.Kaintzyk (2003), *Overhead Power lines, Planning, Design, Construction*, Springer.

Kuhl.M (2001) “FRP Rods for Brittle fracture resistant composite insulators” *IEEE Transactions on Dielectrics and Electrical Insulation* Vol.8, No.2.

Kunikazu Lzumi, Takeshi Takahashi, Hiroya Homma (2000) “Development of line post type Polymer insulation arm for 154 kV” *IEEE Transactions on Power Delivery* 15(4),1304-1310.

Kulkarni, S.M. (2002). “Processing, microstructural and mechanical behavior aspects of fly ash - epoxy composites”. Ph.D thesis, Indian Institute of Science, Bangalore.

Kollár, L.P (2003), “Local buckling of fiber reinforced plastic composite structural members with open and closed cross sections”, *Journal of Structural Engineering*, 129 (11), 1503- 1513.

Linda M.Vanevenhoven, Carol K. Shield and Lawrence C.Bank (2010) “ LRFDFactors for pultruded wide-flange columns”. *Journal of structural engineering*, 136 (5) 554-564.

Lawrence C.Bank (2006) “*Composites for Construction, Structural design with FRP materials*”. John Wiley and Sons, Inc.

Leonard Hollaway (1995), Hand book of polymer composites for Engineers, Jaico Publishing House, Bombay, India.

Marisa Pecce, Edoardo Cosenza (2000), “Local buckling curves for the design of FRP profiles”. *Journal of Thin-walled structures*, 37, 207 -222.

Mosallam, A.S., Abdelhamid, M.K., and Conway, J.H(1994), “Performance of pultruded PFRP frame connections under static and dynamic loads” *Journal of Reinforced Plastics and Composites*, 13(5), 386-407.

Madhujit Mukhopadhyay (2004) “*Mechanics of Composite Materials and Structures*”. University Press (India) private ltd. Hyderabad.

Marisa Pecce, Edoardo Cosenza. (2000) “ Local buckling curves for the design of FRP profiles” *Journal of Thin Walled structures*, 37, 207-222.

Miguel O.B.C.Melo Luiz C.A.Fonseca, Eduardo Fontana and S.R.Naidu (1998), “ Electric and magnetic fields of compact transmission lines”. *IEEE transactions on power delivery*, 14(1), 200-204.

Murthy.S.S and A.R.Santhakumar (1990), Transmission line structures, McGraw-Hill Book co.

Nihar Desai and Robert Yuan (2006), “ Investigation of Bending/Buckling characteristics for FRP composite poles”. Proceeding of the 10th biennial ASCE Aerospace division International conference on engineering and operation in challenging environments.

Pizhong Qiao, Julio F.Davalos and Brian Brown (2000) “ A Systematic analysis and design approach for single span FRP deck / stringer bridges”. *Journal of composites Part B : Engineering*, 31, 593-609.

Prabhakaran. R, Z.Razzaq and S.Devara (1996), “ Load and resistance factor design (LRFD) approach for bolted joints in pultruded composites”. *Journal of composites Part B: Engineering*, 27, 351-360.

Polyzois, D., and Raftoyiannis, I.G (2000), “Compression strength of pultruded equal leg angle sections”, *Journal of Structural Engineering and Mechanics*, 9 (6), 541-555.

Richard E.Chambers, P.E., Fellow ASCE (1997) , “ASCE Design standard for pultruded Fiber Reinforced Plastic structures”, *Journal of composites for construction*.

Robert M.Jones (1999), Mechanics of composite materials, Brunner – Routledge, New York & London,

Robert D. Castro (1995), “Overview of transmission line design process” *Journal of Electric Power Systems Research*, 35, 109-118.

Ravikant shrivastava, Uttamasha Gupta, Choubey U.B (2009) , “FRP: Research, Education and Application in India and China in Civil Engineering”, *International Journal of Recent Trends in Engineering*, 1(6), 89-93.

Sotiropoulos S.N, Ganga Rao H.V.S , Mongi A.N.K (1994), “Theoretical and Experimental Evaluation of FRP components and systems” *Journal of Structural Engineering*, 464-485.

Sedlacek.G, Trumpf.H, Castrischer.U (2005) “Development of a light weight emergency bridge” *Structural Engineering International (SEI). Journal of International Association for bridges and structural engineering (IABSE)* 154, 282-287.

Sims, G.D., Johnson, A.F. and Hill, R.D (1987), “Mechanical and structural properties of GRP pultruded section”, *Journal of Composite Structures*, 8 (3), 173-187.

Thomas Keller, Till Vallee (2004), “Adhesively bonded lap joint from pultruded GFRP profiles Part II: joint strength prediction”. *Journal of composites Part B: Engineering*, 36, 341-350.

Walt Warner, Ebert Composites Corp (1997), “Easily constructed composite towers carry electricity” *Reinforced Plastics*, USA.

List of Publications based on PhD Research Work

Sl. No	Title of the paper	Authors	Name of the Journal/Conference/Symposium, Vol., No., Pages	Month and Year of publication
1	Analysis and Experimental testing of a built-up composite cross arm in a transmission line tower for mechanical performance	<u>M.Selvaraj</u> , S.M.Kulkarni, R.Ramesh Babu	Composite Structures Vol.96, pp 1-7	Feb. 2013
2	Behavioral Analysis of built up transmission line towers from FRP pultruded sections	<u>M.Selvaraj</u> , S.M.Kulkarni, R.Ramesh Babu	International Journal of Emerging Technology and Advanced Engineering Vol.2, No.9 pp 39 - 47 (ISSN:2250-2459)	Sep. 2012
3	Structural Evaluation of FRP pultruded sections in overhead transmission line towers	<u>M.Selvaraj</u> , S.M.Kulkarni, R.Ramesh Babu	International Journal of Civil and Structural Engineering Vol.2, No.3, 2012 pp 934-940 (ISSN: 0976-4399) doi:10.6088/ijcser.00202030021	Feb. 2012
4	Design and Performance Evaluation of FRP cross arm for transmission line towers	<u>M.Selvaraj</u> , S.M.Kulkarni, R.Ramesh Babu	The Journal of CPRI, Vol.5, No.2 pp 25-31. (ISSN: 0973-0338)	Sep. 2009
5	Performance Analysis of 66 kV Overhead Transmission line tower using Polymer Composite material	<u>M.Selvaraj</u> , S.M.Kulkarni, R.Ramesh Babu R.S.S.Aradhya	IEEE Transaction on Dielectrics and Electrical Insulation (DEIS) (Paper No. 3926 under review from January 2013)	-----

Sl. No	Title of the paper	Authors	Name of the Journal/Conference/Symposium, Vol., No., Pages	Month and Year of publication
6	Development of Transmission line tower with FRP composite material	<u>M.Selvaraj</u> , S.M.Kulkarni, R.Ramesh Babu	Proceedings of 4 th Intl. Conference GRIDTECH2013 New Delhi, Organized by M/s. POWERGRID with support of Ministry of Power, Govt. of India, pp 109-116	April 2013
7	Performance Evaluation of Transmission line tower built from FRP composite material	<u>M.Selvaraj</u> , S.M.Kulkarni, R.Ramesh Babu	Proceedings of Association of Consulting Civil Engineers (I), Mangalore Centre	Jan 2013
8	Studies on FRP Pultruded Structural Sections for transmission line towers	<u>M.Selvaraj</u> , S.M.Kulkarni, R.Ramesh Babu	Proceedings of International Conference on Mechanics of Nano, Micro and Macro Composite Structures Organized by Politecnico di Torino, Italy Abstract No.272.	June 2012
9	Compact Transmission line towers with composite materials	<u>M.Selvaraj</u> S.M.Kulkarni, R.Ramesh Babu	Proceedings of National Workshop on Compact Transmission lines, organized by Central Power Research Institute (CPRI), Bangalore, India. pp 21-34	Feb. 2012
10	Behaviour of FRP pultruded sections in transmission line towers	<u>M.Selvaraj</u> S.M.Kulkarni, R.Ramesh Babu	Proceedings of International conference on Design and Advances in Mechanical Engineering (ICDAAME 2011) organized by SKP Engineering College, Tiruvannamalai, India. pp 65-69	Dec. 2011

Sl. No	Title of the paper	Authors	Name of the Journal/Conference/Symposium, Vol., No., Pages	Month and Year of publication
11	Development of Compact Transmission line tower with polymer insulation arms	<u>M.Selvaraj</u> , S.M.Kulkarni, R.Ramesh Babu	Proceedings of National Conference on Latest Trends in Design and Testing of Transmission line components, Central Power Research Institute (CPRI), Bangalore, India pp 7-11	Nov. 2010
12	Experimental Evaluation of Fiber Reinforced Composite Cross arm for power transmission line towers	<u>M.Selvaraj</u> , S.M.Kulkarni, R.Ramesh Babu	Proceedings of International Conference on Frontiers in Mechanical Engineering (FIME 2010), NITK, Surathkal, India, pp.53, (ISBN-13 9788191028515)	May 2010
13	Structural Assessment of FRP cross arm for power transmission line towers	<u>M.Selvaraj</u> , S.M.Kulkarni, R.Ramesh Babu	Proceedings of International conference on Advances in Materials and Techniques in Civil Engineering (ICAMAT2010) VLBJ College of Engineering and Technology, Coimbatore, India, Sl. No. 31, pp. 195-199, 07-09 (ISBN:9788190578547)	Jan. 2010

BIODATA

Name	M. Selvaraj			
Email	msraj@cpri.in , msraj1993@gmail.com			
Contact No.	080-23604664 (office), +91 9449851236 (Mobile)			
Address for communication	Engg. Officer Mechanical Engg. Division Central Power Research Institute (CPRI) Bangalore -560 080 Karnataka, INDIA	Permanent Address	No.22, Type .4, CPRI Colony, New BEL Road, Bangalore -560 012 Karnataka, INDIA	
Education Qualification	B.E. Mechanical, Govt. College of Engineering, Salem, University of Madras. M.E. Engg. Design, College of Engg. Guindy, Anna University, Chennai. Ph.D. NITK, Surathkal, “Performance Evaluation of Power Transmission line tower made of polymer matrix composite”			
Industry experience	20 years			
	Research & Development in the areas of power transmission line towers, Consultancy services on new design, design approval and Testing of transmission line towers and its components to various power utilities including overseas customers.			
Teaching experience	01 year worked as a lecturer			
	Subjects handled are : Machine Design, Machine Drawing, Strength of Materials.			
Computational skills	Drafting package : AutoCAD, Analysis package : ANSYS, MSC-NASTRAN, PLSCADD,STAAD Pro			
No. of Publications	International Journals	05	National Journals	03
	International Conference	07	National Conference	10