

ENERGY EFFICIENT NETWORK ARCHITECTURE FOR INTERNET OF THINGS APPLICATIONS

Thesis

Submitted in partial fulfillment of the requirements for the degree of
DOCTOR OF PHILOSOPHY

by

P. SARWESH

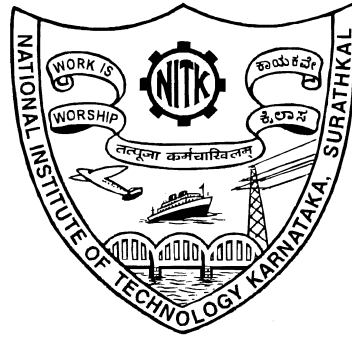

DEPARTMENT OF ELECTRONICS AND COMMUNICATION
ENGINEERING
NATIONAL INSTITUTE OF TECHNOLOGY KARNATAKA
SURATHKAL, MANGALORE -575025

October, 2018

Dedicated to my beloved parents and my wife...

DECLARATION

I hereby *declare* that the Research Thesis entitled **ENERGY EFFICIENT NETWORK ARCHITECTURE FOR INTERNET OF THINGS APPLICATIONS** which is being submitted to the *National Institute of Technology Karnataka, Surathkal* in partial fulfillment of the requirement for the award of the Degree of *Doctor of Philosophy* in **Department of Electronics and Communication Engineering** is a *bonafide report of the research work carried out by me*. The material contained in this Research Thesis has not been submitted to any University or Institution for the award of any degree.

P.SARWESH

Reg. No. 135043EC13F05

Department of Electronics and Communication Engineering.

Place: NITK-Surathkal.

Date:

CERTIFICATE

This is to certify that the Research Thesis entitled **ENERGY EFFICIENT NETWORK ARCHITECTURE FOR INTERNET OF THINGS APPLICATIONS** submitted by **P.SARWESH** (Reg. No. 135043EC13F05) as the record of the research work carried out by him, is accepted as the *Research Thesis submission* in partial fulfillment of the requirements for the award of degree of **Doctor of Philosophy**.

Dr. N. Shekar V. Shet

Research Adviser

Associate Professor

Dept. of Electronics and Communication Engg.

NITK Surathkal - 575025

Chairman-DRPC

(Signature with Date and Seal)

Acknowledgements

Every successful work is completed by the dedication and coordination of many people. Its my duty to kindly acknowledge the people who helped me to succeed in my research journey.

Firstly, I am very lucky to have Dr. N. Shekar V. Shet, Associate Professor, department of E&CE, NITK as my research guide. Without his motivation and guidance, this research work would be impossible. I pledge my sincere gratitude for his encouragement and guidance. He is one of the biggest factors for me considering NITK as a second home during my stay here.

My special and sincere thanks to Prof. K. Chandrasekaran, Professor, department of CSE, NITK for his constant guidance in my research career. Chandrasekaran sir is my roll model, his unbounded support, research guidance, affection and keen care towards me made me, successfully complete this research work. His motivation and encouragement developed positive impact in this research work as well as in my life.

My special and hearty thanks to Prof. Muralidhar Kulkarni, Professor, department of E&C, NITK for his technical and philosophical guidance. He is my well wisher, I would like to pledge my sincere sense of gratitude for his encouragement, guidance and support. M. Kulkarni sir is the biggest inspiration in my life.

I wish to thank Prof. U. Shripathi Acharya, Professor and Head, department of E&C, NITK for providing me the necessary resources and support for carrying out my research work. I have been benefited by his enriched knowledge.

Special thanks to Prof M. S. Bhat, department of E&CE, NITK for his support and guidance. I also would like to thank Prof John D'Souza and Prof Sumam David S. department of E&CE, NITK for their support throughout my research work.

I am very much thankful to Dr. Prashantha Kumar H. department of E&CE, NITK for his guidance and motivation. His encouragement and unbounded knowledge inspired me to do this research work. I would like to thank Dr. Mohit P. Tahiliani, department of CSE, NITK who helped me to learn NS-2 and NS-3 to validate my research work.

My sincere thanks to Prof. P. Santhi Thilagam, Professor and Head, department of CSE, NITK and Dr. A. V. Narasimhadhan department of E&CE, NITK for their valuable suggestions and guidance to complete this research work.

I would like to thank Dr. Ramesh Kini M., Dr. T. Laxminidhi, Dr. Ashvini Chaturvedi, Dr. Rekha S., Dr. Aparna P., Dr. M. R. Arulalan, Dr. Shyam Lal, Dr. Raghavendra B.S., Dr. Rathnamala Rao, Dr. Pathipati Srihari, Dr. Krishnamoorthy K., Dr. Kalpana G. Bhat, Dr. Deepu Vijayasenan, Dr. B. Nagavel department of E&CE, NITK for their support for carrying out my research.

I would like to thank all supporting staff of the department, but in particular Smt Pushpalatha, Sri Subramanya Karanth, Smt Amitha P. Amin, Sri Sanjeeva Poojary, Sri Tilak, Sri Ratheesh for their support throughout my research work.

I have had a good fortune in making an ample number of friends during my stay at NITK. I am lucky to have wonderful friends in NITK, they never let me to feel like I am away from my home. The support and sacrifice of my Father K. Periyasamy and My Mother P. Jayanthi during my whole research period, just cant be explained. Finally I thank my wife S Dhurga who is the lucky icon for me.

Sarwesh P.

Abstract

Internet of Things is emerging as one of the efficient technology solutions to fulfill the requirements in various fields of the modern communication and computation era. Assorted challenges remain for the Internet of Things(IoT) technology, in that one of the vital problems is unbalanced energy utilization. Some of the IoT applications are run by battery sourced devices. Therefore, efficient energy utilization is the major requirement in low power IoT networks. Initially, a systematic literature survey has been carried out on node placement techniques and energy aware routing protocols, since these techniques are primarily involved in energy optimization. Observations from literature survey have resulted in development and design of an energy efficient network architecture. The proposed network architecture integrates the features of routing and node placement technique. However, it has been observed that the implementation of routing and node placement technique takes additional execution time. Therefore, we come up with energy efficient cross layer model that integrates two different optimizations techniques in the same phase of the network. The proposed cross layer model converges routing technique and MAC based power control technique to attain the optimal transmission range for every node in the network. The cross-layer model that prolongs network lifetime with better reliability and QoS can be considered as an energy efficient network for IoT applications. Therefore, a novel ETRT-based cross layer model that prolongs network lifetime with better reliability and QoS is finally explored in our research work. The proposed architectures are validated through simulations. From simulation results, we observed that our network architectures and cross layer models outperform the standard model (IEEE 802.15.4 with AODV) and EQSR protocol. In this thesis, we attempt to suggest that effective integration of node placement technique and routing technique prolongs the network lifetime. Moreover cross layer design that predicts the capability of the node, decidedly prolongs the network lifetime and improves the network performance.

Keywords: Internet of Things; Network Architecture; Energy Efficiency; Routing Technique; Node Placement Technique; Cross Layer Model.

Contents

Acknowledgements	i
Abstract	iii
List of figures	vii
List of tables	ix
Nomenclature	x
Abbreviations	x
1 INTRODUCTION	1
1.1 INTRODUCTION TO INTERNET OF THINGS	1
1.2 FEATURES OF IOT NETWORK	6
1.2.1 Features of Low Power IoT Devices	6
1.2.2 Features of Low Power Radio links	6
1.3 MOTIVATION	7
1.3.1 Importance of Communication Unit Optimization	10
1.3.2 Node Placement Technique	10
1.3.3 Routing Technique	10
1.3.4 Cross-Layer Design	11
1.4 PROBLEM STATEMENT, OBJECTIVES AND RESEARCH CON- TRIBUTIONS	12
1.4.1 Research Objectives	12
1.4.2 Research Contributions	13
1.5 ORGANIZATION OF THE THESIS	15
2 LITERATURE SURVEY	17
2.1 INTRODUCTION	17
2.2 ROUTING	18
2.2.1 Attribute-Based Protocols	18

2.2.2	Flat Protocols	18
2.2.3	Geographical Routing	19
2.2.4	Hierarchical Protocols	19
2.2.5	Multi path Routing	19
2.2.6	Energy Aware Routing Protocols	20
2.3	ENERGY EFFICIENT NODE PLACEMENT TECHNIQUES	24
2.4	CROSS LAYER MODELS	26
2.5	SUMMARY	28

3 ROUTING AND NODE PLACEMENT INTEGRATED NETWORK

	ARCHITECTURE FOR LOW POWER IOT NETWORKS	29
3.1	INTRODUCTION	30
3.2	NODE PLACEMENT AND ROUTING INTEGRATED NETWORK ARCHITECTURE	30
3.2.1	Network Parameters	32
3.2.2	Energy Model	32
3.2.3	Node Placement Technique - Node Density Variation	33
3.2.4	Routing Technique	36
3.2.5	Weight Factor Calculation	38
3.2.6	Route Selection by Destination Node	38
3.3	ROUTING AND NODE PLACEMENT INTEGRATED NETWORK ARCHITECTURE WITH BATTERY LEVEL VARIATION	41
3.3.1	Node Placement Technique - Battery Level Variation	42
3.3.2	Routing Mechanism	43
3.4	ROUTING AND NODE PLACEMENT INTEGRATED NETWORK ARCHITECTURE WITH TRANSMISSION RANGE VARIATION	45
3.4.1	Node Placement Technique - Transmission Range Variation	45
3.4.2	Blue Print of Proposed Network Architectures	47
3.5	SIMULATION RESULTS AND PERFORMANCE ANALYSIS	49
3.5.1	Basic Assumptions	49
3.5.2	Simulation Parameters	50
3.5.3	Performance Parameters	50
3.5.3.1	Network Lifetime	50
3.5.3.2	Average Energy Consumption	51

3.5.3.3	Throughput	52
3.6	SUMMARY	53
4	NODE DEGREE AND TRAFFIC LOAD BASED CROSS LAYER MODEL	55
4.1	INTRODUCTION	55
4.2	CROSS LAYER MODEL FOR LOW POWER IOT NETWORKS . . .	56
4.3	OVERVIEW OF ND and TL BASED CROSS LAYER MODEL	58
4.3.1	Network Model	58
4.3.2	Power Consumption Model	60
4.3.3	Network Parameters	61
4.3.4	Routing Mechanism	61
4.3.5	Weight Factor Computation	62
4.3.6	Network Specification to Adopt IoT Scenario in the Simulation Scenario	64
4.3.7	Simulation Results and Analysis	64
4.3.7.1	Specifications of the Simulation Scenario	64
4.3.8	Performance Evaluation	64
4.3.8.1	Network Lifetime:	64
4.3.8.2	Average Energy Consumption	66
4.3.8.3	Throughput	66
4.4	SUMMARY	67
5	ETRT BASED CROSS LAYER MODEL	69
5.1	INTRODUCTION	69
5.2	OVERVIEW OF ETRT BASED CROSS LAYER MODEL	70
5.2.1	Network Model	71
5.2.2	Network Parameters	73
5.2.3	Routing Mechanism for ETRT based Cross Layer Model	74
5.2.4	Deriving ETRT based on Weighted Sum Approach	75
5.2.5	Estimation and Utilization of Nodes Capability Information . .	77
5.2.6	Simulation Results and Analysis	79
5.2.6.1	Specifications of the Simulation Scenario	79
5.2.6.2	Performance Evaluation	79
5.2.7	Network Lifetime:	79

5.2.7.1	Average Energy Consumption	84
5.2.7.2	Throughput	84
5.2.7.3	END-to-END Delay	84
5.2.7.4	Highlights of ETRT based cross layer model	85
5.3	SUMMARY	85
6	CONCLUSION AND FUTURE DIRECTIONS	87
	Bibliography	90
	Publications based on the thesis	102

List of Figures

1.1	IoT world forum reference model and IoT challenges	3
1.2	Factors that affects energy efficiency	9
3.1	Basic idea of proposed network architecture	31
3.2	Specifications node density variations	36
3.3	Control packet structure of proposed network architecture	39
3.4	Route selection process used for proposed network architecture	40
3.5	Specifications of battery level variations	42
3.6	MAC based power control technique used for proposed network architecture	46
3.7	Specifications of transmission range variations	47
3.8	Blue print of proposed network architecture	48
3.9	Network lifetime estimation of proposed network architecture	51
3.10	Average energy consumption analysis for proposed network architecture	52
3.11	Throughput analysis for proposed network architecture	53
4.1	Blue Print of ND and TL based cross layer model	59
4.2	Control packet structure of ND and TL based cross layer model	63
4.3	Network lifetime estimation for ND and TL based cross layer model	66
4.4	Average energy consumption analysis for ND and TL based cross layer model	67
4.5	Throughput analysis for ND and TL based cross layer model	68
5.1	Blue Print of ETRT based cross layer model	72
5.2	Control packet structure of ETRT based cross layer model	76
5.3	Operational flow of proposed cross layer model	78
5.4	Network Lifetime Estimation of ETRT based cross layer model	80

5.5	Network Lifetime Estimation of ETRT based cross layer model for three different parameters	81
5.6	Average energy consumption analysis for ETRT based cross layer model.	82
5.7	Throughput analysis for ETRT based cross layer model.	82
5.8	End to End Delay analysis for ETRT based cross layer model.	83
6.1	Summary of this research work	89

List of Tables

- 1.1 Comparisons of Internet and IoT 7
- 2.1 AODV Extensions 24
- 3.1 Network Parameters 33
- 3.2 Simulation Setup 50
- 3.3 Network lifetime estimation of proposed network architecture 52
- 4.1 Simulation setup 65
- 4.2 Network lifetime estimation of ND and TL based cross layer model . . . 65
- 5.1 Network lifetime estimation of ETRT based cross layer model 80

Abbreviations

Abbreviation	Expansion
AODV	Ad-hoc On Demand Distance Vector
AODV-AP	AODV - Accessibility Prediction
AODV-BA	AODV- Break Avoidance
AODV-D	AODV - Delay Aware
AOMDV	Ad-hoc On demand Multipath Distance Vector Routing
BER	Bit Error Rate
CBEERP	Cluster based Energy Efficient Routing Protocol
CISCO	Corps Information Systems Control Officer
CQIC	Cross-Layer Congestion Control Model
CRAHNS	Cognitive Radio Ad hoc Networks
EAD	Energy Aware Data Centric Protocol
EARP	Energy-Aware Routing Protocol
EAODV	Enhanced AOMDV
EAOMDV	Enhanced AOMDV
EECA	Energy Efficient Clustering Algorithm
EECS	Energy Efficient Clustering Scheme
EEDC	Energy Efficient Dynamic clustering
ELCH	Extending lifetime of Cluster Head
EQSR	Energy Efficient and QoS Aware Multipath Routing Protocol
ETD	Expected Transmission Delay
ETP	Expected Throughput
ETRT	Expected Transmission Range Threshold
ETSI	European Telecoms Standards Institute
ETT	Expected Transmission Time
ETX	Expected Transmission Count
GEAR	Geographical and Energy Aware Routing
GRAB	GRAdient Broadcast
HAN	Hints and Notifications
HEED	Hybrid Energy-Efficient Distributed Clustering
IEEE	Institute of Electrical and Electronics Engineers

Abbreviations

Abbreviation	Expansion
IETF	Internet Engineering Task Force
ITU	International Telecommunication Union
IoT	Internet of Things
IoT- GSI	IoT Global Standards Initiatives
IoT -WF	IoT World Forum
IP	Internet Protocol
LEACH	Low-Energy Adaptive Clustering Hierarchy
MAC	Media Access Control
MCFA	Minimum Cost Forwarding Algorithm
MEMS	Micro Electro Mechanical Systems
M-MPR	Meshed Multipath Routing
ND	Node Degree
OMG	Object Management Group
OSS-TWR	One-Sided Synchronous Two-Way Ranging
QoS	Quality of Service
PEGASIS	Power Efficient Gathering protocol
PLEACH	Partition LEACH Algorithm
RE	Residual Energy
REST	Representation State Transfer
RFID	Radio-Frequency IDentification
RREP	Route Replay
RREQ	Route Request
SAR	Sequential Assignment Routing
SMAC	Sectorized-Antenna Medium Access Control
TEEN	Threshold Sensitive Energy Efficient Protocol
TL	Traffic Load
UDP	User Datagram Protocol
WF	Weight Factor
WSN	Wireless Sensor Networks

Chapter 1

INTRODUCTION

Outline of the Chapter

- Section 1.1 gives an overall introduction to the Internet of Things (IoT).
- Section 1.2 describes the characteristic features of IoT network.
- Section 1.3 presents the motivation of the research work and background knowledge of node placement technique, routing technique and cross layer design.
- In Section 1.4, the research problems have been formulated and research contributions are described.
- Section 1.5 presents the gist of this thesis.

1.1 INTRODUCTION TO INTERNET OF THINGS

In recent years, the Internet of Things (IoT) is famed as a smart technology that unifies the internet-enabled devices and attains global information sharing. The major aspiration of IoT technology is to accomplish efficient resource utilization. Therefore IoT technology is implemented and practiced in many private organizations (Smart retail and e-health) and public organizations (smart city and smart grid). Internet of Things (IoT) is the integrated architecture of assorted technologies such as communication, embedded systems, ubiquitous computing, data processing, cloud computing, smart device design, networking, etc. In future, IoT will be indispensable for several

applications such as e-health, home automation, industrial automation, smart market, environmental monitoring, military applications etc. In the Internet of Things, the word "Things" includes the objects from RFID tag to aircraft, and with the help of networking technology, these "Things" are connected to the global network infrastructure. Therefore, by utilizing IoT technology, any object from anywhere at any time can be connected globally (I. T. U., and Unit, (2005), Al-Fuqaha, et al. (2015), Atzori, L. et al. (2010)) Internet of Things can be defined as "Expanded Internet", since it converges the internet enabled smart devices (sensor/actuator, RFID, Bio-chip, drones, multimedia device, etc.) with existing Internet architecture. Even though IoT is a recent notion, the technologies that are involved in IoT design are quite matured. Therefore, the possibility of implementing IoT technology is possible in various fields. Presence of standard wired and wireless technologies with effective communication and computing framework can promote effective interaction between machine-to-machine, machine-to-person, person-to-machine, etc. In IoT applications, Internet featured IoT devices work in a smarter way with their basic capabilities such as identifying, sensing, tracking, deciding, actuating, etc. In future communication and computation era, billions of smart devices are expected to be connected globally (Lee et al. (2011), Vasseur, J. P. et al. (2010), Botta, A. et al. (2016), Gubbi, J. (2013), Chen, S. et al. (2014) Singh, D. et al. (2014)) Therefore, with the help of IoT technology, unified network infrastructure, ubiquitous address spacing, energy efficient and reliable communication, scalable network infrastructure, secure data transfer can be achieved and billions of smart devices will be operated together. Many research groups such as ITU, IETF, IEEE, ETSI, OMG, OASIS, IoT-GSI are working towards IoT challenges and IoT development process (Sheng, Z. et al. (2013)).

Figure 1.1 describes the overview of IoT architecture. With the help of IoT world forum reference model, we have described the IoT architecture in this report. IoT world forum reference model (IOT-WF) is introduced by the CISCO (CISCO (2014)). It is an integration of query based data processing layers, event based data processing layers and data accumulation layer. In an IoT network, IoT devices process the data and they transmit the data globally. The IoT reference model is comprised of seven layers, which is required to maintain complete IoT system. In Figure 1.1, lower layers are referred as event based data processing layers. In IoT-WF, lower layers (edge computing layer, connectivity layer and edge device layer) aggregates and processes the event based data (real time data). Higher layers are referred as query based data

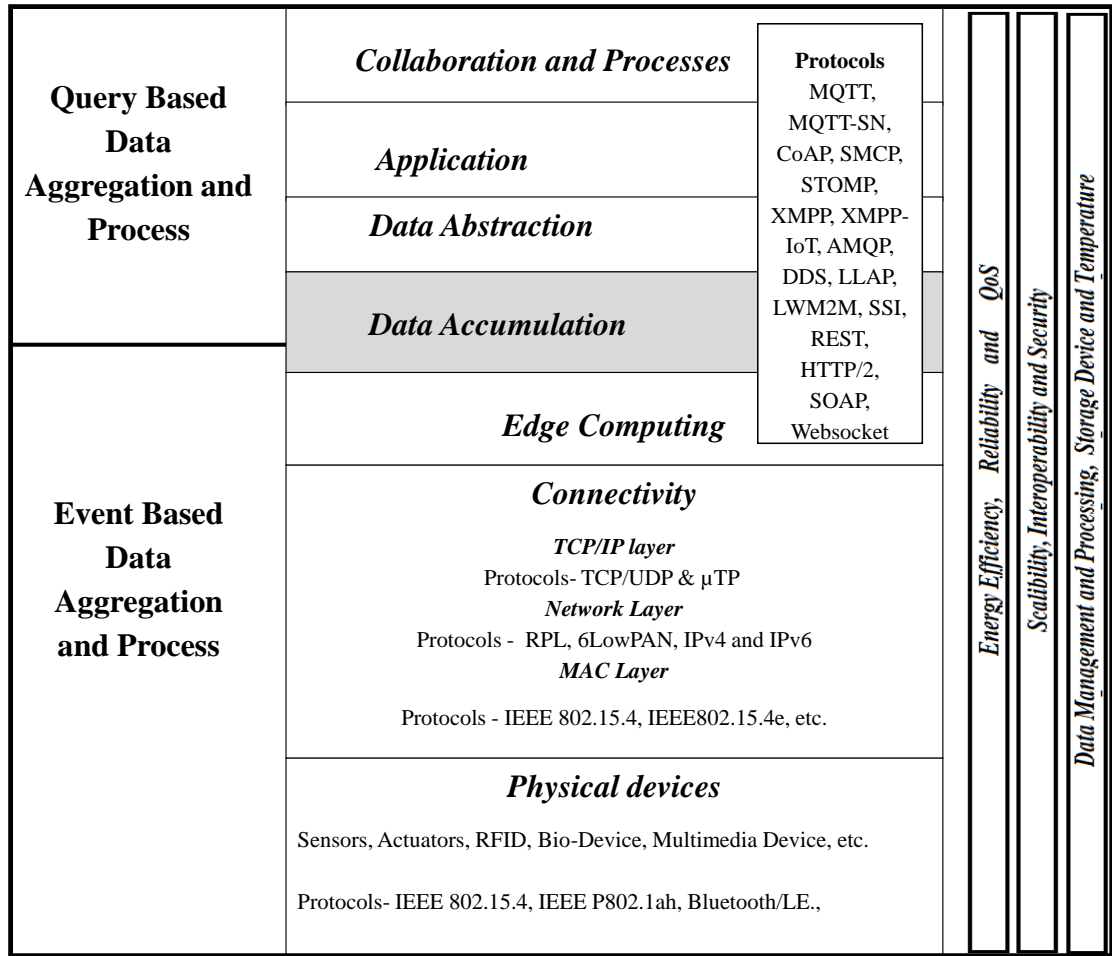

Figure 1.1: IoT world forum reference model and IoT challenges

processing layers. Higher layers (collaboration and processes layer, application layer, data abstraction layer) aggregates and process the query based data (non-real-time data). The middle layer is responsible for data storage. The following describes the features of seven layers in IoT -WF reference model.

- *Layer 1: Physical Devices and Controllers*

Physical devices (sensor devices) collects the physical information (temperature, speed, health information, etc.) and it process the information and transmits to the controllers, that controls various types of devices. These devices transmits and receives data through the global network infrastructure. An extensive variety of IoT devices are available in the market, which may be in the size of

a small tag, some be large sized. All these devices are designed with the help of dozens of equipments. IoT devices and controllers play a major role in event based data aggregation and processing.

- *Layer 2: Connectivity*

Connectivity between various types of IoT devices is the major challenge in IoT network since reliable data transfer needs to be provided among extensive variety of IoT devices. Traditional communication networks follow the data transmission based on stateless auto configuration and other features. Some of the IoT devices requires communication gateways to interact with other devices and the connectivity equipment for communication from one device to other device, differ from each other. Thus, providing connectivity between IoT devices is the major concern in IoT network.

- *Layer 3: Edge Computing*

In IoT WF reference model, information processing system collects and computes the information from edge devices, which is referred as edge computing. The main function of this layer is to collect information from IoT devices and convert the information for further data processing and storage. This layer does high volume of data transfer and analysis.

- *Layer 4 : Data accumulation layer*

Data accumulation layer is responsible for storing the data, which are generated by other layers. This layer changes the data in motion to data in rest; it handles huge amount of data or bulk data. It accumulates the data in memory and retrieve the data, when it is required. This layer does bridging between event-based data aggregation and processing and query-based data aggregation and processing.

- *Layer 5: Data Abstraction*

Storage systems in IoT applications need to accommodate IoT device data and data from traditional enterprise, therefore multiple storage systems are required to maintain and process this data. Therefore, data abstraction layer is required to maintain the relational data base management system and to reduce the user

query time. Data abstraction involves reconciling multiple data formats, data consolidation, data confirming, etc.

- *Layer 6: Application*

IoT applications vary from each other based on business needs and user needs. For example, some applications concentrate on environmental monitoring; some will concentrate on industrial automation, some will concentrate on power grids, etc. Therefore, the complexity of every application will vary from each other. Thus IoT has more scope on the wide variety of applications.

- *Layer 7: Collaboration and Processes*

IoT influences the human behavior since IoT involves people and processes. Applications perform the business logic and do efficient resource utilization to empower people. People utilize the IoT applications to satisfy their requirements. Often, many people utilize the same application for various purposes. Therefore, the objective of the IoT technology is not only the application development, it is also to empower the people to do their work efficiently.

- *Challenges*

The major challenges in lower layers are energy efficiency and reliability since the devices used in lower layers (edge computing layer, connectivity layer and edge device layer) are operated by battery sourced devices and low power radio links. Achieving efficient energy utilization among low power devices, while maintaining reliable data transfer and QoS in IoT network is the major challenge. Designing efficient storage devices and controlling the temperature that is dissipated from storage devices are the major challenges in the middle layer (data accumulation layer) since they store huge amount of data or bulk data. Data processing is the major concern in higher layers (collaboration and process layer, application layer, data abstraction layer). In IoT applications, various types of data from various applications will be generated. Processing the data from multiple resources, maintaining and responding to them for user query is the challenging task in IoT. security, interoperability and scalability are overall challenges for IoT applications since IoT applications handle multiple devices in common network platform. In our research work, we are concentrating on

challenges(energy efficiency and reliability) faced by lower layers and these are being addressed.

1.2 FEATURES OF IOT NETWORK

Internet of things (IoT) is the unified network that manages higher-end devices (servers) as well as lower-end devices (sensor devices) in single network platform. International Telecommunication Union (ITU) states that with the help of IoT technology anything can communicate with each other at any time from any location. Micro-Electro-Mechanical Systems (MEMS) technology is the prime reason for IoT development since various low cost and low power devices are developed by MEMS technology. The low power devices (battery sourced devices) and low power radio links (IEEE 802.15.4) are the fundamental components of IoT networks. Therefore IoT network can be referred to as low power IoT networks (Vasseur, J. P. et al. (2010)). The following sub section details the features of low power IoT networks.

1.2.1 Features of Low Power IoT Devices

IoT featured sensor or actuator devices interact with physical signals, such as temperature, pressure, image, etc. and transmits these physical signals to the base station. The IoT devices work in a smarter way with their basic capabilities such as sensing, actuation, computation, communication, etc. The microprocessor of IoT devices does the computation for effective data processing. The communication unit facilitates the IoT devices to communicate with each other and to communicate with the base station. The battery source provides the required energy for IoT device. Internet featured devices are capable to communicate with the global network. From these features, it is noticed that IoT devices are smart in nature, but they are constrained by energy since they are operated by battery sourced devices. Therefore, energy is the most valuable resource in low power IoT networks (Singh, D. et al. (2014)).

1.2.2 Features of Low Power Radio links

Some of the IoT applications deal with low power radio links, IoT links are mentioned as low power links, since they utilize lower bandwidth.

Table 1.1: Comparisons of Internet and IoT

Feature	Internet	Internet of Things
Device	Routers	Sensors/actuators
Medium	Reliable links	Low power links
Battery	Non-Constrained	Constrained
Address	IP Address	IP Address
Routing	Query based	Event based

Ethernet and optical links used for Internet applications exhibit low bit error rates (low BER). Where IoT network is operated by low powered and low capacity links that may exhibit high bit error rates (high BER). Therefore, the chance of packet loss is very high in low power IoT networks. When packet loss increases, data transmission needs to be re-initiated, which affects the energy efficiency as well as the reliability of the network. (Azzedine Boukerche (2008), Lee et al. (2011)) Hence, reliable data transfer is also the prime requirement in low power IoT networks. From Table 1.1, it is understood that IoT network is resource constrained in nature and it differs from regular Internet. Therefore efficient energy utilization and reliable data transfer are the major requirements for low power IoT networks.

1.3 MOTIVATION

The network that satisfies customer as well as service providers in all aspects such as network lifetime, reliable data transfer and QoS assurance can be considered as an efficient network for low power IoT networks. The major issues that affect the performance of low power IoT networks are energy hole and multiple-retransmissions. The IoT network scenarios adopt many to one traffic model (nodes to base station). In many to one traffic model, nodes located far away from base station holds minimum data traffic and nodes deployed adjacent to base station handles huge data traffic (data traffic of overall network). Nodes near to base station drain out its power in short span of time, this issue is referred as energy hole issue. The other major issue that highly influences the energy efficiency and reliability of the network is multi re-transmissions. Transmitting data in unreliable links is the prime reason for Multi re-transmissions. Energy hole and multi re-transmissions highly influence the energy efficiency of the network. Energy efficiency of the network can be achieved by avoiding energy hole issue and multi-retransmission issue. Figure 1.2, describes the major factors that

affect the energy efficiency of the network. The following describes the major factors that affect the energy efficiency and reliability of the network.

- *Interference*: Interference is an unwanted signal that destroys the original signal. Interference can be caused due to different reasons such as, multiple radio sharing the single channel, environmental conditions, noise, etc. Assigning the default value to each radio set may cause severe interference, the chance of interference is more when multiple radios shares the bandwidth on the single channel. In some cases, hidden nodes produce cyclic redundancy check (CRC) code errors, which leads to interference referred as co-channel interference or the adjacent channel interference. Interference severely affects the network performance, because the chance of bit error rate (BER) is more in unstable links (low power links), so necessary steps are required to avoid interference in network (Azzedine Boukerche (2008)).
- *Energy hole (Node Overload)*: The smart devices which are close to the base station handle huge data transmission since they forward their own, sensed data and data forwarded from other nodes, as a result of huge data load, nodes drain out its power in short span of time (Azzedine Boukerche (2008)). When every node near to base station drains out its battery source, communication to the base station will be blocked, which leads to network re-initialization, this problem is referred as energy hole issue. Energy hole problem severely affects the network performance, cost and time. Thus, balancing energy consumption and avoiding node overload can be the better solution to avoid energy hole issue.
- *Multiple - Retransmissions*: In IoT networks, the quality of radio links will vary frequently. Data transmission in unstable links leads to packet loss, which is the prime reason for data re-transmission (Azzedine Boukerche (2008)) . Data re-transmission affects the network reliability as well as energy efficiency. Thus, avoiding re-transmission decidedly improves the network performance. Data-re-transmissions can be avoided by transmitting data in stable links (reliable links).
- *Control packet overhead*: Extra data (control packets) required for specific protocol to establish association and correspondence is referred as packet overhead. These control packets are specified as RREQ and RREP. These packets are the

prime reason for establishing the communication, with the aid of this network information connectivity is maintained. Therefore, control packets are the fundamental need for establishing the connection, but it should not exceed its limit, which severely affects the energy efficiency of the network. Avoiding excess control packet usage (huge control overhead) can improve the energy efficiency with better network Connectivity (Azzedine Boukerche (2008)).

The above issues are the major factors that affects the energy efficiency and reliability of the network. In these factors energy hole and multiple - retransmissions severely affects the lifetime of IoT networks. Energy hole can be reduced by constant monitoring of energy level of nodes, multiple-retransmission can be avoided by transmitting data in reliable links. Thus, in this research work communication unit is optimized to reduce energy hole and multi-retransmission.

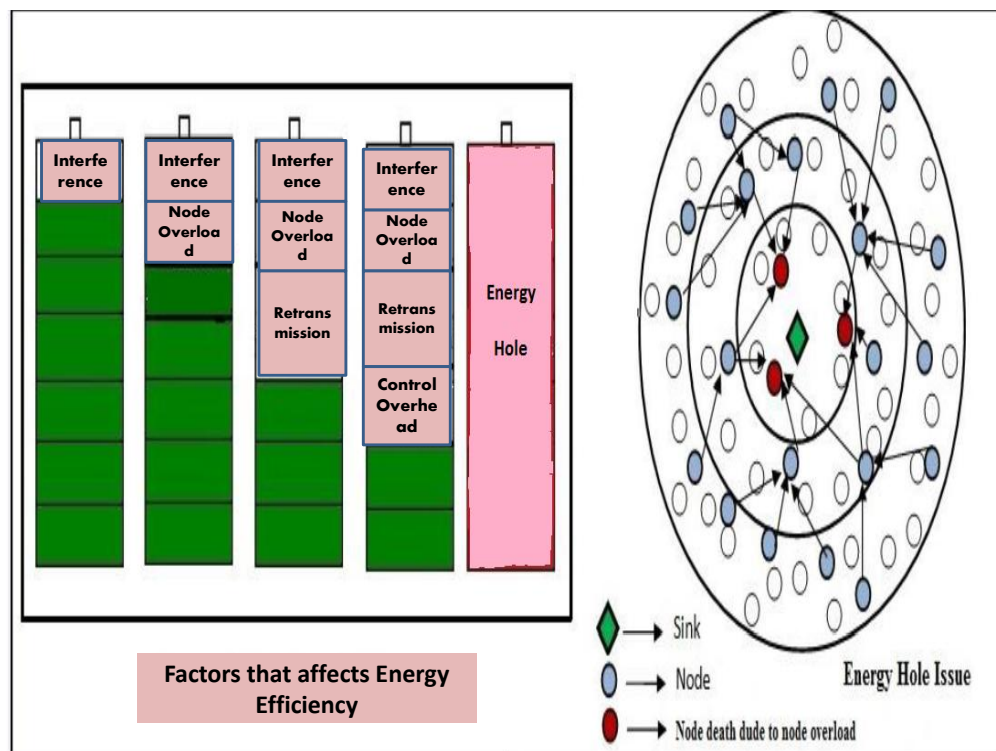

Figure 1.2: Factors that affects energy efficiency

1.3.1 Importance of Communication Unit Optimization

The smart device is designed by various components such as transmitter antenna, receiver antenna, transducer, processor, actuator. Among these components, the considerable measure of device power (70 % to 80% of energy) is consumed by the transmitter and receiver of the device (Azzedine Boukerche (2008)). Regulating the communication decidedly improves the overall network performance. To govern the communication unit in an optimized way, the techniques that regulate the communication unit need to be analyzed. This motivated us to concentrate on popular energy optimization techniques such as routing technique, node placement technique and cross layer design. These are the major techniques that are involved in optimizing energy hole and multi-retransmissions.

1.3.2 Node Placement Technique

The main challenges that are involved in constructing IoT Networks are network connectivity, the lifetime of battery sourced devices, data integrity, reliable communication, scalability, etc. Various optimization techniques are being addressed to attain network requirements. In network optimization techniques, deploying the nodes optimally in the network environment is one of the key techniques to achieve network connectivity and energy efficiency. Efficient node placement regulates the communication unit of the sensor devices and helps to prolong the lifetime of sensor devices. Many node placement techniques (Bari, A. (2005), Cheng, X. et al. (2008), Efrat, A. et al. (2005), Pan, J. et al. (2005), Yu, Y. et al. (2011), Zhao, E. et al. (2008)) has been carried out to optimize the network connectivity and network traffic. Placing nodes in a hierarchical manner can hold the lifetime of sensor devices for the long period. Placing special type of nodes called relay node in network field gives additional features to enhance the node placement technique Bari, A. (2005). Node placement is one of the efficient technique that improves the network lifetime. Initially, we carried out our research work by analyzing the features of flat based network scenario and various challenges that are involved in optimization of node placement technique.

1.3.3 Routing Technique

In modern communication and computation era, development of compact and low-cost smart devices made IoT and WSN as feasible technologies. Providing better connec-

tivity between sensor devices and prolonging the lifetime of the low power smart device are the prime requirements for wireless networks. Routing plays an effective role in managing device power, device connectivity, data dissemination etc. Routing achieves network level challenges in any kind of network design (Azzedine Boukerche (2008), J. L. Gao (2010), Intanagonwiwat et al. (2000), Ye, F et al. (2001), Rao, A. et al. (2003), Heinzelman, W. R. et al. (2000), Ganesan, D. et al. (2001), Bahuguna Renu et al. (2013), Yu, Y. et al. (2001)) Effective routing can satisfy the application specific network requirements. Therefore, routing is the essential technique for every network applications. Routing is classified into three types namely, Flat based routing (network is designed without specific structure). Hierarchical based routing (arranging network devices in a hierarchical manner). Location based routing (nodes location information is used for routing). Characteristics features of every application vary from each other. Designing a smart device based on application specific network requirements may increase the design complexity. Therefore, developing the routing mechanism is the effective solution to achieve application specific network requirements. Specifically, energy efficiency and reliability are prime needs in IoT Networks. Thus, we concentrate on designing a routing mechanism that achieves balanced energy utilization and reliable data transfer, which is the major objective of our research work.

1.3.4 Cross-Layer Design

Wired networks and wireless networks adopt standard protocol architecture (open system interconnection model). But in standard protocol architecture, information flow feasibility from one layer to the other layer is restricted, which may reduce the network performance. Cross layer design can overcome these limitations since it enables the interaction between various layers (allowing information flow between each layer) and optimizes the network performance. Various cross layer proposals are introduced for wireless networks (Srivastava, V. et al. (2005), Xylomenos, G. et al. (2001), Larzon, L. A. et al. (2002), ElBatt, T. et al. (2004), Dimic, G. et al. (2004), Tong, L. et al. (2004), Liu, Q. et al. (2004)). Cross layer design varies from each other based on their information flow, such as upward flow, downward flow, back and forth flow, merging two adjacent layers, coupling various layers without creating extra interfaces and vertical calibration across layers. Cross layer design also has some limitations; which increases the network complexity by creating additional layer interface.

From the analysis of energy efficient optimization techniques, it is observed that every optimization technique has specific features to enhance the network performance. Various cross layer design proposals describe that integrating the features of various layers in a single network architecture gives better network performance. This motivated us to propose node placement technique and routing technique integrated network architecture and later, we proposed energy efficient cross layer designs in our research work. The network architectures and cross layer models proposed in this research work, mainly concentrate on prolonging the network lifetime.

1.4 PROBLEM STATEMENT, OBJECTIVES AND RESEARCH CONTRIBUTIONS

The major aim of this research work is to design an energy efficient and reliable network architecture that promotes balanced energy utilization and reliable data transfer in low power IoT networks. Correspondingly, the research problem is stated as follows :

To design and develop an energy efficient network architecture, by integrating and utilizing the features of various layers together in a single network architecture.

Based on the problem statement, research objectives are specifically illustrated in the following sub Section.

1.4.1 Research Objectives

1. To integrate an energy efficient routing mechanism and node placement technique that enhances the lifetime of smart devices in an energy constrained IoT network.
2. To integrate the features of node placement technique and energy efficient routing technique in a single network architecture, for obtaining balanced energy utilization and reliable data transfer in IoT networks.
3. To design a cross layer model by integrating routing technique and MAC based power control technique, to improve the energy efficiency of the IoT network without compromising the reliability and Quality of service.

The research work carried out to achieve the research objectives are illustrated in following sub Section.

1.4.2 Research Contributions

The following are the research contributions that are carried out in our research work to achieve our research objectives.

- **Initially a systematic literature survey is carried out on routing techniques, node placement techniques and various cross layer designs.**

From our literature review, it is seen that energy hole issue and multi-retransmission issue are the major issues that affect the energy efficiency and reliability of the IoT network. Therefore a study on energy optimization techniques such as, routing techniques, node placement techniques and various cross layer designs have been carried out.

- **Objective 1 - Routing and node placement integrated network architecture is proposed.** From the literature survey, it is observed that the routing and the node placement technique are effective techniques to optimize the network lifetime. To utilize the features of both routing technique and node placement technique, we integrated them into single network architecture. In routing technique, parameters such as ETX and residual energy are included, to compute energy efficient and reliable path for data transmission. In node placement technique, the density of nodes is increased towards the base station, to regulate data traffic. The simulation results of proposed architecture outperform the standard network model.
- **Objective 1 and Objective 2 - Routing and node placement integrated network architecture is proposed. In this network architecture, battery level of nodes are varied.**

In the initial part of our research work, node placement technique is optimized by varying the density of nodes, which balances the data traffic and improves energy efficiency. But increasing node density increases the control overhead and the implementation cost. Therefore, to overcome these issues, battery level of nodes are varied in the network scenario concerning the data traffic. In routing

technique, ETX is replaced by ETT to avoid inter flow interference and intra flow interference. Thus, the proposed network architecture is enhanced by including various features.

- **Objective 1 and Objective 2 - Routing and node placement integrated network architecture is proposed. In this network architecture, the transmission range of nodes are varied.** Varying the battery level of nodes, balances the data traffic and reduces control overhead. It increases device complexity and implementation complexity. Instead of varying battery levels of nodes, varying transmission range of nodes can be effective solution to overcome this issue. Thus, node placement with variable transmission ranges is implemented. The proposed network architecture, overcomes the issues such as energy hole, multi-retransmission, inter flow interference intra flow interference and device complexity etc. From simulation results, it is seen that the proposed network architecture outperforms standard model and other network architectures that are proposed in the initial stage of our research work. Therefore, it can be suitable network architecture for low power IoT networks.
- **Objective 3 - Traffic load and node degree based cross layer model is proposed.** In routing and node placement integrated network architecture, node placement is done in network setup phase and routing is done in network initialization phase, which increases the network implementation time. To overcome this issue, we proposed the energy efficient cross layer model that integrates routing technique and MAC based power control technique in the same phase of network operation time. In routing technique, node degree and traffic load information are included for route discovery process, later MAC based power control technique utilizes the routing information and assigns suitable transmission range for every node in the network. Simulation results describe that proposed cross layer model prolongs network lifetime and it outperforms standard model and EQSR standard cross layer protocol.
- **Objective 3 - ETRT- based cross layer model is proposed.** The traffic load and node degree based cross layer model concentrates only on energy efficiency, where reliability and QoS information need to be considered to enhance the overall network performance. This motivated us to develop a novel cross layer model named as ETRT- based cross layer model which integrates physical

layer, data link layer (MAC layer) and network layer in the protocol stack. In our model, a threshold value called ETRT (Expected Transmission Range Threshold) is introduced, which determines nodes capability, it is computed by the aid of routing information. Later, MAC based power control technique utilizes ETRT value and assigns optimum transmission range for every node. The basic idea of proposed cross layer model is estimating the capability (ETRT value) of the node and assigning the suitable transmission power for every node based on its capability (ETRT value). The performance of ETRT based cross layer model is much better than standard cross layer model and EQSR cross layer design.

The aforementioned research contributions states that, research objectives are achieved by proposing energy efficient network architectures and cross layer models. And we say that proposed network architectures and cross layer models are more suitable for low power IoT Networks.

1.5 ORGANIZATION OF THE THESIS

- A literature survey on the techniques that are used to optimize the IoT network is essential to develop an energy efficient network architecture. Therefore, a detailed survey of energy optimization techniques such as, routing technique, node placement technique and cross layer design are done and presented in Chapter 2.
- Energy efficiency and reliability are the major challenges in IoT network. In our research work, the network architecture that integrates routing and node placement technique is proposed. The main objective of the proposed network architecture is to regulate the data traffic, to avoid uneven energy consumption and to achieve reliable data transfer. The main metrics involved in this network architecture are data traffic, residual energy and Expected transmission time (ETT). Data traffic is handled by node placement technique, residual energy and ETT are handled by routing technique. Chapter 3 elaborates the overall features of routing and node placement integrated network architecture.
- Routing and node placement technique integrated network architecture improves the network lifetime efficiently, but it increases the implementation time and

network re-initialization time. Therefore, a cross layer model can be the effective solution to achieve better network lifetime with less implementation time. Chapter 4 introduces an energy efficient cross layer model that integrates routing technique and MAC based power control technique, to achieve optimum transmission range for every node in the network.

- Although, cross layer model proposed in Chapter 4 is energy efficient, but it considers only energy efficient routing metrics for optimizing transmission range of nodes, where reliability and QoS related information are missing. Thus, novel cross layer model named as ETRT- based cross layer model is proposed and presented in Chapter 5. The basic idea of the proposed cross layer model is estimating the capability (ETRT value) of the node and assigning the suitable transmission power for every node based on its capability (ETRT value).

Chapter 2

LITERATURE SURVEY

Outline of the Chapter

- Section 2.1 presents the need for energy efficient data communication in IoT networks and factors that affect the energy efficiency in IoT Networks.
- Section 2.2 describes the various types of routing protocols, suitability of AODV routing protocol for low power IoT networks and various versions of AODV routing protocol.
- Section 2.3 elaborates the features of various node placement techniques and importance of relay node placement in IoT Networks.
- Section 2.4 presents the concept of cross layer design, different types of cross layer designs and various cross layer proposals developed for IoT Networks.
- Finally, Section 2.5 summarizes this Chapter.

2.1 INTRODUCTION

IoT technology is smart as well as resource constrained since it is operated by battery sourced devices and low power radio links. Often battery replacement and providing high bandwidth to low power devices are impossible in the IoT network scenario . Therefore, energy efficient techniques used to optimize the lifetime of IoT networks are the prime need for IoT applications Azzedine Boukerche (2008). Therefore, it is essential to do a literature survey on energy efficient techniques that improves the network lifetime.

2.2 ROUTING

Routing refers to establishing the routes that data packets take on their way to a particular destination. Routing protocols use various metrics to evaluate the path, to transmit the data. In any kind of network, most of the energy related issues are resolved with the aid of efficient routing mechanism. In grid powered network (Internet), routing framework is developed to improve the QoS and reliability, where as in IoT Networks routing framework is developed to achieve energy efficiency. Many literature works describe that routing plays a key role in minimizing the energy consumption of the network (Bahuguna Renu et al. (2013), J. N. Al-Karaki et al. (2004), J. L. Gao (2010)). Routing protocols are broadly classified into six categories. The following sub sections describe the various types of routing protocols.

2.2.1 Attribute-Based Protocols

Attribute-based protocols are independent of device specifications (Azzedine Boukerche (2008)). In Attribute-based routing mechanism, routing metric information is added in the control packet of routing protocol, based on this information nodes collect the environmental information and compares the collected information with other nodes and takes their own decision (either to forward or drop the packet). Directed diffusion routing mechanism (Intanagonwiwat et al. (2000)), energy-aware data-centric routing (EAD) protocol (Boukerche, A. et al. (2003)), RUMOUR protocol (Braginsky, D. et al. (2002)) are the well-known examples of Attribute-based protocols.

2.2.2 Flat Protocols

In flat based networks, each node has the similar configuration and each node operates together in a collaborative manner. These protocols measure the neighbor nodes cost such as residual energy, stability of the signal, etc. and computes energy efficient and reliable route for data transmission (Azzedine Boukerche (2008)). Some of the popular flat based routing protocols are gradient broadcast (GRAB) protocol (Ye, F. et al. (2005)) , sequential Assignment Routing (SAR) protocol (Ye, F et al. (2001)) , minimum cost forwarding algorithm (MCFA) (Sohrabi, K. et al. (2000)).

2.2.3 Geographical Routing

In geographical routing, each node discovers the location information of the other nodes (location aware devices) in prior and avoids the unwanted energy consumption. The main idea at the heels of geographical routing is to avoid control overhead since control overhead consumes a huge amount of network energy (Azzedine Boukerche (2008)). The protocols designed based on geographical routing are speed protocol (He, T. et al. (2003)), geographic routing with no location information (Rao, A. et al. (2003)), geographic routing with limited information in sensor networks (Subramanian, S. et al. (2005)).

2.2.4 Hierarchical Protocols

The routing technique performed in cluster based network scenario (nodes, cluster heads and the base station) is referred as hierarchical routing. Most of the hierarchical routing protocols does energy optimization. In hierarchical routing, Sensor nodes collect the physical information (environmental data), cluster head collects the physical information from sensors and transmits it to the base station. Some of the popular hierarchical routing protocols are Low-energy adaptive clustering hierarchy (LEACH) protocol Heinzelman, W. R. et al. (2000), power efficient gathering protocol (PEGASIS) Lindsey, S. et al. (2002), threshold-sensitive energy-efficient sensor network protocol (TEEN) Manjeshwar, A. et al. (2001)

2.2.5 Multi path Routing

Protocols that discover multiple routes for data transmission is referred as multi path routing, the prime objective behind the development of multi path routing is to prevent route failures and packet re-transmissions. The additional control packets that are required for single path routing is avoided in multi path routing. Link failures and re-transmissions are avoided in multi path routing. Therefore multi path routing is energy efficient and reliable (Azzedine Boukerche (2008)). Examples of multi path routing are meshed multi path routing (M-MPR) protocol (De, S. et al. (2003)), highly resilient, energy efficient multi path routing in wireless sensor networks (Ganesan, D. et al. (2001)), ReInForM (Stoica, I. et al. (1998)).

2.2.6 Energy Aware Routing Protocols

The following routing protocols are designed specifically to improve the energy efficiency of the network.

- **Ad-hoc Ondemand Distance Vector Routing (AODV)** : AODV (Adhoc on demand distance vector) is the standard flat based routing protocol that is reactive. AODV performs better in bandwidth utilization since network energy consumption is utilized efficiently. In case of route and node failures, AODV has self-healing capability (Perkins, C. et al. (2003)).
- **Low-Energy Adaptive Clustering Hierarchy (LEACH)** : LEACH is a hierarchical routing protocol that does cluster based routing process. In LEACH protocol, alternative cluster head selection is done for every round (time cycle), which maintains the uniform load distribution among nodes. This protocol does cluster head selection based on the probability of present round. LEACH is the efficient routing protocol that concentrates on energy optimization (Heinzelman, W. R. et al. (2000)).
- **Geographical and Energy Aware Routing (GEAR)** : GEAR is the energy efficient routing mechanism that does route selection, by utilizing the energy information and location information of the nodes. It selects the next hop node which is closer to the destination (Yu, Y. et al. (2001)).
- **Threshold Sensitive Energy Efficient Sensor Network Protocol (TEEN)**: TEEN is specifically designed for time sensitive network applications. TEEN ensures the data aggregation, by assigning specific time limits for cluster head selection. It is energy efficient in nature as well as it is more suitable for time sensitive applications (Manjeshwar, A. et al. (2001)).
- **Power-Efficient Gathering in Sensor Information Systems (PEGASIS)**: PEGASIS does chain based routing by considering near to optimal distance of source node. This protocol performs the route selection based on the chain information. Therefore it finds energy efficient path for data transmission (Lindsey, S. et al. (2002)).
- **Hybrid Energy-Efficient Distributed Clustering (HEED)**: HEED protocol periodically selects the cluster heads based on the residual energy information

and node degree information. In this routing mechanism nodes are assumed as quasi stationary and every node joins the appropriate clusters based on transmission cost (Younis, O. et al. (2004)).

- **Energy-Aware Routing Protocol (EARP)**: EARP is the energy efficient routing protocol that retains the information of the path, which is less likely to be expired. Therefore, the same path information can be utilized, if the communication is initiated between same nodes (Mann, R. P. et al. (2005)).
- **Cluster based Energy Efficient Routing Protocol (CBEERP)**: CBEERP is a cluster based routing protocol that does routing without the aid of routing information. This protocol is constructed in two phases: cluster formation phase and data transmission phase. In cluster formation phase, base station floods control packets for cluster head selection. Later, nodes join their appropriate clusters and start transmitting the data (Lee et al. (2005)).
- **Energy Efficient Clustering Scheme (EECS)**: EECS is energy efficient clustering protocol that does data collection in a periodic manner. It avoids control overhead and reduces network overload. In this, routing scheme cluster head is selected based on energy level of the nodes(Ye, M. et al. (2005)).
- **Energy Efficient Clustering Algorithm (EECA)**: EECA is a cluster based routing protocol that does uniform cluster head distribution in network scenario. Unwanted cluster heads are avoided by EECA routing mechanism. In this protocol control messages are broadcasted based on CSMA protocol (Kang, T. et al. (2007)).
- **Energy Efficient Dynamic clustering (EEDC)**: EEDC operates similarly to LEACH protocol. It selects the cluster heads (CH) based on residual energy level and it forms the clusters based on the distance metric, it helps to maintain balanced energy utilization (Yu, M. et al. (2007)).
- **Extending lifetime of CH (ELCH)**: ELCH is the hybrid type routing protocol that performs inter cluster communication in the multihop fashion. The ELCH is constructed based on MTE (Minimum Transmission Energy) protocol (Lotf, J. J. et al. (2008)).

- **Partition LEACH Algorithm (PLEACH):** PLEACH does effective network partitioning to achieve better network lifetime. Cluster head for every cluster is chosen based on nodes residual energy. Due to optimal network partitioning every cluster is uniformly loaded (Gou, H. et al. (2009)).
- **Improvement on LEACH Protocol (VLEACH):** VLEACH is the enhancement of LEACH protocol that keeps alternate cluster head called vice cluster head. When present cluster head fails or drains out its energy the vice cluster head acts as cluster head, therefore network lifetime will be prolonged (Yassein, M. B. et al. (2009)).
- **Energy Efficient Routing Scheme for Mobile Wireless Sensor Network (MLEACH):** The LEACH routing protocol is incorporated by including mobility features is referred as MLEACH. In MLEACH protocol all nodes are assumed to be homogeneous and location aware (Nguyen, L. T. et al. (2008)).
- **Ad-hoc On demand Distance Vector Routing - Backup Routes (AODV - BR) :** AODV-BR is the enhancement of AODV routing protocol. AODV-BR keeps backup routes and utilizes them in case of link failures, which reduces control overhead in the network (Lee, S. J. et al. (2000)).
- **Ad-hoc On demand Multipath Distance Vector Routing (AOMDV):** AOMDV selects the multiple loop free dis-joint paths for data transmission. It reduces 40 % packet loss when compared to standard AODV protocol. AOMDV also reduces end to end delay, which says AOMDV achieves energy efficiency and meets QoS requirements (Marina, M. K. et al. (2006)).
- **Enhanced Ad-hoc On demand Multipath Distance Vector Routing (EAODV):** EAODV name describes the enhanced version of AODV routing protocol . AODV floods the control packets from source to destination and stores the routing information in its cache. In EAODV, source to destination routing information is stored for selective routes, which avoids route concentration on particular sensor devices (Kim, B. C. et al. (2005)) .
- **Ad-hoc On demand Multipath Distance Vector Routing - Break Avoidance (AODV- BA):** The prime aspiration of AODV- BA design is to avoid link breakage in networks. In this protocol, intermediate nodes detect the link

breakage by up-stream packet transmission. If the link breakage is detected, then it finds the alternate link for data transmission (Tauchi, M. et al. (2005)).

- **Ad-hoc On demand Multipath Distance Vector Routing - Accessibility Prediction (AODV-AP):** AODV-AP is the extended version of AODV routing protocol that finds the stability of links and transmits the data in accessible routes (reliable path). Reliable data transmission in network avoids the uneven energy consumption (Rehman, H. U. et al. (2007)).
- **Enhanced Ad-Hoc on Demand Multipath Distance Vector Routing Protocol (EAOMDV):** EAOMDV is designed based on AOMDV protocol, it is mainly designed to avoid route failures. EAOMDV predicts the unstable links by Received Signal Strength information and finds reliable links for data transmission, which improves the energy efficiency of the network (Mallapur, S. V. et al. (2010)).
- **Ad-Hoc on Demand Distance Vector Routing Protocol - Delay Aware (AODV - D):**AODV - D is the QoS aware routing protocol that is constructed based on demand delay and bandwidth. It ensures the network QoS by monitoring network delay and managing with minimum available bandwidth (Subburam, S. et al. (2012)).

The literature survey describes the features of various routing protocols that are developed for improving the energy efficiency of the network. From the survey on energy efficient routing protocols, it is observed that many routing protocols are enhanced from LEACH (Heinzelman, W. R. et al. (2000)) and AODV (Perkins, C. et al. (2003)) efficient protocols since LEACH is the standard routing protocol that is introduced for hierarchical network scenario, where AODV is the standard routing protocol that is introduced for flat based network scenario. Many IoT applications adopt flat based network scenario, where AODV is the suitable routing protocol for flat based network scenario. Thus, we adopt AODV as an underlying routing protocol in our proposed network architecture. In proposed network architecture, features of AODV is enhanced and integrated along with node placement technique.

Table 2.1, describes the extensions of AODV routing protocol. From Table 2.1, it is understood that, enhancing a standard routing protocol with effective routing parameters can achieve application specific network requirements. In proposed network

Table 2.1: AODV Extensions

Authors	Protocol	Metric	Features
Perkins et al. (1999)	AODV	Hop-Count	Finds shortest paths
Lee and Gerla (2000)	AODV-BR	Hop-Count	Maintains backup routes
Marina and Das (2001)	AOMDV	Hop-Count	Multiple loop free paths
Kim et al. (2005)	EAODV	Hop-Count	Selective route cache
Tauchi et al. (2005)	AODV-BA	RSS, RE	Predicts link failure
Rehman et al. 2007	AODV-AP	Signalstrength	accessible routes
Mallapur and Terdal (2010)	EAOMDV	RSS	Predicts link failure
Subburam and Khader (2012)	AODV-D	Delay	Delay based routing
Proposed	Architecture	RE and ETT	energy efficient and Reliable Data Transmission

architecture, we enhanced the features of AODV routing protocol by adding residual energy and ETT information to achieve energy efficient and reliable data transfer.

2.3 ENERGY EFFICIENT NODE PLACEMENT TECHNIQUES

Node placement technique is one of the efficient technique which is developed to achieve the energy efficiency and network connectivity. This Section describes the research works carried out in node placement techniques that are developed, to improve the lifetime of the network.

(Bari, A. (2005)) has made a brief survey on relay node placement techniques, in this survey author say that implementing relay nodes in network scenario avoids uneven energy consumption and prolongs network lifetime. An energy efficient node placement technique is introduced by (Cheng, X. et al. (2008)), it elaborates the approximation schemes for efficient placement and sensor node placement where done with the perfect line of sight that prolongs the network lifetime and achieves network coverage. (Efrat, A. et al. (2005)) proposed energy efficient relay node placement technique that is modeled by Steiner Minimum Tree with the Minimum number of Steiner Points (SMT-MSP) optimization based on the NP-hard problem. This paper addresses the trade-off between the lifetime of network and cost of the network. In (Pan, J. et al. (2005)), node placement technique for cluster oriented sensor network is designed. In this technique, there are three different nodes called base-stations, sensor

nodes and application nodes. The energy efficient topology control process is implemented to optimize the communication between application node and the base station. Most of node placement techniques concentrate either on network coverage or network lifetime, where relay node placement technique proposed in (Xu, K. (2010)) improves both network coverage and network lifetime, it improves network coverage and network lifetime by introducing three node placement mechanism called as lifetime-oriented, hybrid deployment and connectivity-oriented. Node placement technique proposed in (Jie Jia et al. (2013)) describes the rational relay node density in wireless sensor networks. In this paper authors theoretically proved that varying the density of nodes in network environment rationally prevents energy hole and balances the data traffic. (Errol L. Lloyd et al. (2007)) introduced node placement technique based on the idea of minimum-per node transmission power and maximum degree in the minimum power topology. The proposed node placement technique is more suitable for flat based network scenario and it improves the network connectivity. (Koustuv Dasgupta et al. (2003)) elaborated the advantages of relay node placement in wireless Networks, they describe optimal relay node placement in sensing environment improves network connectivity and energy efficiency. (YoungSang Yun et al. (2013)) describe the major reason for energy hole occurrence and advantages of node density variation in network scenario. In this paper, density of nodes is varied, to balance the network load and energy consumption. (Xiaobing Wu et al. (2008)) proposed an effective solution for non-uniform energy utilization, authors of this paper introduced the efficient solution, by dividing whole network into multiple coronas and varying node density for each corona based on data traffic. (Muharrem Gun et al. (2007)) has done node placement technique with variable battery level nodes to prolong the lifetime of sensor network, cost model is formulated in this work to obtain effective node placement technique and to maintain energy efficiency in the network. (Bein, D. et al. (2009)) proposed three different distributed algorithms that adjust the transmission range of nodes in wireless sensor networks and prolongs the network lifetime. (Yu, Y. et al. (2011)) analyzed on non-uniform maximum transmission ranges in WSN scenario. They proposed an energy-efficient algorithm for Non-uniform Maximum Transmission range (ENMT), to obtain the suitable transmission range for every node in the network. (Zhao, E. et al. (2008)) proposed a variable transmission range adjustment scheme based on the quality coverage (EBVTC). They explained that EBVTC highly reduces the non-uniform energy consumption.

From these research works, it is understood that implementing relay node placement in network scenario plays major role in balancing network traffic. Varying the density of nodes, varying the battery levels of nodes and varying the transmission range of nodes in the network scenario, highly balances the energy consumption and prolongs the network lifetime. Therefore, we integrated both of the techniques together in proposed network architecture.

2.4 CROSS LAYER MODELS

Various optimization techniques have been introduced to improve the network lifetime in IoT Networks. Among them, cross layer design is one of the efficient technique, that integrates the features of various layers and achieves better network performance. This Section describes various cross layer designs that involve in network lifetime and reliability.

(Srivastava, V. et al. (2005)) made a survey on different cross layer models and described the features of cross layer models, in this survey authors say that, cross layer design integrates the features of various layers and satisfies specific network requirements. (Stai, E. et al. (2016)) introduced a weighted BP algorithm called weighted back pressure routing/scheduling cross layer approach, it integrates routing, scheduling, and congestion control mechanism. This cross layer model achieves better throughput and meets application requirements. In (Wang, J. (2010)) a service oriented cross layer model is proposed to prolong the network lifetime. This model estimates the number of nodes that are required to satisfy the application requirement and enhances the network lifetime. (Madan, R. et al. (2006)) proposed the cross layer design by integrating the features of routing, link scheduling and link transmission power. In this paper, network lifetime is improved with the help of the iterative algorithm that performs effective link scheduling. (Al-Jemeli et al. (2015)) introduced cross layer model that improves the energy efficiency of IEEE 802.15.4. In this paper, authors attempt to reduce the control overhead in mobile wireless sensor networks. In this model, MAC layer varies the node's transmission power concerning nodes location information. (Cammarano, A. et al. (2015)) integrated congestion/rate control protocol stack, medium access control and routing, to attain better throughput in cognitive radio ad hoc networks (CRAHNS). (Park, P. et al. (2011)) introduced cross layer protocol named as "Breath", which integrates randomized routing and medium

access control. Breath achieves balanced energy utilization and prolongs network lifetime. (Mardani, M. et al. (2012)) introduced cross layer model that integrates flow control technique, multipath routing, and random access control technique. In this paper, successive convex approximation approach is implemented for network utility maximization. (Ben-Othman, J. et al. (2010)) proposed a protocol called as EQSR (Energy Efficient and QoS Aware Multipath Routing Protocol), which does efficient energy utilization and prolongs network lifetime. EQSR involves the parameters such as, signal-to-noise ratio (SNR), interface buffer availability and residual energy, to improve the network performance. (ElBatt, T. et al. (2004)) designed a cross layer model that involves power control mechanism and scheduling mechanism. Authors describe that their model resolves multi access problem in wireless sensor networks. The major aim of this work is to eliminate interference and improve the network reliability. (Larzon, L.-A. et al. (2002)) introduced a method named as hints and notifications (HAN) that enables inter-layer communication. HAN does efficient spectrum utilization. (Ju, H. et al. (2015)) designed the cross-layer model that achieves better service assignment gains and diversity. This model achieves better throughput it in both in-elastic traffic and elastic traffic. (Alabbasi, A. et al. (2016)) proposed the cross-layer model, that achieves energy efficiency in 5G spectrum sharing environment. Authors used modified energy per good bit (MEPG) metric and generalized MEPG function for efficient spectrum utilization, to achieving balanced energy consumption. (He, S. et al. (2012)) introduced energy efficient cross layer model to enhance the network lifetime, in this paper authors integrated network layer(routing technique) and MAC layer (power control technique), to obtain link access probabilities. (Felemban, E. et al. (2010)) introduced a cross layer protocol named as Sectorized-Antenna Medium Access Control (SAMAC) protocol, which balances energy utilization and maintains transmission delay. (Shi, L. et al. (2010)) proposed cross layer model that obtains the optimum transmission power. Authors integrated the features of MAC based power control technique and routing technique to achieve energy efficiency. (Varun, M. C. et al. (2010)) designed a cross layer protocol named as "XLP", that exchanges the physical layer and transport layer information to reduce congestion in network. (Sheng, Z. et al. (2015)) extended the Representation State Transfer (REST) protocol by introducing reliable and energy management mechanism in smart devices. (Lu, F. et al. (2015)) proposed CQIC (cross-layer congestion control model) , in this paper authors predict the capability of the node by means of physical layer information exchange

between sender and receiver. Based on this prediction of nodes capability network congestion is controlled. (Liu, J. et al. (2016)) introduced a cross-layer protocol that extends One-Sided Synchronous Two-Way Ranging (OSS-TWR) algorithm to avoid network collision.

From aforementioned research works, it is seen that integrating the features of different optimization techniques in the single network model, decidedly satisfies specific network requirements. From our study, it is observed that, when information of one layer is utilized by another layer the overall network performance can be improved. Thus, we proposed a cross layer models that integrates the features of network layer and data link layer. In proposed network models routing technique and MAC based power control technique are effectively integrated, to prolong the network lifetime.

2.5 SUMMARY

- Some of IoT applications are implemented in hostile environment (environmental monitoring) and critical monitoring purpose (e-health), therefore designing energy efficient network architecture is the major requirement in hostile network environment. Energy efficiency can be achieved by incorporating the energy metric in various layers.
- In physical layer, node placement technique would assure balanced data traffic. In data link layer, efficient power control mechanism can assure balanced energy utilization. In network layer, the route establishment takes care of the energy metric, to guarantee energy efficient path computation. Cross layer design is one of the effective techniques to achieve better network lifetime. Many algorithms and protocols were developed in the literature for the same.
- In this Chapter, a detailed literature survey on node placement technique, routing technique and cross layer design has been done. It has been seen from the results of previous works that the energy efficiency of the Network can be improved by using an appropriate routing technique, node placement technique and efficient cross layer design. Thus, in Chapter 3, 4 and 5, an attempt has been made in proposing routing and node placement integrated network architecture and cross layer designs.

Chapter 3

ROUTING AND NODE PLACEMENT INTEGRATED NETWORK ARCHITECTURE FOR LOW POWER IOT NETWORKS

Outline of the Chapter

- Section 3.1 gives a gist of the importance of energy efficiency and reliability for low power IoT networks.
- In Section 3.2, an energy efficient and reliable network architecture has been proposed and presented.
- Network architecture proposed in Section 3.2 is enhanced and explained in Section 3.3.
- Network architectures proposed in Section 3.2 and Section 3.3 is further improvised and presented in Section 3.4.
- An insight on the performance evaluation of proposed network architectures are carried out in Section 3.5
- Section 3.6 presents the concluding remarks of this chapter.

3.1 INTRODUCTION

The network that enhances the lifetime of IoT devices and maintains the reliable communication among IoT devices can be specified as the desirable network for IoT applications. Internet facilitated battery sourced devices (IoT devices) are the elementary part of low power IoT networks. IoT devices are restricted by the power source, the transmission medium used to link IoT devices are low frequency radio links, which exhibit dynamic changes in link quality. Providing reliable and energy efficient data transfer in IoT network environment is the challenging task. This enabled us to focus on energy efficient techniques to optimize the performance of low power IoT networks. Balancing the data traffic, avoiding uneven energy utilization and transmitting data in reliable links can optimize the communication unit of the network. But achieving all these objectives with the help of single optimization technique will increase the complexity of the optimization technique. Thus, we introduced the network architectures that unifies the features of node placement technique and routing technique in single network architecture and achieves the above-mentioned objectives. In node placement technique the data traffic is balanced by varying density (Bari, A. (2005), Xu, K. (2010), Jie Jia et al. (2013), Errol L. Lloyd et al. (2007), Koustuv Dasgupta et al. (2003)) of nodes and effective routing mechanism is proposed to find energy efficient and reliable path for data transmission. Node placement is implemented in network set-up phase, where as routing is implemented in network initialization phase. The following Section elaborates the overall features of proposed network architectures.

3.2 NODE PLACEMENT AND ROUTING INTEGRATED NETWORK ARCHITECTURE

Node placement technique is one of the acclaimed techniques to balance the data traffic (Cheng, X. et al. (2008), Efrat, A. et al. (2005), Pan, J. et al. (2005), Yu, Y. et al. (2011)). Similarly, in many research work it is described that routing technique (Azzedine Boukerche (2008), J. L. Gao (2010), Intanagonwiwat et al. (2000), Ye, F et al. (2001), Rao, A. et al. (2003), Heinzelman, W. R. et al. (2000), Ganesan, D. et al. (2001), Yu, Y. et al. (2001)) can gratify the network requirements such as energy efficiency, reliability, QoS etc. Therefore, to make use of these two techniques in single network architecture, we unified both routing mechanism and node placement

technique in our proposed work. By the aid of node placement technique, node density is differentiated in accordance with data traffic. In routing technique, standard routing protocol is enhanced (Marina, M. K. et al. (2006), Kim, B. C. et al. (2005), Tauchi, M. et al. (2005), Rehman, H. U. et al. (2007), Mallapur, S. V. et al. (2010), Subburam, S. et al. (2012)) by adding energy and reliability related parameters, for stable and energy efficient path selection. Figure 3.1, describes the basic concept of proposed network architecture.

Three different phases are involved in proposed network architecture.

- **Network setup phase (Node Placement Technique)** – Assuming the whole network as disk space and dividing it into various rings and deploying nodes with respect to data traffic.
- **Routing Phase (Routing Technique)** – control packet transmission and reception and path computation process by nodes.
- **Data Transmission Phase** – Transmitting data from Source to the destination.

In the network setup phase, node placement technique is performed and in network initialization phase, routing technique is performed.

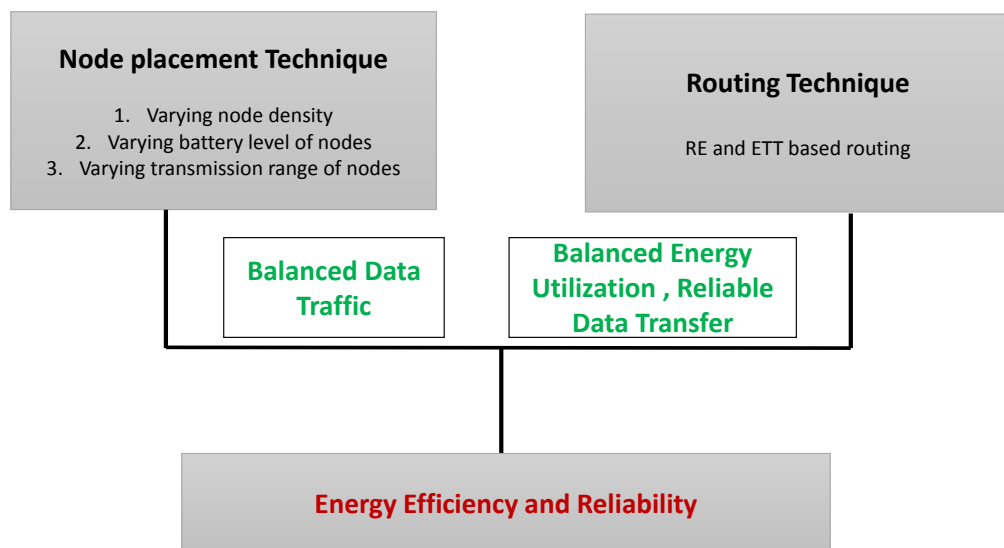

Figure 3.1: Basic idea of proposed network architecture

In our network scenario, two different types of nodes called sensor node and relay node are included. Sensor nodes do sensing and relay gathers the sensed data from sensors and shares it with base station. Sensor node does only sensing, where as relay node governs only communication of the network, therefore sensor nodes are free from path computation and really nodes are free from sensing. Relay nodes concentrates only on communication unit and improves the energy efficiency and reliability of the network (Xu, K. (2010), Jie Jia et al. (2013), Errol L. Lloyd et al. (2007), Koustuv Dasgupta et al. (2003)). The following sub section describes the overall features of proposed network architecture.

3.2.1 Network Parameters

Before moving to network architecture description, we list the network parameters which gives the clarity of proposed network architecture.

The parameters that help better understanding of proposed network architecture is listed in Table 3.1

3.2.2 Energy Model

Specifications of energy consumption model is the prime reference for network construction. The energy model adopted here is first order radio model Heinzelman, W. R. et al. (2000). The energy that is needed for transmitting k-bit data at a specific distance d is referred to,

$$E_{tx}(k, d) = \mu + \delta d^x \quad (3.1)$$

μ is the required energy for operating the transceiver circuit. δ is the required energy for enabling the transmitter amplifier to send k bit data, where x is referred to path loss exponent, x can be adjusted from 2 to 6. Likewise the required energy for receiver operation is referred to,

$$E_{rx}(k, d) = \mu \quad (3.2)$$

μ is the energy consumed by transceiver circuit. Normally the energy consumed by the receiver circuit depends only on the no of messages that are received.

Table 3.1: Network Parameters

$E_{tx}(k, d)$	The energy required to transmit k-bit message (data unit) over the distance (d).
$E_{rx}(k, d)$	the energy consumed to receive k-bit message (data unit) over the distance (d).
μ	The energy required to run the transceiver circuit.
δ	The energy required for the transmitter amplifier to transmit k bit data.
h	Total number of rings.
R_i	Ring i.
A_i	Area of ring.
ρ_i	Node density.
λ	Battery cost of nodes.
τ	Transmission range for nodes.
N	Number of the nodes.
T_i	Amount of data traffic in a ring.
E_i	Energy consumption in a ring.
C_i	Cost of the node in a ring.
RE	residual energy of the node.
ETX	expected transmission count of particular link.
ETT	expected transmission time of particular link.
α	weight assigned for RE.
β	weight assigned for ETT.
WF	weight factor defined for route discovery process.

3.2.3 Node Placement Technique - Node Density Variation

Among several energy optimization techniques, node placement technique is the notable technique that promotes the energy efficiency of the network. From literatures (Bari, A. (2005), Xu, K. (2010), Jie Jia et al. (2013), Errol L. Lloyd et al. (2007), Koustuv Dasgupta et al. (2003), Xiaobing Wu et al. (2008), Muharrem Gun et al. (2007), Bein, D. et al. (2009), Yu, Y. et al. (2011)) it is noticed that network level challenges such as energy efficiency, network connectivity, cost of the device, lifetime and latency

can be achieved by effective node placement technique. Therefore, effective relay node placement is implemented in proposed network architecture, by varying the density of nodes.

The following description helps to understand the features of flat based network scenario and node placement technique used in proposed network architecture. The network scenario is assumed as disk shape (Gun, M. et al. (2007)). The whole disk shaped network environment is sub-divided in several rings, ring 1 to ring h (from the base station to the last ring). Incoming data traffic and energy consumption of nodes in particular ring (ring i) is derived, which can be assumed for all other rings. The notions that help to understand the following description is briefed in Table 3.1.

The number of nodes present in ring i can be referred to N_i .

Data traffic handled by nodes present in ring i can be defined as,

$$T_i = N_i(k) + \sum_{s=i+1}^h N_s(k) \quad (3.3)$$

In equation (3.3), k refers the unit message (number of bits), where $N_i(k)$ denotes the unit message created from ring R_i , similarly unit message forwarded from ring R_h to ring R_{i+1} is denoted as $N_s(k)$. From the equation (3.3), traffic handled by the nodes that are placed in ring 1 and traffic handled by nodes that are placed in ring h can be defined as,

$$T_1 = N_1(k) + \sum_{s=2}^h N_s(k), \dots T_i = N_i(k) + \sum_{s=i+1}^h N_s(k) \dots T_h = N_h(k) \quad (3.4)$$

From equation (3.3) and equation (3.4), it is seen that data traffic from ring h to ring 1 gradually increases, which says nodes deployed near to base station holds the data traffic generated by whole network.

$$T_1 > T_2 > T_3 > \dots T_i > T_{i+1} > \dots T_h \quad (3.5)$$

From the aid of equation (3.1) and (3.2), the energy required to transmit and receive the data for nodes present in the ring R_i can be defined as,

$$E_{ci}(Total) = k(\mu + \delta d^x)N_i + \sum_{s=i+1}^h k(\mu + \delta d^x)N_s + \sum_{s=i+1}^h [k(\mu)]N_s \quad (3.6)$$

From equation (3.6), we can say that energy required to transmit and receive the data for nodes present in the ring Rh is defined as,

$$E_{ch}(Total) = [k(\mu + \delta d^x)]N_h \quad (3.7)$$

Similarly, energy required to transmit and receive the data for nodes present in the ring R1 is defined as,

$$E_{ci}(Total) = k(\mu + \delta d^x)]N_i + \sum_{s=1}^h k(\mu + \delta d^x)]N_s + \sum_{s=1}^h [k(\mu)]N_s \quad (3.8)$$

From equation (3.6), (3.7) and (3.8), it is observed that, nodes present near the base station consumes huge amount of energy when compared to other nodes in the network.

$$E_{c1} > E_{c2} > E_{c3} > \dots\dots\dots E_{ci} > \dots\dots\dots E_{ch} \quad (3.9)$$

From equation (3.5) , it is noticed that the data traffic increases from ring Rh to R1. Similarly, from equation (3.9), it is seen that nodes near to base station consumes huge amount of energy, which says the chance of un balanced data traffic and non-uniform energy consumption is more in flat based network scenario. Therefore, to avoid energy hole issue, number of nodes (node density) can be increased towards the base station.

$$\rho_1 > \rho_2 > \rho_3 \dots\dots\dots > \rho_i > \dots\dots\dots > \rho_h \quad (3.10)$$

Node density variations can balance the data traffic and improve the energy efficiency of the network . In our network scenario, we divided the whole network in to seven rings and based on incoming data traffic of every ring, density of nodes are varied (Bari, A. (2005), Xu, K. (2010), Jie Jia et al. (2013), Errol L. Lloyd et al. (2007), Koustuv Dasgupta et al. (2003)). The area of the whole network environment is 382 meters diameter and 191 meters radius. The whole network environment is considered as disk space and it is sub divided into seven rings. In the network scenario, sensor nodes and relay nodes are deployed. Sensor nodes are deployed in a random manner, where relay nodes are deployed in planned way (node placement technique), because deploying the nodes in planned way regulates the data traffic and prevents energy hole occurrence. In the network scenario, relay nodes near to base station hold huge data

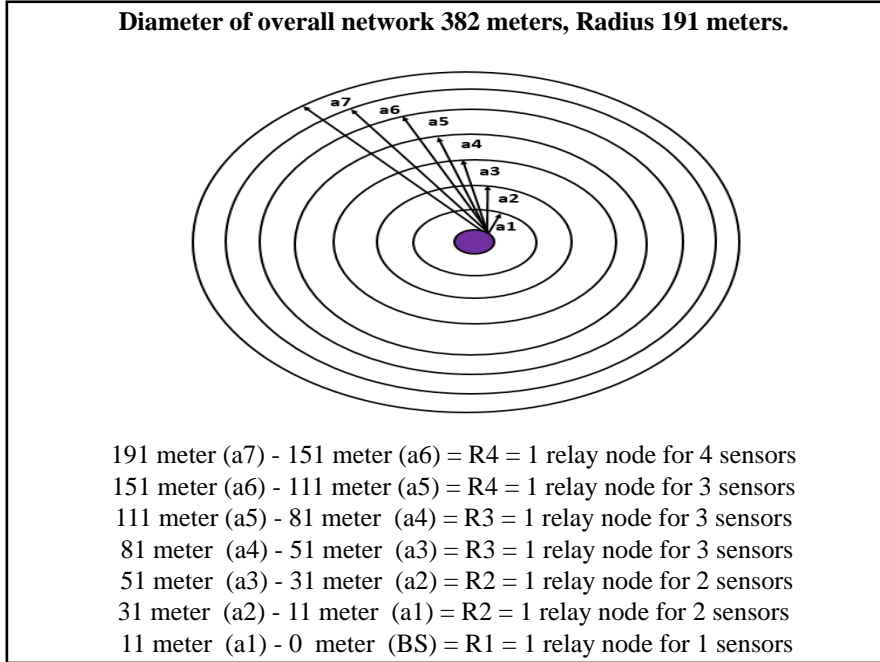

Figure 3.2: Specifications node density variations

traffic and relay nodes far from base station hold less data traffic, thus we increased the density of relay node near to the base station. In last ring (7th), for every four sensor nodes one relay node is assigned since they hold less data traffic. In 6th, 5th and 4th ring, for every three sensor nodes one relay node is assigned, since they hold medium data traffic. In the 3rd and 2nd ring, for every two sensor nodes one relay node is assigned, since they hold high data traffic. In first ring(1st), for every sensor node one relay node is assigned, since they hold very high data traffic. Figure 3.2, describes the specifications of nodes density variations.

3.2.4 Routing Technique

In any kind of network, routing plays an extensive role in achieving application specific network objectives. Optimizing routing technique determinedly improves the energy efficiency and reliability of the network. Thus we proposed an energy efficient routing mechanism and included in proposed network architecture. From literatures (Lee, S. J. et al. (2000),Marina, M. K. et al. (2006),Kim, B. C. et al. (2005),Tauchi, M. et al. (2005),Rehman, H. U. et al. (2007), Mallapur, S. V. et al. (2010),Subburam, S. et al. (2012)) it is seen that enhancing standard routing protocol by including effec-

tive parameters highly promotes the network performance. Hence, in proposed work, parameters such as Residual Energy (RE) and Expected Transmission Count (ETX) (De Couto, D. S. et al. (2005)) is included in standard AODV routing protocol. With the help of RE and ETT information, energy efficient and reliable path computation is performed.

Residual Energy : Monitoring the energy level of nodes in network operation time, obtains uniform energy utilization. Residual energy is recognized as one of the fundamental parameters to balance the energy utilization. Residual energy based routing can avoid energy hole issue. Residual energy is defined as,

$$RE = \frac{Er}{Emax} \quad (3.11)$$

Er is the available energy of the node, $Emax$ is the maximum energy level of the node.

Expected Transmission Count : Expected transmission count (ETX) is the efficient parameter that improves the reliability of the network. Multi-retransmissions is the pivotal issue that need to be taken care in IoT networks since multi re-transmissions decidedly affects the network reliability. Therefore, including ETX in routing mechanism of proposed network architecture can resolve multi-retransmission issue. ETX identifies the link stability by measuring the forward packet delivery ratio and reverse packet delivery ratio of the link. ETX (De Couto, D. S. et al. (2005)) of a link is calculated as,

$$ETX = \frac{1}{D_f \times D_r} \quad (3.12)$$

Expected transmission count (ETX) is the routing metric that calculates the MAC transmissions and retransmissions and obtains the frame losses caused by channel issues. Estimation of the average number of transmissions of data frames and ACK frames necessary for the successful transmission of a packet in the wireless link is referred to ETX. Every node in the network measures the ETX by estimating the frame loss ratio at a particular link in the forward direction (D_f) and in the reverse direction (D_r), based on this estimation reliability of particular link is measured. D_f refers the forward packet delivery ratio and D_r refers the reverse packet delivery ratio.

3.2.5 Weight Factor Calculation

Weight factor value is the combination of RE and ETX information. In network initialization phase, routing will be initiated and every node starts flooding control packets (transmitting and receiving route request and route reply control packet). At the end of flooding process, every node receives RE and ETX information and they compute weight factor (WF) value by using weighted sum approach. The weight factor value is calculated as follows,

$$WF = \alpha \left(\frac{RemainingEnergy}{MaximumEnergy} \right) + \beta \left(1 - \frac{ETX}{MaximumETX} \right) \quad (3.13)$$

Initially, the RE and ETX information is included in control packet options and it will be flooded throughout the network (sending route request packet RREQ). In the final stage of routing phase, the control packets that consist of RE and ETX information will be received by every node in the network (receiving route reply packet RREP). Based on the RE and ETX information every node computes the path for data transmission path. Equation (3.13) represents the calculation of WF value, adding RE and ETX information in control packets of the routing protocol, enables the RE and ETX based routing. Therefore, by utilizing the WF value every node achieves energy efficient and reliable data transmission. In equation (3.13), α and β values are scaled from (0 to 1).

Priority of the parameters can be chosen based on network requirements. For example, if we need to give more priority for ETX. 0.4 can be chosen for RE and 0.6 can be chosen for ETX, such that total sum will be $(0.6 + 0.4) = 1$. Figure 3.3, describes the control packet structure of proposed routing mechanism.

3.2.6 Route Selection by Destination Node

For understanding the path computation process in proposed network architecture, let us consider the functions of the source node (X) and one destination node (Y).

Path computation Process

- *Step 1: Start*
- *Step 2: Initially Source node (X) floods route request packet in the network.*

Type	Flags	Reserved	Hop count
RREQ (broadcast) ID			
Destination IP Address			
Destination Sequence Number			
Original IP Address			
Original Sequence number			
Residual Energy and Expected Transmission Time			

Figure 3.3: Control packet structure of proposed network architecture

- *Step 3: When the route request packets (RREQ) reaches the destination node (Y), it computes the path with high Weight Factor (WF) value (high residual energy and low ETX).*
- *Step 4: Destination node (Y) compares WF value among various paths.*
If
WF value is high: Insert Route Request Cache and Update route entry.
else
Discard route request packet.
- *Step 5: Destination node (Y) transmits the route reply packet (RREP) to the source node, that contains energy efficient and reliable path information.*
- *Step 6: Source node (X) transmits the data to the destination node (Y) in energy efficient and reliable path.*
- *Step 7: Stop.*

The above steps are detailed in Figure 3.4.

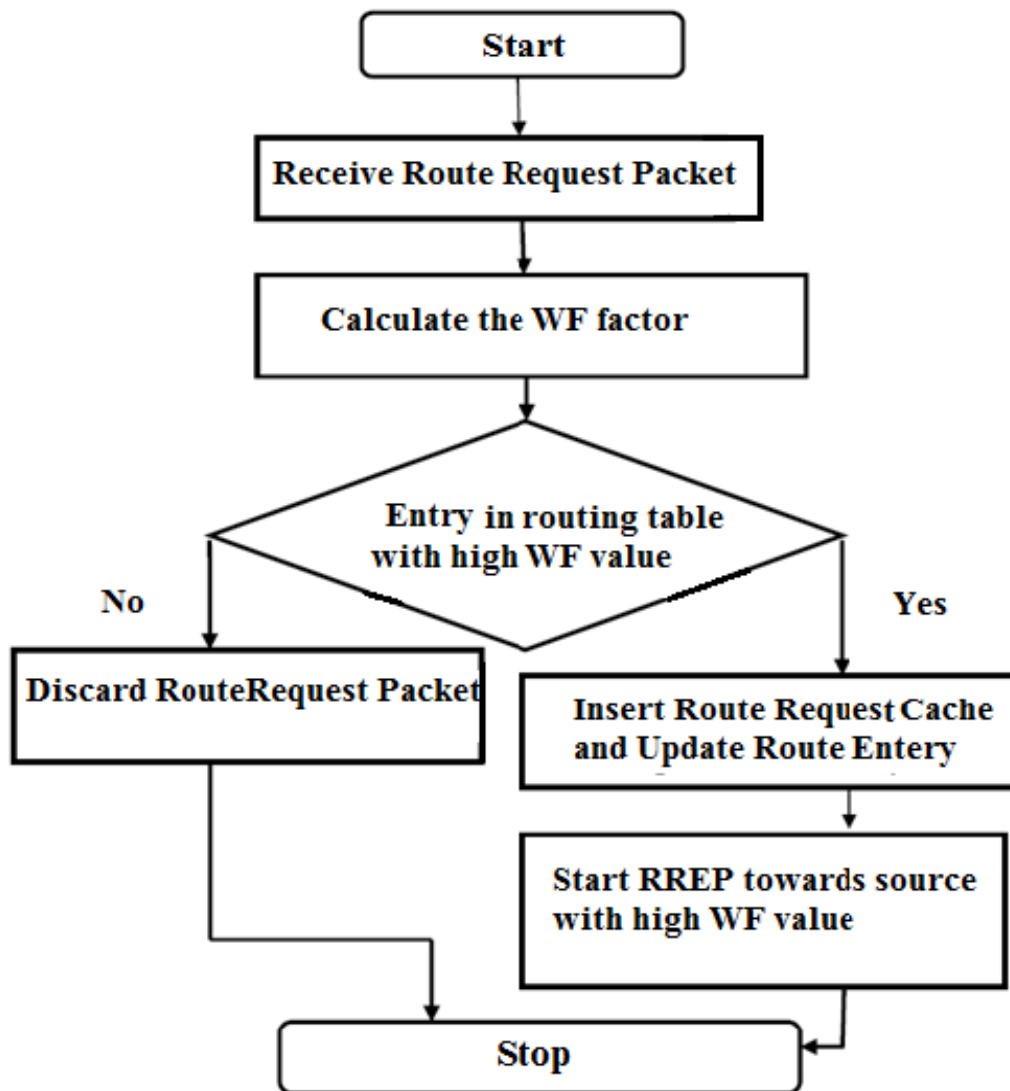

Figure 3.4: Route selection process used for proposed network architecture

Path selection procedure by destination nodes is explained in Figure 3.4. Selecting route with high residual energy and low ETX assures energy efficient and reliable path, which shows that proposed network architecture balances data traffic (node placement technique) and finds energy efficient and reliable path for data transmission (routing technique).

In proposed network architecture, routing technique and node placement technique are efficiently integrated to achieve better network lifetime. In node placement technique, node density is varied to balance the data traffic and with the help of routing

technique energy efficient and reliable path is computed for data transmission. From results and analysis, which is described in Section 3.5, it is understood that proposed network architecture (Section 3.2) outperforms standard network model (AODV and IEEE802.15.4).

Increasing the node density towards the base station is the effective solution to achieve uniform data traffic and balanced energy consumption. But increasing node density increases the implementation cost, as well as it decidedly increases the control overhead for nodes that are placed near to base station. Based on the trace file data generated in NS-2, we can say that node density increases the control overhead.

- Node placement Technique (Node Density Variations) – 72032 control packets are generated in 2000 seconds.
- Node placement Technique (Battery level Variations) – 44320 control packets are generated in 2000 seconds.
- Node placement Technique (Transmission range Variations) – 42345 control packets are generated in 2000 seconds.

Similarly, in routing technique, the parameter that avoids inter flow interference and intra flow interference need to be avoided. Therefore, to overcome these issues (control overhead, implementation cost, inter flow interference and intra flow interference) an efficient network architecture is proposed and presented in Section 3.3.

3.3 ROUTING AND NODE PLACEMENT INTEGRATED NETWORK ARCHITECTURE WITH BATTERY LEVEL VARIATION

Energy is one of the valuable resources in IoT network. Energy efficient network architecture that improves energy efficiency and network reliability is proposed initially (Section 3.2). Although the proposed network architecture seems to outperform standard model (standard AODV + IEEE 802.15.4) (Perkins, C. et al. (2003), Callaway, E. et al. (2002)) in terms of network lifetime. Control overhead and implementation cost also need to be taken care to obtain energy efficiency. Similarly, parameter that avoids interflow interference and intraflow interference need to be considered. This

motivated us to design the network architecture that holds variable battery level nodes in the network scenario . Energy model and network model is adopted from network architecture introduced in Section 3.2.3 The overall features of proposed network architecture is described in following Sections.

3.3.1 Node Placement Technique - Battery Level Variation

The prime objective of proposed network architecture is to avoid control overhead and implementation cost. The dis-advantage in increasing node density is the cost of network increases. It increases the control overhead to the nodes, that are placed near to the base station. To reduce the implementation cost and control overhead, we adopt the cost model from (Muharrem Gun et al. (2007)). Network cost can be defined as,

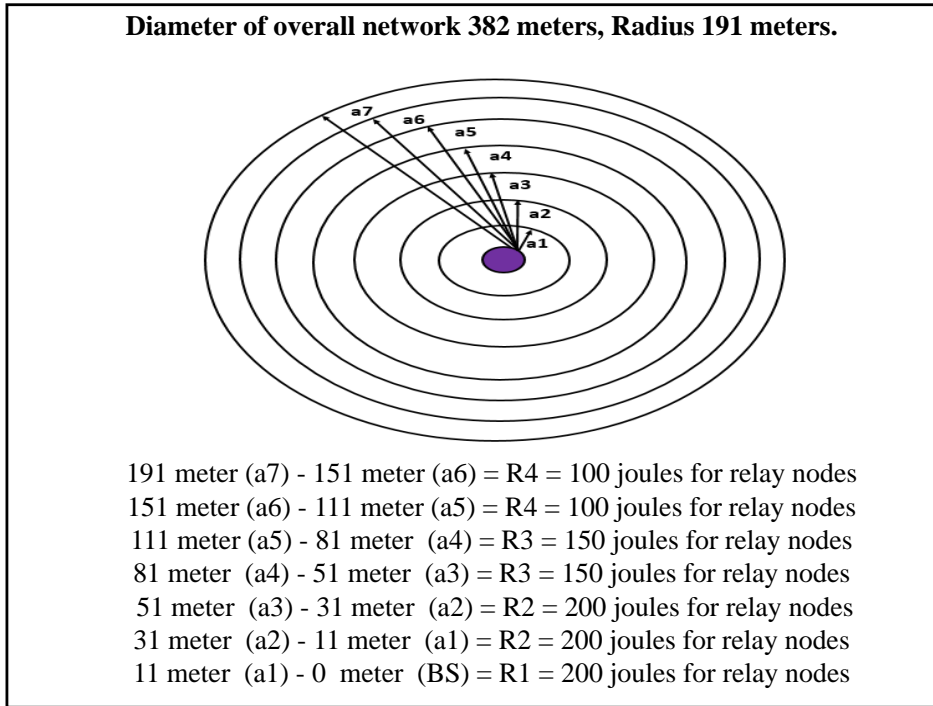

Figure 3.5: Specifications of battery level variations

$$C = \sum_{S=1}^h [\tau + \lambda(E_c)]N_s \quad (or) \quad C = \sum_{S=1}^h [\tau + \lambda(T)]N_s \quad (3.14)$$

From equation (3.14) the battery cost of node in ring Ri can be referred as,

$$C_i = \sum_{S=1}^h [\tau + \lambda_i(T_i)]N_s \quad (3.15)$$

" τ " refers the hardware cost, " λ " refers the battery cost, T_i refers the traffic in ring i , C_i refers the cost of node in ring i , N_s is the number of nodes present in ring i . In equation (3.15) cost of the hardware " τ " is kept constant, which reduces the implementation cost, By considering the (3.15) and (3.16) only the battery cost of the nodes can be varied from ring R_1 to R_h ,

$$\lambda_1 > \lambda_2 > \lambda_3 > \dots\dots\dots\lambda_i > \dots\dots\dots\lambda_h \quad (3.16)$$

By seeing equation (3.5), (3.9), (3.15) and (3.17), we can say deploying nodes with variable battery levels can balance the data traffic and it can reduce the implementation cost and control overhead. Therefore, deploying the nodes with variable battery level can be the suitable approach for low power IoT networks. Figure 3.5, describes the specifications of battery level variations. The whole network space is of 382 diameters, which is divided into seven concentric rings.

3.3.2 Routing Mechanism

Routing mechanism, implemented in proposed network architecture is similar to the routing mechanism proposed in Section 3.2. In proposed network architecture, the parameter called expected transmission count (ETX) (De Couto, D. S. et al. (2005)) is replaced by expected transmission time (ETT) (Javaid, N. (2010)) (expected transmission time) to avoid inter flow interference and intra flow interference.

Expected Transmission Time : Multi retransmissions is the major reason for un-even energy consumption and quick node drain out. Data transmission through unstable links increases the packet loss and network re-transmissions. Identifying reliable links by effective link measurement technique can reduce the number of retransmissions. Expected transmission time (ETT) is effective routing metric that estimates link quality based on ETX and link bandwidth. By the help of ETT metric the loss ratios of links can be calculated and data transmission through un stable links are prevented. Expected transmission count is the basic idea that helps to avoid retransmissions, were ETT is the upgraded version of ETX, ETX is described in the equation (3.12). Expected Transmission Time (Javaid, N. (2010)) is defined as,

$$ETT = ETX \times t \quad (3.17)$$

$$ETT = ETX \times \frac{LF}{BL} \quad (3.18)$$

$$ETT = ETX \times \frac{LF}{\frac{LL}{TS-TL}} \quad (3.19)$$

LF is referred to the data packet of fixed-size, the bandwidth of link L is defined as BL, LL refers data packet of largest-size, TS, TL refers to the interval between the arrivals of two packets. The main feature of ETT is it adjusts ETX value based on dynamic link variations and allows variable packet sizes. ETT avoids intra-flow interference and achieves better throughput by measuring loss rate and bandwidth. Thus, ETT is included in proposed routing mechanism. Route selection process of proposed architecture is similar to the routing mechanism proposed in Section 3.2.

In the initial work, density of nodes are increased towards base station. By increasing node density towards the base station uniform data traffic and balanced energy consumption can be achieved. The major drawback of increased node density is it increases the implementation cost, as well as it increases control overhead. To overcome this issue, node deployment is done with variable battery levels (with respect to data traffic) in proposed network architecture. In routing technique, ETX (De Couto, D. S. et al. (2005)) is replaced by ETT (Javaid, N. (2010)) (expected transmission time) to avoid inter flow interference and intra flow interference.

Replacing battery level of nodes reduces control overhead. But deploying nodes with variable battery level in harsh environment is difficult task and designing nodes with variable battery level increase the design complexity . Therefore, to resolve this issue the network architecture, that handles nodes with variable transmission range is proposed and presented in Section 3.4.

3.4 ROUTING AND NODE PLACEMENT INTEGRATED NETWORK ARCHITECTURE WITH TRANSMISSION RANGE VARIATION

Balanced energy consumption and reliable data transfer are the major requirements for low power IoT networks. In IoT and WSN applications, replacing battery often and non reliable data transmission severely affects the end-user as well as service provider. Based on this understanding, a energy efficient and reliable network architecture is proposed and explained in Section 3.2. The architecture proposed in Section 3.2. balances data traffic and does balanced energy utilization, but it experiences huge control overhead and high implementation cost. To avoid control overhead and to reduce implementation cost, the network architecture that varies battery level of nodes is proposed in Section 3.3. Deploying nodes with variable battery levels avoids control over head, but it increases design complexity. Therefore, to overcome these issues that occur in aforementioned network architectures, we implemented node placement technique by varying the transmission range of nodes (Bein, D. et al. (2009), Yu, Y. et al. (2011), Zhao, E. et al. (2008)). This Section describes the overall features of node placement (variable transmission range) and routing technique integrated network architecture. The major aim of proposed network architecture is to achieve energy efficiency and reliability, by avoiding issues such as unbalanced data traffic, unbalanced energy consumption and non-reliable data transmission. The physical layer (node placement technique) and network layer (routing technique) are optimized in proposed network architecture.

3.4.1 Node Placement Technique - Transmission Range Variation

The major aim of proposed network architecture is to prolong the network lifetime and achieve reliable data transfer. Energy model and network model of proposed network architecture is adopted from architecture presented in Section 3.2. Varying the density of nodes exhibits huge control over head and varying the battery level of nodes influences the design complexity. Therefore, to avoid these issues we vary the transmission range of nodes, in our node placement technique. The following conditions are assumed to vary the transmission range of nodes. Therefore in network

setup phase, nodes transmission range (communication range) is varied by adjusting receiving (RX) threshold (the minimum receive signal level the link will work with) and Carrier sensing (CS) threshold (carrier sensing range of the node to sense the senders transmission) (Correia, L. H. et al. (2007), Jung, E.-S. et al. (2002)). Following assumptions are adopted to vary the transmission range of nodes

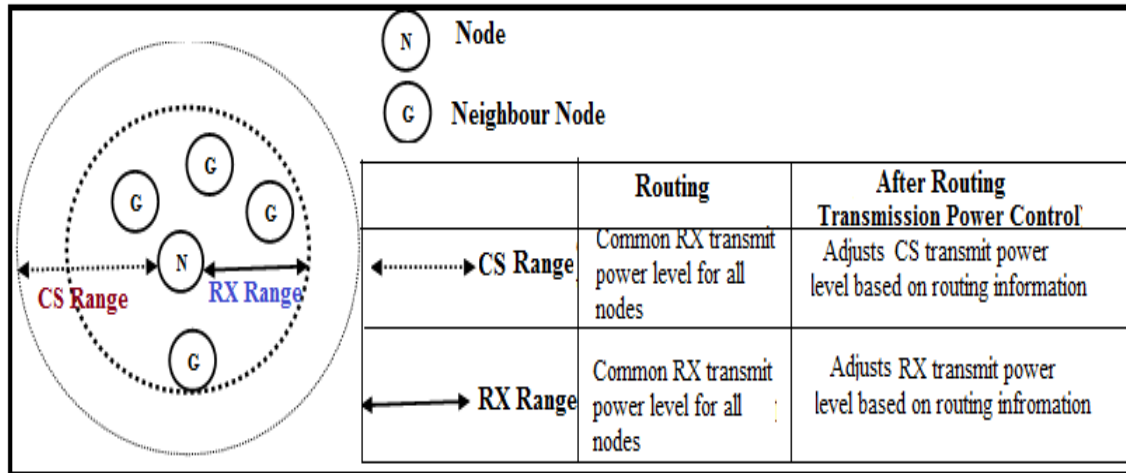

Figure 3.6: MAC based power control technique used for proposed network architecture

$$R_{min} \text{ (CS and RX min power level)} < R \text{ (Adjusted transmission range)} < R_{max} \text{ (CS and RX max power level)}$$

R_{min} is the minimum transmission range(transmit power level) of node, R is the adjusted transmission range based on the data traffic area and R_{max} is the maximum transmission range of node. R_{min} is the minimum power level of nodes and it also refers to minimum power level thresholds of carrier sensing (CS) and receiving (RX). R_{max} is the maximum power level of nodes and it also refers to maximum power level thresholds of carrier sensing (CS) and receiving (RX). In our network environment, communication range (CS and RX threshold ranges) of nodes deployed near to base station is decreased and communication range(CS and RX threshold ranges) is increased for nodes that are deployed far from base station. Figure 3.6, describes the features of MAC based power control technique.

Network connectivity is assured by adopting following condition.

$$2 R_c(\text{communication range}) > R_s(\text{Sensing range})$$

Width of ring i is defined as $w_i \text{ (meters)} = a_{i+1} \text{ (radius of } i+1 \text{ ring)} - a_{i-1} \text{ (radius$

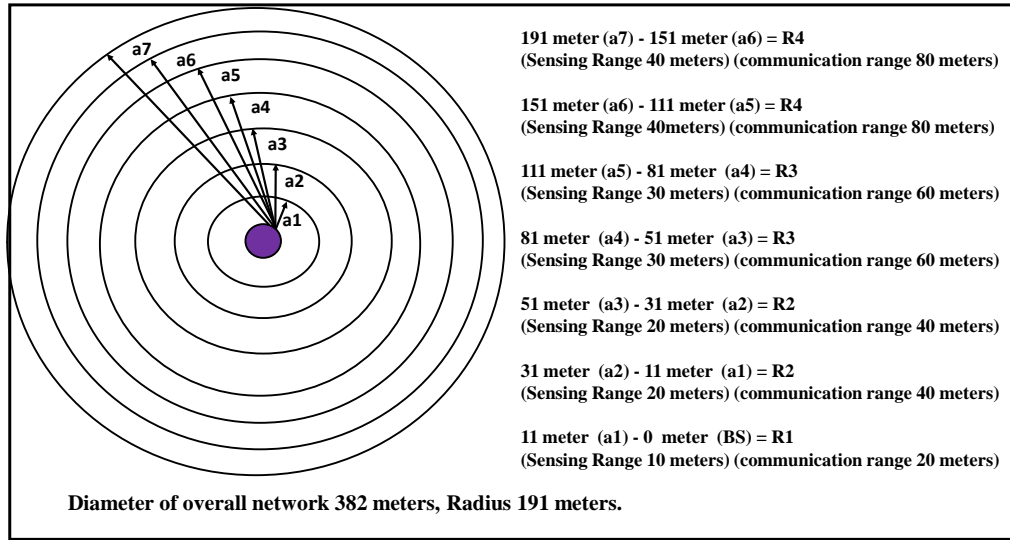

Figure 3.7: Specifications of transmission range variations

of $i-1$ ring).

a_{i+1} is the radius of previous ring and a_{i-1} is the width of the next ring. For example, if we need to calculate the width of ring 4, the radius of ring 5 should be subtracted from the radius of ring 3. The connectivity of the network can be assured only if the width of the ring (meters) should be equal to transmission range (meters) of the nodes and communication range should be twice greater than the sensing range of the nodes. For example : If the width of the ring is 20 meters, the sensing range should be 20 meters and communication range should be 40 meters.

Figure 3.7, describes specifications of various transmission range variations. The diameter of network scenario is 382 meters. Transmission range of every node is varied with respect to width of the rings. Routing mechanism implemented for proposed network architecture is similar to routing mechanism proposed in Section 3.3.

3.4.2 Blue Print of Proposed Network Architectures

IoT applications are operated by data acquisition boards and sensor nodes. To attain similar scenario in our network model, we assume sensor node as sensor devices and relay node as data acquisition board. The proposed network architecture is designed with the help of protocols such as, IEEE 802.15.4 radio (MAC and PHY) and Ipv6 protocol (Ipv6 module), which are suitable protocols to handle IoT applications.

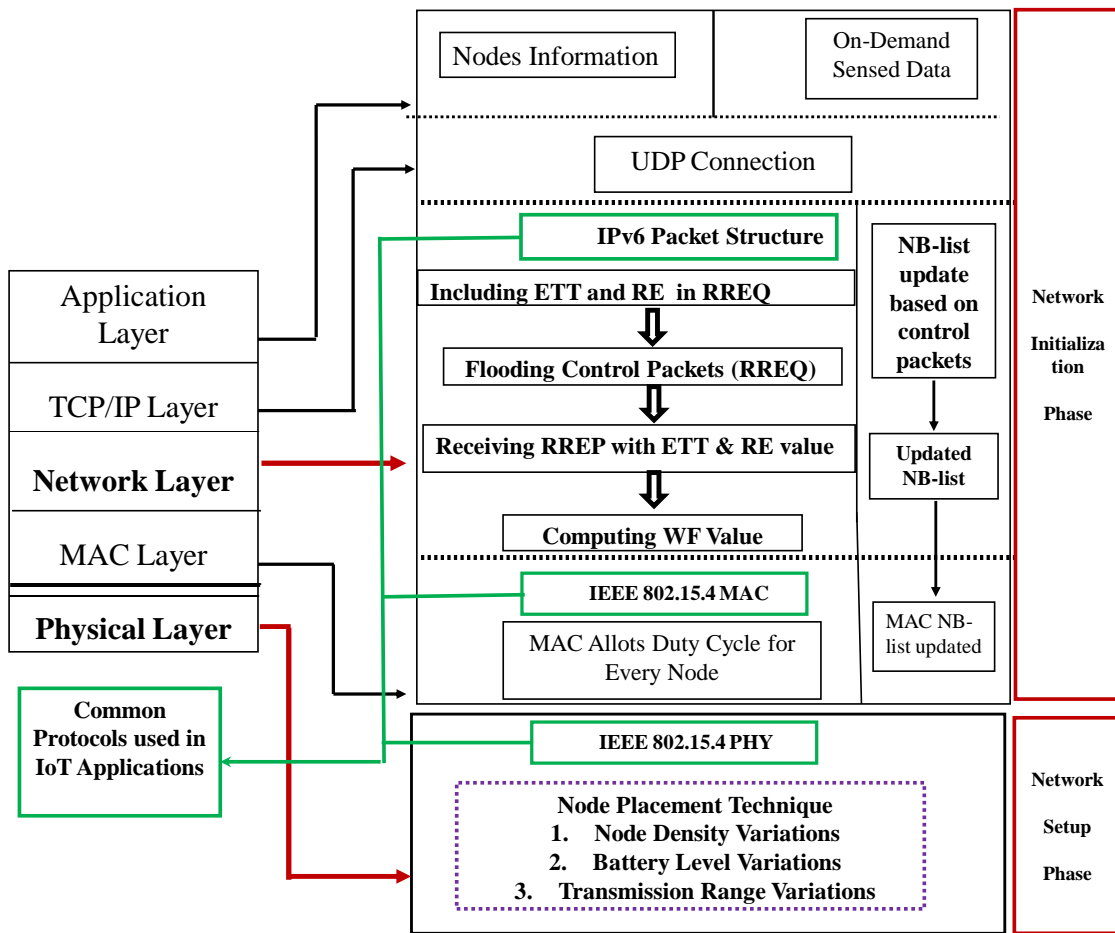

Figure 3.8: Blue print of proposed network architecture

Therefore, sensor node and relay node deployment with IoT related protocols brings the IoT scenario in proposed network architecture. Blue print of proposed network architectures is described in Figure 3.8.

The proposed network architecture overcomes various issues and prolongs network lifetime. In proposed routing and node placement integrated network architecture, data traffic, energy consumption and reliable data transfer is taken care to enhance the lifetime of low power IoT devices. From results presented in Section 3.5, it is understood that proposed network architecture outperforms standard model and the network architecture proposed in Section 3.2 and Section 3.3. Hence it is concluded that proposed network is energy efficient and reliable in nature.

3.5 SIMULATION RESULTS AND PERFORMANCE ANALYSIS

This section describes the basic assumptions of network scenario, simulation parameters and results. NS-2.34 (Network Simulator version 2.34) is used to perform simulations and Ubuntu operating system is used for NS-2 installation. IPv6 Module (Deering, S. E. et al. (1998)) is patched with NS 2 and IEEE 802.15.4 PHY/MAC radio (Marandin, D. et al. (2009)) is used.

3.5.1 Basic Assumptions

- In the network scenario, stationary nodes are deployed.
- Relay nodes are assumed as the source nodes, Sensor nodes and relay nodes are placed in the random fashion.
- Sensor nodes and relay nodes are restricted by battery, where as base station is not restricted by battery, Nodes are aware of routing metrics (RE and ETT).

To understand the performance analysis of proposed architectures in a better way, we have evaluated network architectures in six different network scenarios.

- Network Scenario 1 (NS1) - Standard model (IEEE 802.15.4 + AODV protocol)
- Network Scenario 2 (NS2) - EQSR protocol
- Network Scenario 3 (NS3) - Implementing only node placement technique without including proposed routing technique (only AODV is used without including RE and ETT).
- Network Scenario 4 (NS4) - Implementing only routing technique without including node placement technique.
- Network Scenario 5 (NS5) - Proposed network architecture that integrates node placement technique (node density variation) and routing (ETX and RE).
- Network Scenario 6 (NS6) - Proposed Network architecture that integrates node placement technique (variable battery level) and routing (ETT and RE).

- Network Scenario 7 (NS7) - Proposed Network architecture that integrates node placement technique (variable transmission range) and routing (ETT and RE).

3.5.2 Simulation Parameters

Table 3.2: Simulation Setup

Routing Protocol	AODV, AODV (RE +ETT), AODV (RE +ETX)
MAC layer/ Physical Layer	IEEE 802.15.4
Channel Type	Wireless
Traffic Type	Constant Bit Rate
Number of nodes	200
Packet error rate of 1 meter distance	0.8 %
Radio Propagation Model	Two Ray Ground
Antenna Model	Omni Directional
Total Number of Nodes	200
Packet	IPv6

3.5.3 Performance Parameters

Performance of proposed network architecture is compared with the performance of standard model (standard AODV and IEEE 802.15.4) and EQSR Ben-Othman, J. et al. (2010) protocol since EQSR is one of the standards cross layer protocol that is introduced to improve the performance in IoT Network.

3.5.3.1 Network Lifetime

The main goal of our research work is to enhance the lifetime of low power IoT networks. The lifetime of the nodes estimate the energy efficiency of the network. The lifetime of the network is estimated by the first node drain out, since every node in the network drains out its power in a short span of time. Therefore, network lifetime is estimated by the first node drain out, as well as it is estimated based on the number of nodes survived for entire simulation period.

From Figure 3.9 and Table 3.3, it is observed that in standard model (IEEE 802.15.4 AODV), first node drains out its power in 303 seconds. In EQSR first node

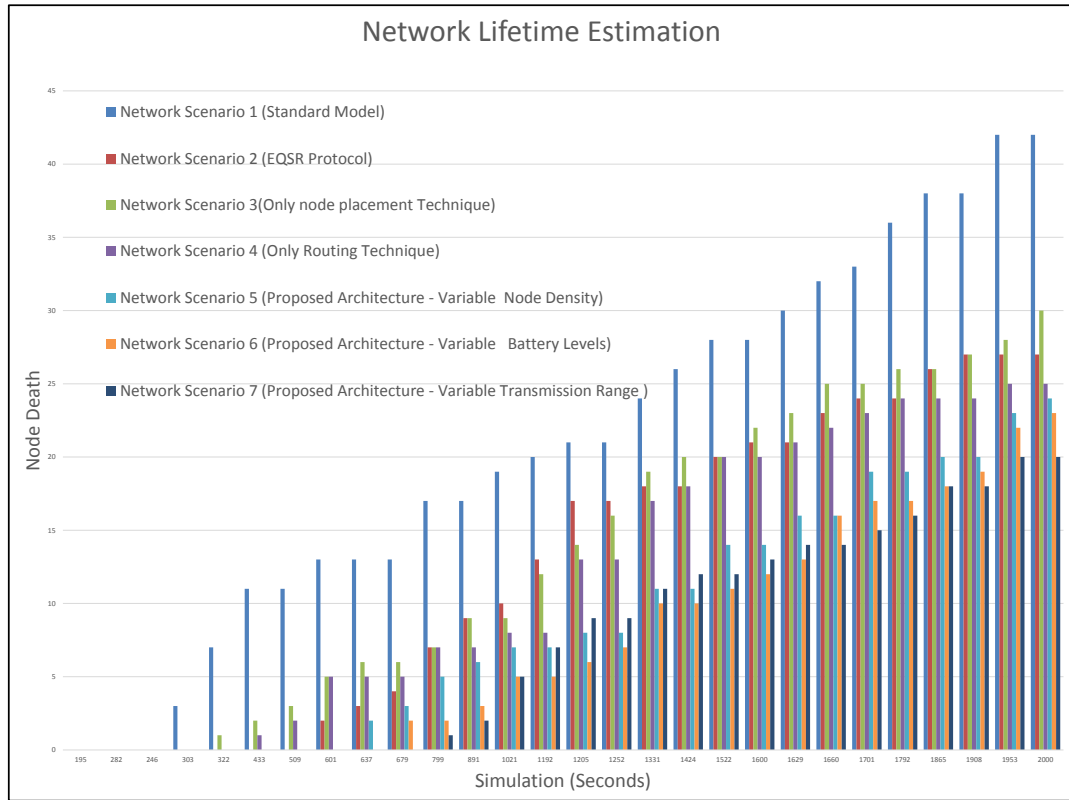

Figure 3.9: Network lifetime estimation of proposed network architecture

drains out its power at 601 seconds and in proposed network architecture (node density variation) first node drains out its power in 637 seconds, in proposed network architecture (variable battery level) first node drains out its power in at 679 seconds, in proposed network architecture (variable transmission range) first node drains out its power in 799 seconds. In standard model, only 8 nodes survived for whole simulation period, where as in EQSR 23 nodes survived for whole simulation period and proposed network architecture 30 nodes survived for whole simulation period. From these results it is seen that, proposed network architectures outperforms standard protocol (IEEE 802.15.4 and AODV) and EQSR protocol in network lifetime.

3.5.3.2 Average Energy Consumption

Energy hole issue and frequent network re-initialization can be avoided by balancing the energy utilization. Balanced energy consumption is estimated by the average energy consumption of nodes in the network. From Figure 3.10, it is observed that

Table 3.3: Network lifetime estimation of proposed network architecture

Techniques	NS1	NS2	NS3	NS4	NS5	NS6	NS7
First node death	303 sec.	601 sec.	322 sec.	433 sec.	637 sec.	679 sec.	799 sec.
Node survived	8	23	20	25	26	27	30
Average Node death	21	13	14	12	10	8	7
500 (sec) node death	11	0	3	2	0	0	0
1000 (sec) node death	18	10	9	8	7	5	2
1500 (sec) node death	28	20	20	20	14	12	9
2000 (sec) node death	42	27	30	35	25	24	23

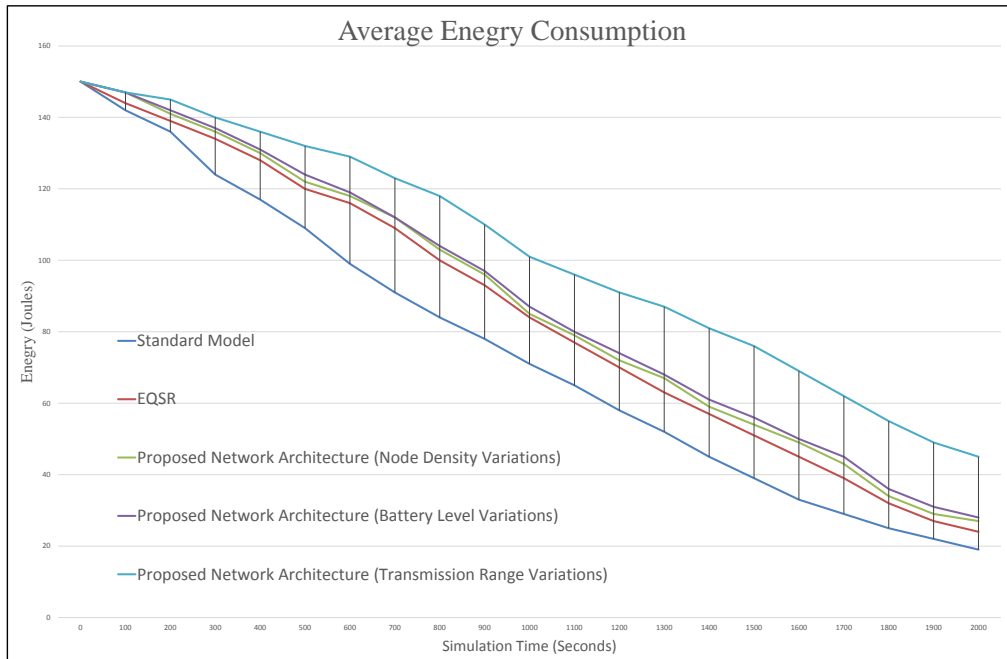

Figure 3.10: Average energy consumption analysis for proposed network architecture

proposed network architectures balance energy consumption in an efficient way. It outperforms standard model and EQSR protocol. Balancing energy consumption highly improves the lifetime of the network. Hence, it is concluded that proposed network architecture is efficient in energy utilization.

3.5.3.3 Throughput

:

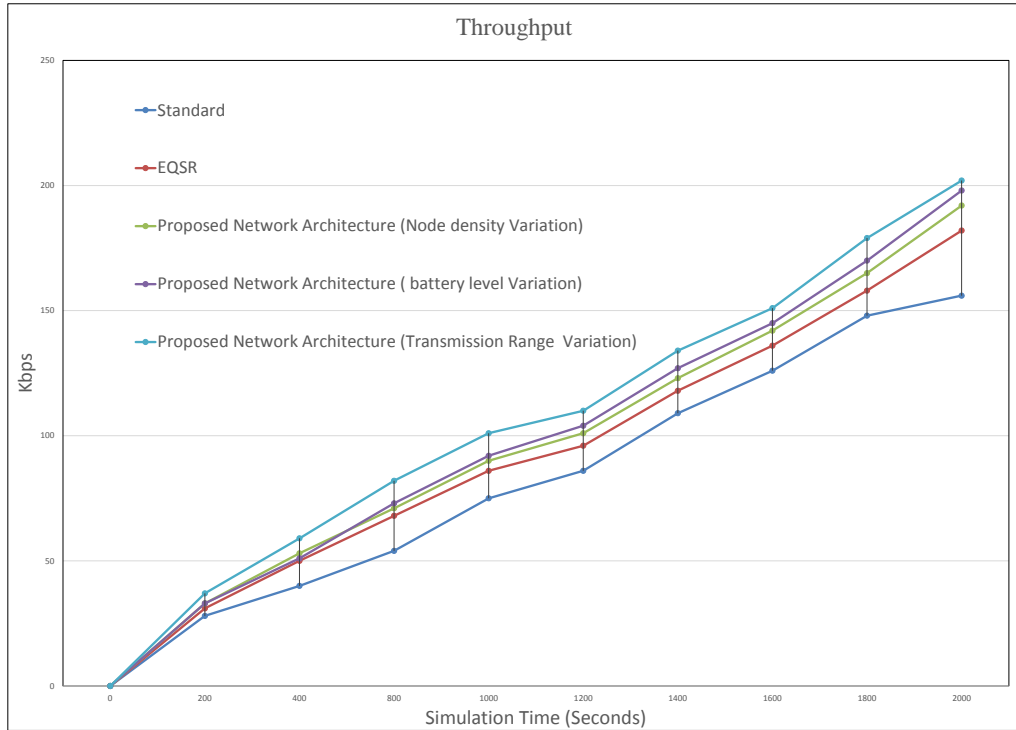

Figure 3.11: Throughput analysis for proposed network architecture

The number of packets successfully transmitted during data transmission phase is referred as throughput. Throughput is the fundamental parameter to estimate the network reliability. Thus, throughput is analyzed to estimate the reliability of the proposed network architectures. Figure 3.11, describes the throughput comparisons of the proposed network architectures and the standard model. In the above graph, it is noticed that the proposed network architectures achieve better throughput than standard model and EQSR protocol. From the simulation results, it is observed that the proposed network architectures perform better in energy efficiency and also maintains the reliability of the low power IoT Network.

3.6 SUMMARY

- In this Chapter, we have introduced routing technique and node placement technique integrated network architecture. Data traffic regulation, balanced energy utilization and reliable data transmission are the effective solutions to enhance network lifetime.

- In proposed network architecture data traffic is regulated by node placement technique and balanced energy utilization and reliable data transmission is assured by routing technique. Thus, to utilize the features of these two technique together, we proposed network architecture that integrates routing and node placement technique.
- However, proposed network architectures improve energy efficiency of the network, it creates additional implementation time. Node placement is done in network setup phase and routing is performed in routing phase, which creates additional network implementation time as well as network re-initialization time. Thus, to avoid this issue, we come up with cross layer model, which is elaborated in Chapter 4.

Chapter 4

NODE DEGREE AND TRAFFIC LOAD BASED CROSS LAYER MODEL

Outline of the Chapter

- Section 4.1 describes the need for cross layer model in IoT Networks.
- Section 4.2 introduces the features of cross layer model and various types of cross layer models.
- Overall description of proposed ND and TL based cross layer model is presented in section 4.3
- Simulation results of proposed ND and TL based cross layer model are validated and analyzed in section 4.4
- Section 4.5 summarizes the overall features of ND and TL based cross layer model.

4.1 INTRODUCTION

Non-uniform energy drainage is one of the crucial issues that occur in energy constrained networks. Nonuniform energy drainage refers to the uneven energy utilization of the nodes in the network. Therefore, to utilize the energy related features

in various layers of the protocol stack, we initially proposed a network architecture that integrates routing technique and node placement technique, which is presented in Chapter 3. Although routing and node placement integrated network architecture enhance the lifetime of networks, they are implemented in two different phase of network design. Node placement is implemented in the network setup phase and routing is implemented in the routing phase, which increases network implementation time as well as network re-initialization time. Since, In node placement technique, nodes should be deployed in planned way (dividing the whole network into various concentric rings and deploying the nodes with respective to the data traffic), this process may consume huge time. To avoid this issue, we come up with a cross layer model that overcomes network implementation issue and prolongs the network lifetime. The proposed cross layer model unifies the features of routing and MAC based power control techniques in the same phase of network.

Three different phases involved in proposed cross layer design.

- **Network setup phase (Random Node Placement)** – Deploying nodes randomly in the network environment.
- **Routing Phase (Routing Technique)** – control packet transmission and reception and path computation by nodes.
- **Data Transmission Phase** – Data transmission from source to destination.

4.2 CROSS LAYER MODEL FOR LOW POWER IOT NETWORKS

Networking technologies are being developed to meet the requirements of modern communication systems. Well established protocol architecture pursue standard layering procedures to obtain effective network setup. However, in standard protocol architectures flexible information flow between the layers are restricted, which limits the performance of IoT Networks (energy constrained networks). Therefore, cross layer design is one of the efficient innovations, that is developed to avoid the limitations of regular network architectures. The main idea behind the development of cross layer design is to maintain the operation of every layer, while at the same time, enabling the co-ordination between the different layers (allowing information flow between the

layer). Information exchange among the cross layer models varies from each other. Integration of layers can be implemented in different ways (Srivastava, V. et al. (2005)), such as,

Upward flow : In the protocol stack, if the higher layer needs to utilize the information of lower layers, it is required to initiate an effective interface between the lower layers and higher layers, which is referred to as upward flow cross layer design. In upward information flow, lower layers apprise the network condition to higher layers to avoid deterioration in the network performance (Xylomenos, G. et al. (2001)).

Downward flow : In some applications, lower layers require the application information (on demand dense information) from higher layers. In such case, lower layers can be integrated with higher layers to improve the network performance. The interfacing mechanism for downward flow cross layer design is similar to the upward flow cross layer design (Larzon, L. A. et al. (2002)).

Back and forth flow : Back and forth flow refers to the information flow that occurs from lower layers to higher layers and vice versa. This interface enables the collaboration between different layers in network (ElBatt, T. et al. (2004)).

Merging two adjacent layers : Interfacing two or more adjacent layers together without creating a new interface in the protocol stack is referred to as merging two adjacent layers (Dimic, G. et al. (2004)).

Coupling various layers without creating extra interfaces : It is similar to merging two adjacent layers. In this type of interfacing, two or more layers can be coupled at design time, without creating any additional interfaces (Tong, L. et al. (2004)).

Vertical calibration across layers : Adjusting the design parameters to span across the layers is referred to as vertical calibration. Instead of setting the parameters individually, merging and tuning the parameters based on network requirements, improves the network performance (Liu, Q. et al. (2004)).

Creating additional layers in the cross layer design increases the network complexity. since excess control packet transfer can be avoided when there is no additional layer interfacing.

4.3 OVERVIEW OF ND and TL BASED CROSS LAYER MODEL

The physical layer, data link layer, network layer and TCP/IP layer are the layers that play a significant role in the optimization of the communication unit of the network. Based on this observation, the physical layer, MAC (data link) layer and network layer are interfaced in the proposed model, to utilize communication unit in optimized way. In the proposed cross layer mode, energy associated routing metrics such as traffic load (TL) and node degree (ND) opt for path computation. At the completion of the flooding process (route discovery process) every nodes obtain their ND and TL information, which is named as weight factor value. MAC based power control techniques adopt this weight factor value and adjust the transmission range of nodes, which will be the suitable transmission range to achieve energy efficiency. In flat based network scenario, nodes farther from the base station hold less data traffic even though they have higher node degree, whereas nodes nearer to the base station holds huge data traffic, though they have less node degree. From this observation, it is understood that both node degree information and traffic load information are essential for avoiding energy hole issue. Thus, we proposed ND and TL based cross layer model that achieves the optimal transmission range. Protocols such as IEEE 802.15.4 PHY, IEEE 802.15.4 MAC, AODV, IPv6, UDP are employed in the proposed cross layer model. The following subsections describe the features of proposed network model in detail. Figure 4.1, describes the blue print of proposed cross layer model.

4.3.1 Network Model

- Some of the IoT applications follow flat based network scenario. Thus we adopt the flat based network scenario in our network model. In the simulation scenario, n number of nodes are placed in random manner in a network with dimensions of $N \times N$ (Penrose, M. et al. (2003)).
- To ensure network connectivity, we adopt $G = (V,E)$ graph model, where V indicates the vertices (sensor nodes) and E indicates the edges (wireless links)
- Radio links used in our network scenario are considered as bi-directional. Battery limited nodes are used in our simulation scenario, since IoT applications are

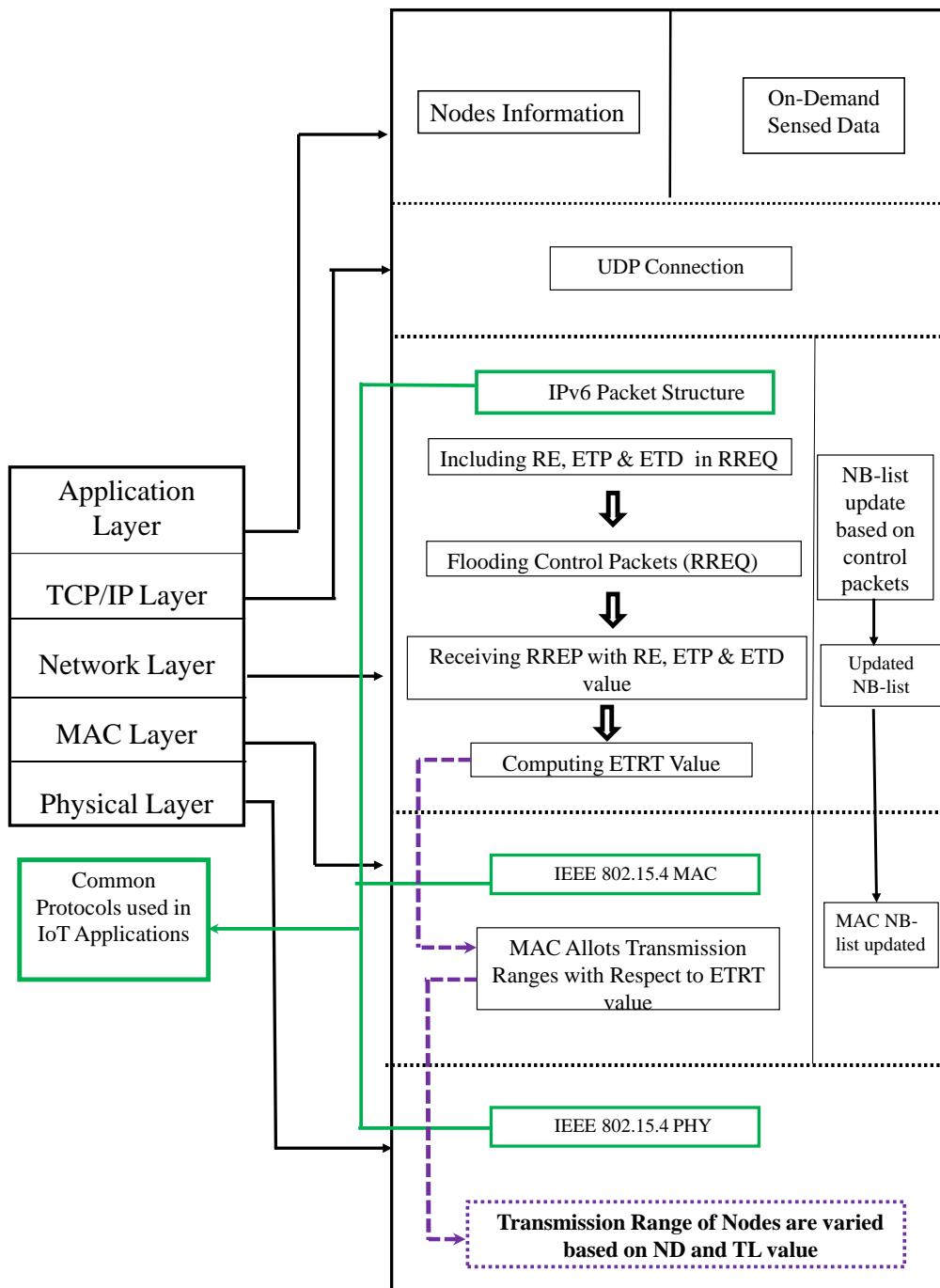

Figure 4.1: Blue Print of ND and TL based cross layer model

operated by battery sourced devices, where the base station (sink node) is not limited by energy (Dimic, G. et al. (2004)).

- It is assumed that nodes are aware of its node degree information (ND) and traffic load (TL) information (Gupta, S. K. et al. (2012),Farooq, H. et al. (2013)).
- In our simulation scenario, every node is assumed to be a source node, because each node in the sensing environment perform sensing and transmits the sensed data to the base station within a limited span of time (Srivastava, V. et al. (2005)).
- To obtain better connectivity and reliable communication, the communication range of nodes is kept twice the value of sensing range. In the proposed model, it is assumed that every node is capable of varying their transmission range (Li, J. et al. (2009)).

4.3.2 Power Consumption Model

In the simulation scenario, IEEE 802.15.4 PHY and MAC radio protocols are used. IEEE 802.15.4 enabled transceiver circuit operates in three different modes.

- Transmit state (Ptx): Packet transmission mode.
- Receive state (Prx): Packet reception mode.
- Idle state (Pidle): Mode that keeps the transceiver circuit idle.

$$P_{avg} = \frac{P_{idle} \times T_{idle} + P_{tx} \times T_{tx} + P_{rx} \times T_{rx}}{T_{ib}} \quad (4.1)$$

Average power consumption model is adopted from (Xiao, Z. et al. (2010)) In the above equation, the time required to transmit the packet is Ttx, time need to receive the packet is Trx, Time spend in the idle state is Tidle. Tib Inter-beacon period is the time lag between each of the beacons sent by the router or access points. Inter-beacon period is defined as Tib.

$$T_{ib} = T_{ibmin} \times 2BO \quad (4.2)$$

BO is the beacon order, which is scaled from 0-15 and Tibmin refers to the minimum super frame duration.

4.3.3 Network Parameters

To elaborate on the features of the proposed cross layer model, initially we brief the network parameters that are considered for WF computation.

The parameters that help for WF computation is described in following.

- WF: Weight factor value.
- ND: Node degree information.
- TL: Traffic load information.
- α : weight assigned for ND.
- β : weight assigned for TL.

4.3.4 Routing Mechanism

In most of the cross layer proposals, routing is described as an apt technique to obtain the topology information. Every node obtains the network topology information by control packet transmission and reception. Other layers in the protocol stack utilize the topology information provided by the routing technique and optimizes the network performance. Thus, routing technique has a significant role in any kind of cross layer model. AODV (Adhoc On-demand Distance Vector) routing protocol is used for path discovery. To improve network lifetime, routing metrics such as node degree (ND) and traffic load (TL) are included in AODV routing protocol. The intuition behind the selection of AODV protocol is it utilizes bandwidth in an effective way and it exhibits self healing capabilities in the event of node failures.

Node degree: Node Degree : The Number of neighbor nodes that exist within the transmission range of a particular node is referred to as Node degree (ND) (Gupta, S. K. et al. (2012)).

Traffic Load : The traffic load for a particular node can be measured by calculating the interval between two received data packets. Measuring the time interval between two received data packets is referred as an interval. Old interval refers the time interval between old received data packets and new interval refers the time interval between currently received data packets. (Farooq, H. et al. (2013)). The normalized factor (β) is scaled from 0-1, with 1 denoting minimum traffic load. Traffic load for a node can be defined as,

$$TF = (((1 - \beta) \times oldinterval) + (\beta \times newinterval)). \quad (4.3)$$

In the proposed cross layer model we include a routing metric called traffic load to specify the traffic intensity of the node in advance. It keeps the packet drop rate and multi-retransmission in check, which improves the energy efficiency and reliability of the network.

4.3.5 Weight Factor Computation

At the end of the routing phase (control packets flooding), information about the node degree (ND) and traffic load (TL) information is attained by each node. Every node calculates the weight factor by using the routing information (ND and TL information). In our model, the weight factor is calculated by using the weighted sum approach (ND and TL information is combined by weighted sum approach) The weight factor of the proposed model is defined as,

$$WF = \alpha \left(\frac{ND}{MaximumND} \right) + \beta \left(\frac{TL}{MaximumTL} \right) \quad (4.4)$$

ND and TL information can be included in AODV routing protocol, by adding them into the control packets of AODV routing protocol. The value of β and α are scaled from 0 to 1. Figure 4.2, describes the control packet structure of the proposed model. After obtaining routing information (ND and TL), every node adjusts and obtain optimum transmission range with the help of MAC based power control technique (Section 3.4.1). In the proposed model, IEEE 802.15.4 MAC protocol is used to govern the radio operations. In all types of wireless networks, RX and CS thresholds are decided by transmitting power level of nodes Jung, E.-S. et al. (2002). Transmit power level of every node is assigned based on WF value.

The following steps elaborate the operational flow of proposed cross layer model. In this model every node is considered as source node as well as the destination node. And let us consider the operation of node(x) that can vary its transmission range.

- *Step 1: Start*
- *Step 2: Initially all nodes floods route request packet in the network.*

Type	Flags	Reserved	Hop count
RREQ (broadcast) ID			
Destination IP Address			
Destination Sequence Number			
Original IP Address			
Original Sequence number			
Node Degree and Traffic Load Information			

Figure 4.2: Control packet structure of ND and TL based cross layer model

- *Step 3: When the route request packets (RREQ) reaches the node (x), it computes the WF value (Node degree and traffic load value).*
- *Step 4: Node (x) compares WF value with transmission range (CS and RX threshold values of IEEE 802.15.4 MAC protocol).*
- *CS and RX threshold values of IEEE 802.15.4 protocol*
set dist(5 meter) 7.69113e-06 Transmission range 1
set dist(10 meter) 1.92278e-06 Transmission range 2
set dist(15 meter) 8.54570e-07 Transmission range 3
set dist(20 meter) 4.80696e-07 Transmission range 4
set dist(25 meter) 3.07645e-07 Transmission range 5
set dist(30 meter) 2.13643e-07 Transmission range 6
set dist(35 meter) 1.56962e-07 Transmission range 7
set dist(40 meter) 1.20174e-07 Transmission range 8

- *Step 5: Finally, Node (x) utilizes MAC based power control technique and adjusts the transmission range, based on obtained WF value.*
- *Step 6: Stop.*

4.3.6 Network Specification to Adopt IoT Scenario in the Simulation Scenario

IPv6 brings the concept of large address spacing. IEEE 802.15.4 PHY/MAC (Marandin, D. et al. (2009)) is the well known radio protocol that is practiced in some of the IoT applications, since IEEE 802.15.4 PHY, IEEE 802.15.4 MAC and Internet Protocol version 6 (IPv6) (Deering, S. E. et al. (1998)) are used to design the proposed cross layer model. Nodes used in the network scenario are battery limited, since most of the IoT applications are constructed with battery limited nodes. Thus, all these basic features are adopted in our simulation scenario, to bring the IoT scenario in proposed cross layer model.

4.3.7 Simulation Results and Analysis

4.3.7.1 Specifications of the Simulation Scenario

NS-2.34 (Network Simulator version 2.34) is used to evaluate the performance of the proposed cross layer model. The NS -2 simulators is run on a machine with ubuntu 14.04 as the host.

4.3.8 Performance Evaluation

Performance of the proposed cross layer model is estimated by the following parameters. Standard model (standard AODV and IEEE 802.15.4) and the EQSR (Ben-Othman, J. et al. (2010)) protocol is used to analyze the performance of the proposed cross layer model.

4.3.8.1 Network Lifetime:

Network lifetime is estimated based on the first node death since the lifetime of whole network depends on first node death. Once a node in the network drains out of its

Table 4.1: Simulation setup

Routing Protocol	AODV, AODV (ND and TL)
MAC layer/ Physical Layer	IEEE 802.15.4
Channel Type	Wireless
Radio Propagation Model	Two Ray Ground
Traffic Type	Constant Bit Rate
Antenna Model	Omni Directional
Initial Energy (Sensors)	200 joules
Transmission ranges	8 RX and CS Threshold ranges
Total Number of Nodes	200
Packet	IPv6
Packet error rate of 1 meter distance	0.8 %

power, within a short span of time, the remaining nodes will follow suit. Table 4.1, describes the specifications of simulation parameters.

Table 4.2: Network lifetime estimation of ND and TL based cross layer model

Protocols	Standard	EQSR	Proposed model
First node death	510 seconds	752 seconds	891 seconds
Average node death	77	63	53
Nodes survived	11	24	31
Node death for 1000 sec.	48	32	15
Node death for 1500 sec.	125	95	89
Node death for 2000 sec.	189	176	169

Figure 4.3. and Table 4.2, describes the network lifetime estimation of the proposed cross layer model. In standard model (IEEE 802.15.4 and AODV) first node drains out its power at 510 seconds, in EQSR first node drains out its power at 752 seconds and in proposed cross layer model first node drains out its power at 891 seconds. In standard model, 11 nodes survived for whole simulation period, where in EQSR 24 nodes survived for whole simulation period and cross layer model 31 nodes survived for whole simulation period. And from table 4.2, it is observed that the maximum number of nodes (80 nodes) lose their energy from 1500 seconds to 2000 seconds, which says proposed cross layer model performs efficient energy utilization and maximizes the lifetime of nodes. Hence, the proposed cross layer model outperforms standard protocol and EQSR in network maximization.

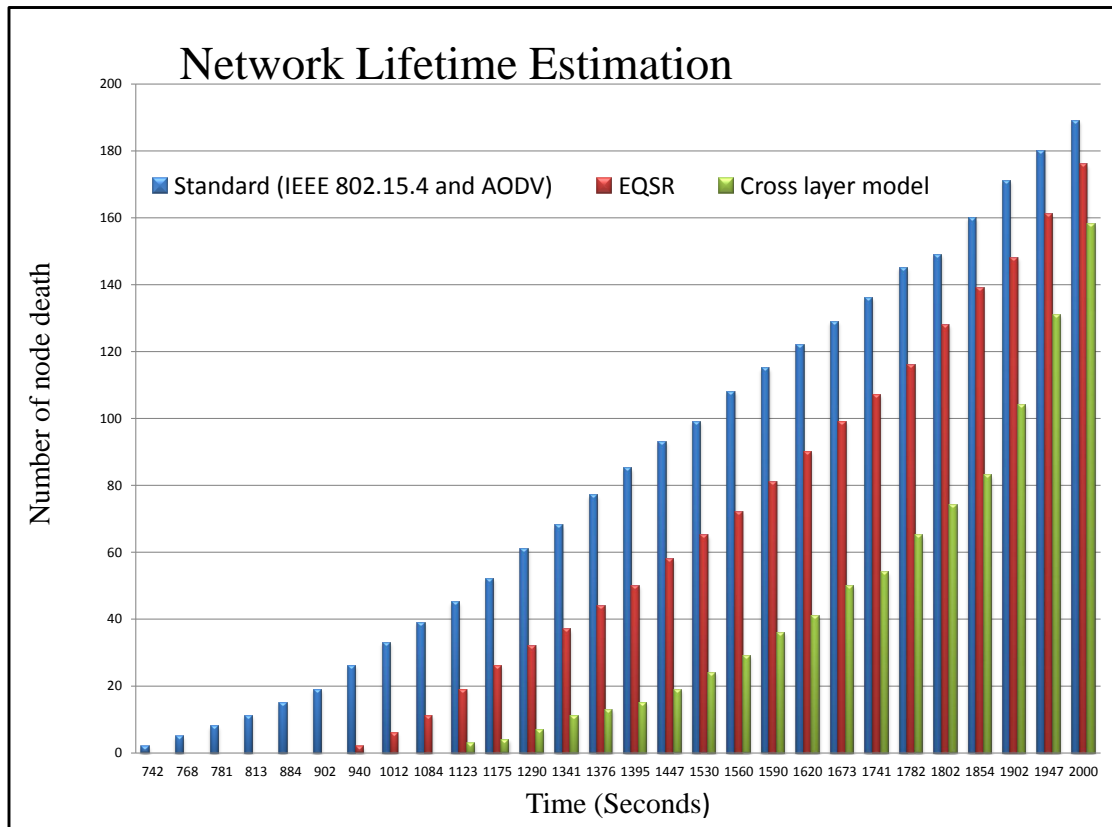

Figure 4.3: Network lifetime estimation for ND and TL based cross layer model

4.3.8.2 Average Energy Consumption

The energy consumption of the network is measured based on the average energy consumption of nodes. Figure 4.4. describes the estimation of average energy consumption of nodes in proposed cross layer design and in standard protocol designs. From Figure 4.4, it is observed that the proposed cross layer model balances energy in an efficient way. Balancing energy consumption highly improves the lifetime of the network. Hence, it is concluded that proposed cross layer model is efficient in energy utilization.

4.3.8.3 Throughput

The number of packets successfully transmitted during data transmission phase is referred as to throughput. Throughput is a fundamental parameter to evaluate the network reliability. Thus, throughput is calculated to estimate the reliability of the

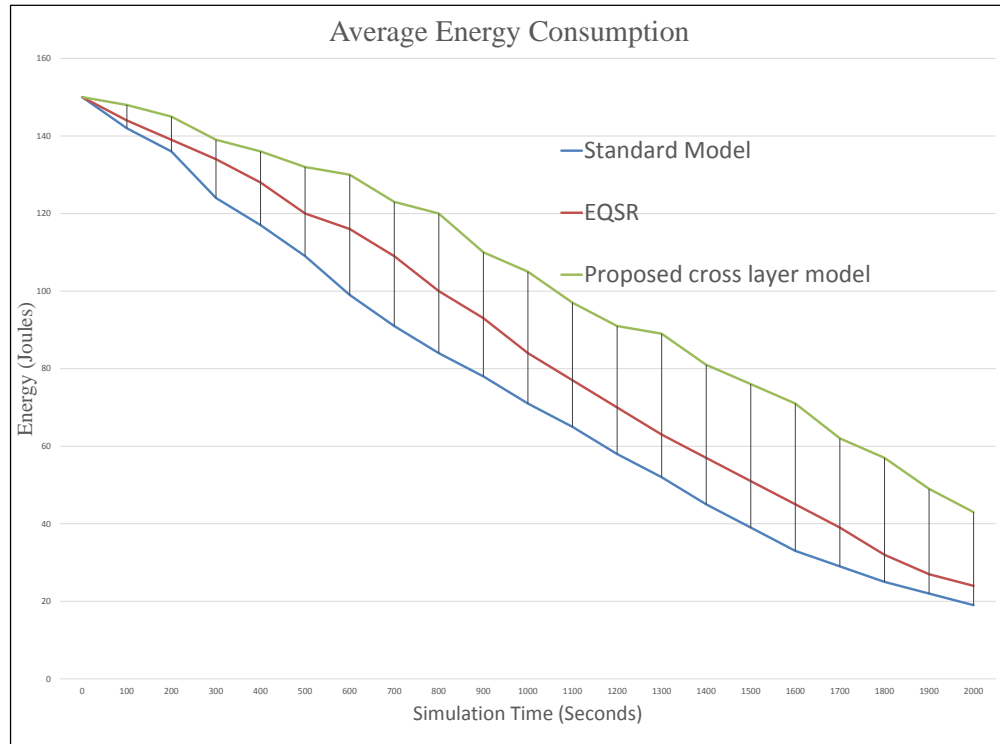

Figure 4.4: Average energy consumption analysis for ND and TL based cross layer model

proposed network architecture.

Figure 4.5, describes the throughput comparisons of the proposed cross layer model and the standard model. In the above graph it is noticed that the proposed cross layer model achieves better throughput than standard model. From the simulation results it is observed that the proposed cross layer model performs better in energy efficiency and also maintains the reliability of the network.

4.4 SUMMARY

- In any kind of network research, physical layer, data link layer, network layer are mainly involved in energy optimization. From this observation, we integrated these three layers together in proposed cross layer model.
- In proposed cross layer design, energy related routing metrics such as traffic load (TL) and node degree (ND) are included in path computation. Later MAC

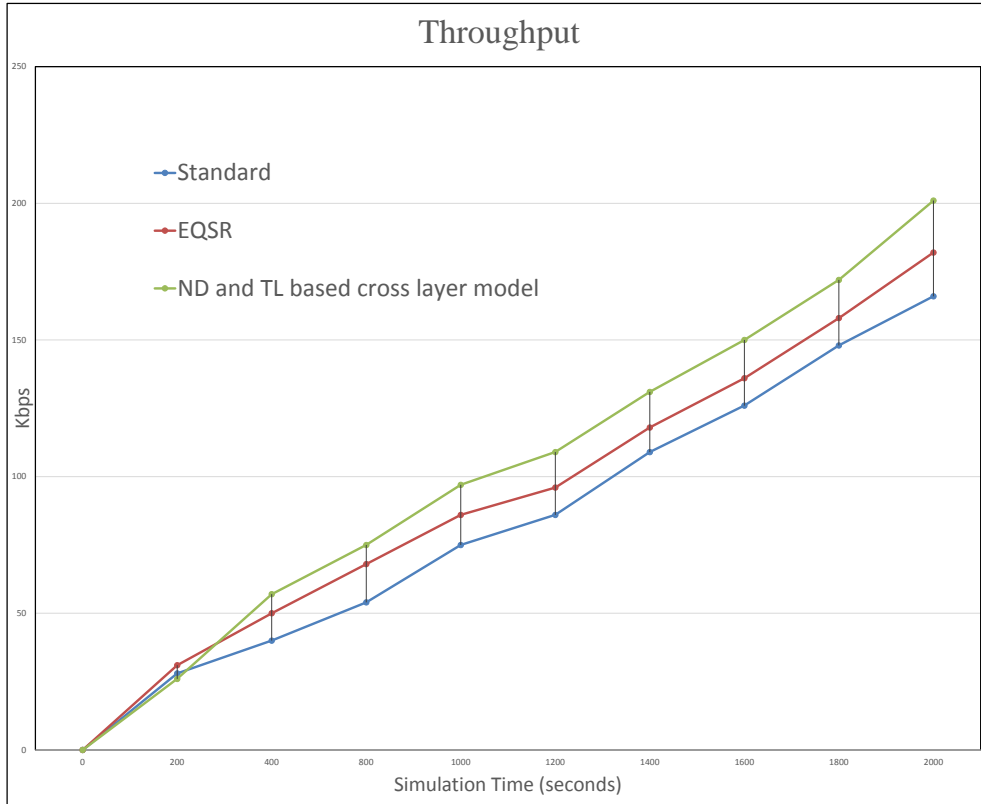

Figure 4.5: Throughput analysis for ND and TL based cross layer model

based power control technique utilizes traffic load (TL) and node degree (ND) value and adjusts the transmission range of nodes, which will be the suitable transmission to enhance the network lifetime.

- However, the proposed cross layer model concentrates only on energy related parameters and network lifetime. Reliability and QoS related information also need to be considered for enhancing the network performance. In IoT Network, the overall network performance depends on various factors such as lifetime of battery sourced devices, reliable data transfer and QoS assured communication. Thus, in Chapter 5 the cross layer model called as ETRT (Expected Transmission Range Threshold) - cross layer model, that considers all energy, reliability and QoS related information is proposed.

Chapter 5

ETRT BASED CROSS LAYER MODEL

Outline of the Chapter

- Section 5.1 elaborates the scope of ETRT-cross layer design.
- Section 5.2 describes the clear overview of the ETRT-cross layer design
- Performance of proposed ETRT based cross layer model has been validated by simulation results and shown in Section 5.3.
- Finally, Section 5.4 summarizes this Chapter.

5.1 INTRODUCTION

The prime aspiration of IoT technology is to upgrade the resource utilization in an efficient manner. Network lifetime is one of the main objectives in low power IoT networks. In the previous Chapter, it is shown that ND and TL based cross layer design prolongs the lifetime of low power IoT networks. ND and TL based cross layer design obtain optimum transmission range, by utilizing traffic information (node degree and traffic load) of nodes. Although it improves the network lifetime, reliability and QoS related information also need to be considered for improving the overall network performance. Since the overall performance of IoT Network relies on the network lifetime, reliable data transfer and QoS assured communication. Many cross layer models (Al-Jemeli, M. et al. (2015), He, S. et al. (2012) , Madan, R. et al. (2006), Wang, J.

et al. (2010), Park, P. et al. (2011), Vuran, M. C. et al. (2010)) concentrate on a single aspect, either energy efficiency, reliability and QoS. However, cross layer model that concentrates on overall network performance is more essential for low power IoT Networks. Thus, in this Chapter new idea called ETRT (Expected Transmission Range Threshold), which considers energy, reliability and QoS related information is introduced. Energy utilization can be balanced by keeping track of the energy level of nodes. Reliable data transfer can be accomplished by transmitting data across the lossless links (stable links) and QoS can be achieved by reducing the transmission delay. Based on these observations the ETRT based cross layer model is designed. In the proposed ETRT based cross layer model, routing metrics such as residual energy (monitors energy level of nodes), expected throughput (stable links that gives better throughput) and expected transmission delay (predicts delay information of nodes) are considered in routing mechanism to estimate the capability of node and assigning suitable transmission range for every node based on its capability.

Three different phases involved in proposed cross layer design.

- **Network setup phase (Random Node Placement)** – Deploying nodes randomly in the network environment.
- **Routing Phase (Routing Technique)** – Control packet transmission and reception and path computation by nodes.
- **Data Transmission Phase** – Data transmission from source to destination.

5.2 OVERVIEW OF ETRT BASED CROSS LAYER MODEL

The Overall features of the ETRT based cross layer model are described in this section. The main goal of the proposed model is to increase the lifetime nodes with reliable communication. Network Layer, data link layer and physical layer are unified in the proposed ETRT (Expected Transmission Range Threshold) based cross layer model. In the proposed model, routing metrics such as residual energy (RE), expected throughput (ETP) and expected transmission delay (ETD) is added in the control packets of AODV routing protocol. In flooding process (transmission and reception of control packets) every node receives the RE, ETP and ETD values and they

calculate ETRT value. MAC based power control technique assigns the transmission range of nodes based on the ETRT value, which will be the efficient transmission range for every node in the network. Figure 5.1 describes the blue print of ETRT based cross layer model.

5.2.1 Network Model

- Flat based network scenario is prevalent in the network scenario for low power IoT applications. Therefore, the flat based network model is assumed for proposed cross layer model. In the proposed model nodes are deployed in random manner (Penrose, M. et al. (2003)).
- Network connectivity is adopted from the graph model $G = (V, E)$, where, V stands for vertices (nodes) and E stands for edges (radio links), which associate vertices (Wang, X. et al. (2003)).
- Bi-directional links are used to connect the nodes. Energy restricted (battery operated) nodes are deployed in our network scenario since some of the IoT applications practice battery operated nodes and low power radio links for collecting physical information (Dimic, G. et al. (2004)).
- In the simulation scenario, internet enabled devices (Deering, S. E. et al. (1998)) are aware of routing metrics such as expected throughput (ETP), residual energy (RE) and expected transmission delay (ETD).
- In the proposed cross layer model, AODV is used for the route discovery process (Perkins, C. et al. (2003)), IEEE 802.15.4 MAC and IEEE 802.15.4 (Callaway, E. et al. (2002)) are utilized for the physical and MAC layer operation.
- Each node in the network is assumed to be a source node since every node in the network sense the physical information and transmit it to sink in particular time cycle allotted to them (Azzedine Boukerche (2008)).
- The Communication range of the node is kept twice that of the sensing range, to maintain network connectivity. In this model, nodes can vary its transmission range based on its incoming control packet information (Li, J. et al. (2009)).

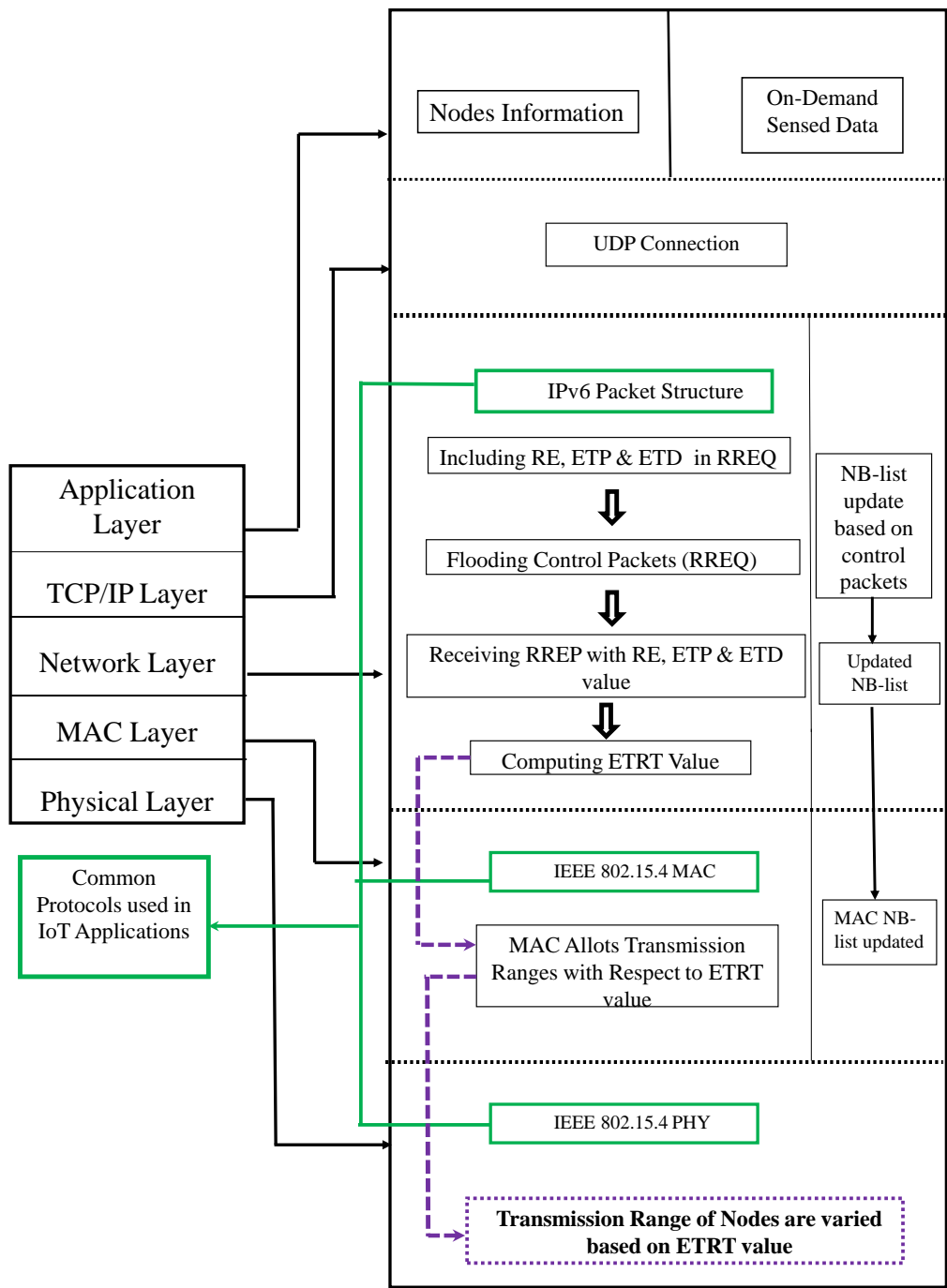

Figure 5.1: Blue Print of ETRT based cross layer model

- Power consumption model for ETRT based cross layer model is adopted from 4.3.2.

5.2.2 Network Parameters

To elaborate on the features of the proposed cross layer model, initially we brief on the network parameters that are required for ETRT computation.

The parameters that contribute in ETRT computation is described in following.

1. RE: Residual energy (nodes available energy level).
2. E_r : Remaining energy of the node
3. E_{max} : Maximum energy of the node
4. ETP: Expected Throughput.
5. ETX: Expected Transmission Count.
6. D_f : Forward Packet Deliver ratio
7. D_r : Reverse Packet Delivery ratio.
8. b_i : Link Bandwidth.
9. ETD: Expected Transmission Delay.
10. $ETDec(t-1)$ denotes the past ETD.
11. α : weight assigned for RE.
12. β : weight assigned for ETP.
13. γ :weight assigned for ETD.
14. ETRT: Expected Transmission range threshold

5.2.3 Routing Mechanism for ETRT based Cross Layer Model

Routing refers to the method employed to access the network topology information. In various cross layer proposals, it is described that routing shares the topology information among the other layers and effectively resolves network bottlenecks. In ETRT based cross layer model, AODV (Adhoc On-demand Distance Vector) is chosen for path computation. In most of the energy aware routing proposals, it is seen that incorporating suitable parameters can satisfy application specific network requirements. From this observation, routing metrics such as residual energy (RE), expected throughput (ETP) and expected transmission delay (ETD) are incorporated into the standard AODV routing protocol. Using ETP, RE and ETD information, the ETRT value is calculated. The descriptions of residual energy, expected throughput and expected transmission delay are as follows.

Residual Energy : Non uniform energy wastage can be prevented by tracking the existing energy level of nodes (RE). Monitoring the nodes energy level and finding the data transmission path with sufficient energy level balances the energy utilization. Residual energy can be calculated as,

$$RE = \frac{Er}{Emax} \quad (5.1)$$

Er denotes the remaining energy of the node and Emax denotes the maximum amount of energy available in the node.

Expected Throughput :

In the proposed routing mechanism, an efficient routing metric called Expected Throughput (ETP) (Mhatre, V. P. et al. (2007)) is included, which ensures the quality of radio links by utilizing bandwidth sharing mechanism. ETP can adopt IBSS (Independent Base Service Set) mode, which has several advantages when compared to ETX (Expected Transmission Count) and ETT (Expected Transmission Time). Therefore, ETP is used in proposed routing mechanism to achieve reliable data transfer in the network. ETP for a specific link is described as,

$$ETP = \frac{D_f \times D_r}{b_i} \quad (5.2)$$

It can be written as,

$$ETP = \frac{1}{ETX \times b_i} \quad (5.3)$$

D_f and D_r refer to the forward packet delivery ratio and reverse packet delivery ratio of a particular link. b_i is referred as expected bandwidth received by the particular link. Link Bandwidth (b_i) of the network is calculated as,

$$b_i = \frac{1}{\sum_{j \in S_i \cap P} \frac{1}{r_j}} \quad (5.4)$$

Let us assume a particular link I belongs to path P in the contention domain S_i . $S_i \cap P$ is the set of links on path P that contend with link i . r_j be the nominal bit rate of link i .

Expected Transmission Delay :

Delay is one of the prime issues that affect the QoS of the network. Therefore, to avoid network delay, a routing metric called Expected Transmission Delay (ETD) (Mena, J., et al. (2008)) is included in the proposed cross layer model. ETD estimates the time consumed for transmitting the packet from one node to another node (end to end delay). ETD (Mena, J., et al. (2008)) is computed by averaging the present hop delay and past ETD. ETD is expressed as,

$$ETDec(t) = \delta \times Dec + (\delta - 1) \times ETDec(1 - t) \quad (5.5)$$

ETDec (1-t) is defined as past ETD and present hop delay. By using sliding window past ETD is computed, δ is the scaling factor or weight factor.

5.2.4 Deriving ETRT based on Weighted Sum Approach

The Expected Transmission Range Threshold (ETRT) is the prime idea behind the design of the proposed cross layer model. In the proposed cross layer model, ETRT value refers to the nodes capability. Combination of parameters such as RE,ETP and ETD can improve the network performance, since they are good measure of the energy efficiency, reliability and QoS information of every node in the network. Every node relies on the ETRT value (nodes capability) to obtain their optimum transmission range. Routing technique and MAC based power control technique performs the computation and utilization of ETRT value (obtaining optimum transmission range of nodes). ETRT value is computed based on the weighted sum approach.

ETRT value derived from the route discovery process is defined as.

$$ETRT = \alpha \left(\frac{ND}{MaxRE} \right) + \beta \left(\frac{ETP}{MaxETP} \right) + \gamma \left(1 - \frac{ETD}{MaxETD} \right) \quad (5.6)$$

Type	Flags	Reserved	Hop count
RREQ (broadcast) ID			
Destination IP Address			
Destination Sequence Number			
Original IP Address			
Original Sequence number			
RE, ETP and ETD			

Figure 5.2: Control packet structure of ETRT based cross layer model

Equation (5.6) defines the ETRT value. ETRT information is computed by including ETP, RE and ETD information in the control packet (Route Request packet) of AODV protocol. In equation (5.6) the value of α , β and γ are scaled from 0 to 1, such that $(\alpha + \beta + \gamma) = 1$. Route reply packet format is described in Figure 5.2.

After obtaining routing information (ETP, ETD and RE), Nodes in the network computes ETRT value with the weighted sum approach and they adjust the transmission range with the help of MAC based power control technique.

In the proposed model, IEEE 802.15.4 MAC protocol is used to govern the radio operations. In all types of wireless networks, RX and CS thresholds are decided by transmitting power level of nodes Jung, E.-S. et al. (2002). Transmit power level of every node is assigned based on ETRT value. In proposed work, IEEE 802.15.4 uses 8 transmit power thresholds with respective to ETRT value, which is scaled from 0-7. Therefore with the aid of MAC based power control technique every node obtain

suitable transmit power threshold by utilizing ETRT value.

5.2.5 Estimation and Utilization of Nodes Capability Information

The following steps elaborate the operational flow of proposed cross layer model. In this model, every node is considered as source node as well as the destination node. And let us consider the operation of node(x) that can vary its transmission range.

- *Step 1: Start*
- *Step 2: Initially all nodes floods route request packet in the network.*
- *Step 3: When the route request packets (RREQ) reaches the node (x), then node (x) computes the ETRT value (RE, ETD and ETP).*
- *Step 4: Node (x) compares the ETRT value with transmission range (CS and RX threshold values of IEEE 802.15.4 protocol).*

CS and RX threshold values of IEEE 802.15.4 protocol

set dist(5m) 7.69113e-06 Transmission range 1

set dist(10m) 1.92278e-06 Transmission range 2

set dist(15m) 8.54570e-07 Transmission range 3

set dist(20m) 4.80696e-07 Transmission range 4

set dist(25m) 3.07645e-07 Transmission range 5

set dist(30m) 2.13643e-07 Transmission range 6

set dist(35m) 1.56962e-07 Transmission range 7

set dist(40m) 1.20174e-07 Transmission range 8

- *Finally, Step 5: Node (x) utilize MAC based power control technique and adjusts the transmission range, based on obtained ETRT value.*
- *Step 6: Stop.*

The network lifetime is highly influenced by the communication unit of the network. To optimize the communication unit, the transmission range of the nodes need

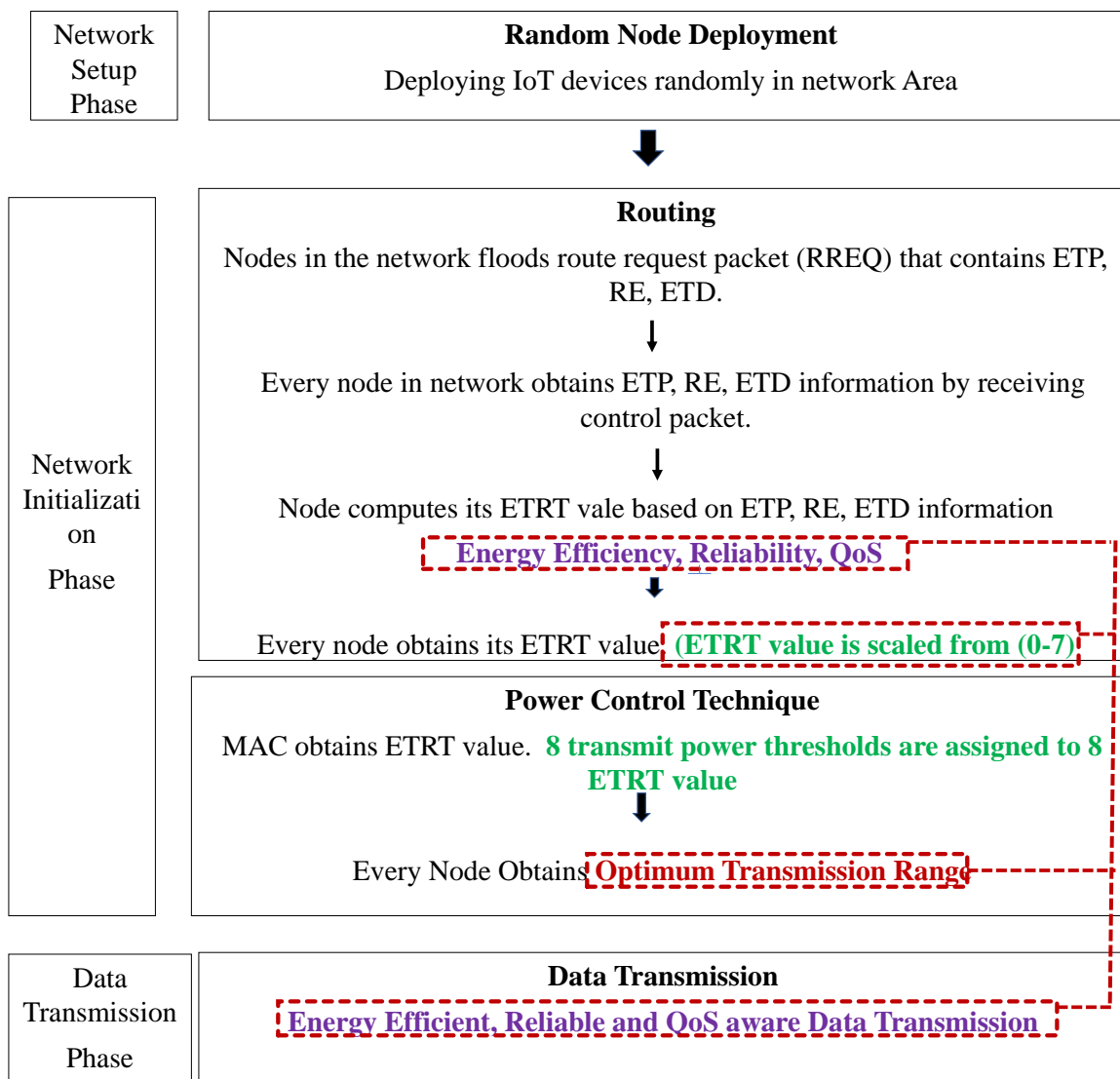

Figure 5.3: Operational flow of proposed cross layer model

to be regulated in an effective way. To assign suitable transmission range for every node, the capability of nodes need to be identified. Therefore, routing and power control techniques are integrated into the proposed model, in order to regulate the transmission range of nodes and obtain energy efficient transmission range for every node in the network. The regulated transmission range is considered to be the energy efficient, since the expected throughput, available energy and expected transmission delay are predicted for every node and based on this predictive value, the transmission range is varied for every node. Thus, proposed cross layer model regulates the

communication unit in an effective way. Figure 5.3 , describes the operational flow of proposed cross layer model.

5.2.6 Simulation Results and Analysis

5.2.6.1 Specifications of the Simulation Scenario

- NS-2.34 (Network Simulator version 2.34) is used for the simulations and NS-2 installation is done in the Linux Ubuntu. Patches are incorporated in NS 2to include IPv6 module and IEEE 802.15.4.
- The network area is chosen as 500 x 500 meters.
- Routing protocols such as AODV, EQSR (Ben-Othman, J. et al. (2010)) and Modified AODV (proposed cross layer model) are used in the simulation scenario to validate the network performance.
- IEEE 802.15.4 PHY/MAC is used to handle radio operations.
- Two Ray Ground radio propagation model is used in the simulation scenario.
- Every node initial energy is kept as 150 joules and 200 nodes are placed in our simulation scenario.
- 8 - different transmit power thresholds are used to vary the transmission range of nodes.
- Packet error rate of 1-0meter distance is 0.8 %

5.2.6.2 Performance Evaluation

We consider the following parameters to estimate the performance of ETRT based cross layer model.

5.2.7 Network Lifetime:

The prime objective of our research work is to obtain energy efficiency in low power IoT networks. Energy efficiency of the network is estimated by the lifetime of the nodes in the network. The Lifetime of the network can be determined based on the

first node death since when one node drain out its power completely the other nodes drain out its power within a short span of time the. Therefore, we estimate network lifetime by first node death as well as the number of nodes survived over the entire simulation period.

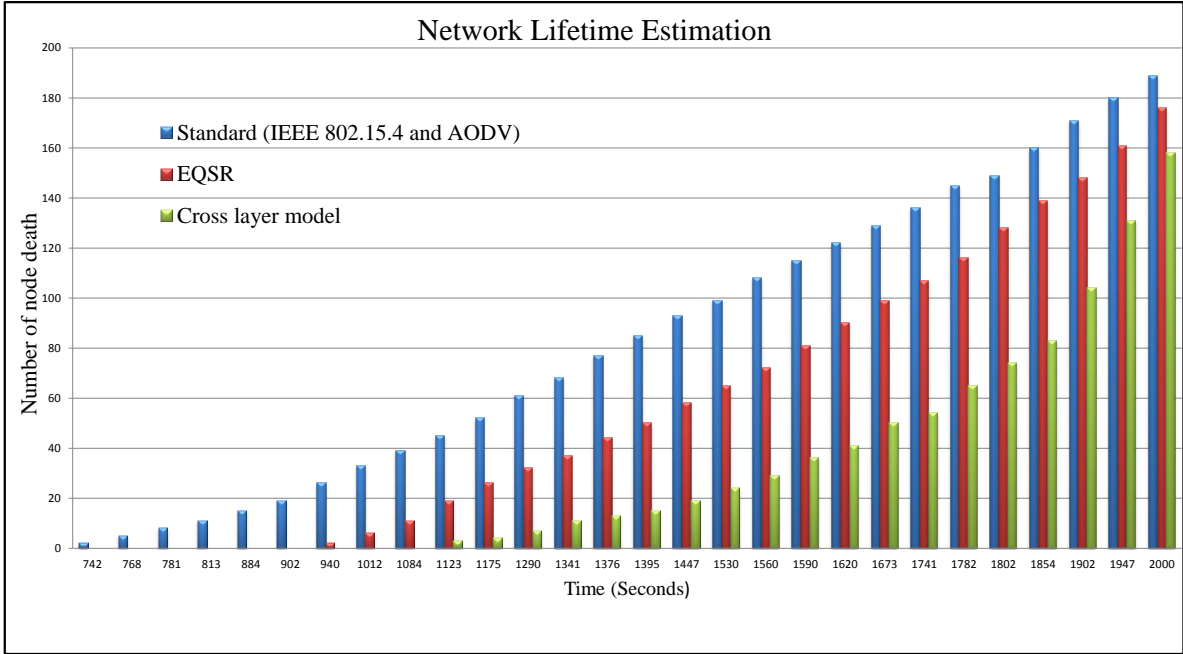

Figure 5.4: Network Lifetime Estimation of ETRT based cross layer model

Table 5.1: Network lifetime estimation of ETRT based cross layer model

protocols	Standard	EQSR	Proposed model
First node death	742 seconds	940 seconds	1123 seconds
Average node death	84	60	33
Nodes survived	11	24	42
Node death for 1000 sec.	33	6	0
Node death for 1500 sec.	99	64	25
Node death for 2000 sec.	189	176	158

Figure 5.4 , Figure 5.5 and Table 5.1, depicts the network lifetime comparisons of ETRT based cross layer model, the standard model and EQSR protocol. From Figure 5.4 , it is seen that first node drains out (first node death) its power in 742 seconds, whereas in EQSR protocol first node drain out its power in 940 seconds. In

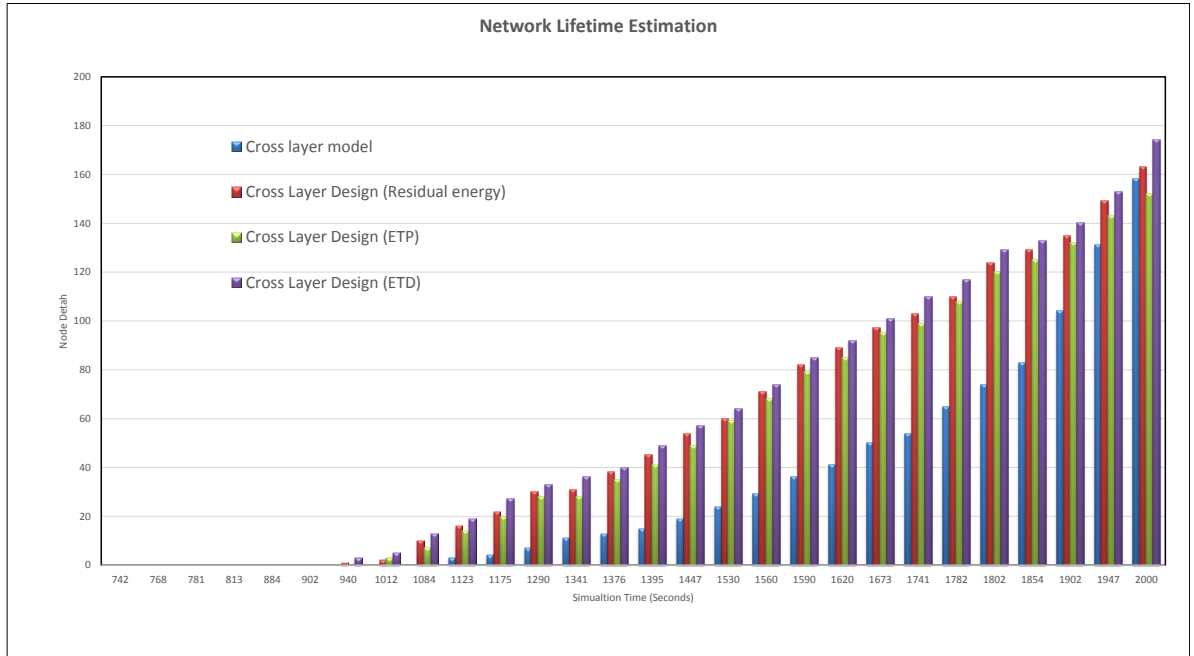

Figure 5.5: Network Lifetime Estimation of ETRT based cross layer model for three different parameters

ETRT based cross layer model, first node death ensue at 1123 seconds. Similar to observation of first node death, the number of nodes survived for whole simulation period need to be observed, to analyze the network lifetime of proposed cross layer model. In standard model, 11 nodes sustain its battery power for the entire simulation period, in EQSR network scenario 24 nodes sustain its battery power for throughout the entire simulation period. In ETRT based cross layer model, 42 nodes sustain its battery power for the entire simulation period. From the results of first node death and nodes survivability, it is understood that proposed ETRT based cross layer model achieves better network lifetime when compared to standard model and EQSR protocol. From Table 5.1 , it is noticed that approximately 125 nodes drain out its battery source in 1500 seconds to 2000 seconds, which describes ETRT - cross layer model does balanced energy consumption and enhances lifetime of nodes. Therefore, ETRT based cross layer model outperforms EQSR protocol and standard model.

In Figure 5.5 , network lifetime is estimated for four different network scenarios.

- Network Scenario 1 (NS1) Proposed cross layer model. (RE, ETP, ETD based routing)

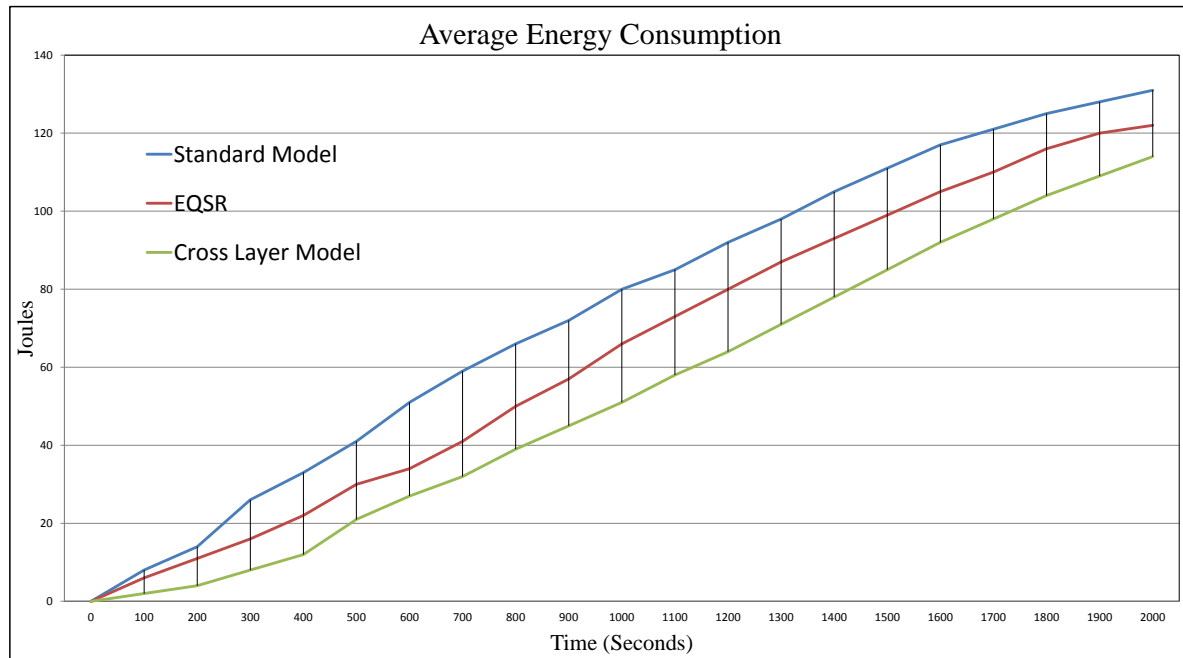

Figure 5.6: Average energy consumption analysis for ETRT based cross layer model.

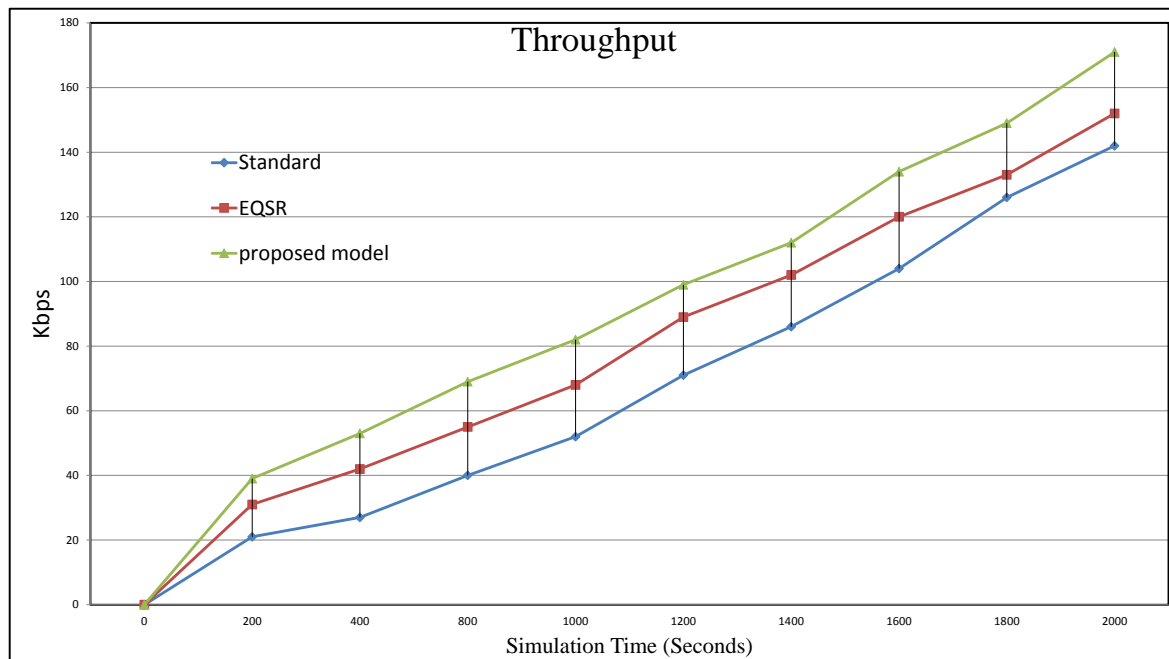

Figure 5.7: Throughput analysis for ETRT based cross layer model.

- Network Scenario 2 (NS2) - Cross layer model with only RE based routing, in

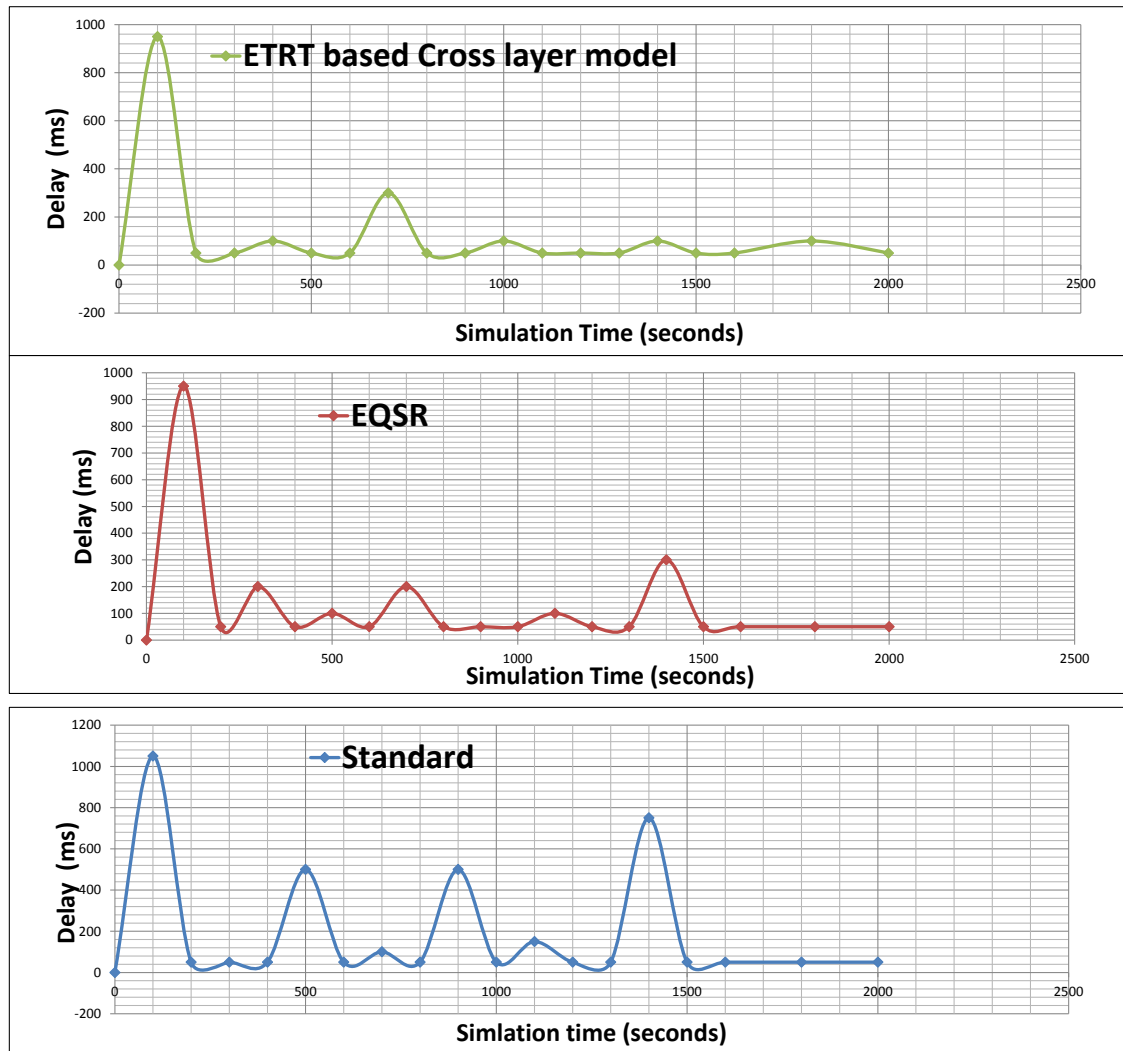

Figure 5.8: End to End Delay analysis for ETRT based cross layer model.

this scenario ETP and ETD are not calculated by routing mechanism.

- Network Scenario 3 (NS3) - Cross layer model with only ETP based routing, in this scenario RE and ETD are not calculated by routing mechanism.
- Network Scenario 4 (NS4) - Cross layer model with only ETD based routing, in this scenario RE and ETP are not calculated by routing mechanism.

From these results comparisons it is understood that effective combination of these three parameters (RE, ETP and ETD ETRT) performs much better when compared

to implementing individually (Only RE or Only ETP or Only ETD).

5.2.7.1 Average Energy Consumption

Balancing energy utilization improves the network lifetime and avoids network re-initialization. Energy efficiency of the network is estimated by the average energy consumption of the network. Balancing energy utilization is the key feature to achieve energy utilization. From Figure 5.6, it is seen that ETRT based cross layer model utilizes energy in a balanced way when compared to EQSR protocol and standard model.

5.2.7.2 Throughput

: Throughput is defined as the number of packets successfully transmitted during the network operation time. Reliability of the network is justified by the throughput of the network. Thus, in the proposed model expected throughput for every node is estimated in the routing phase and based on the routing information, the transmission range of nodes are varied, which ensures better reliability. Figure 5.7, shows the throughput estimation of ETRT based cross layer model, from the throughput comparisons it is observed that throughput of ETRT based cross layer model is higher than the standard model and EQSR protocol.

5.2.7.3 END-to-END Delay

:

Quality of Service (QoS) of the network is estimated based on the delay and latency performance of the network. Therefore, the routing metric called end-to-end delay is estimated to analyze the QoS performance of the proposed cross layer model. The End-to-end delay is measured as the sum of the delays of every successful packet sent and divided by the total number of packets transmitted.

Figure 5.8, describes the end-to-end delay performance of ETRT based cross layer model, the standard model and EQSR protocol. From the results it is observed that, in flooding process (0 to 200 seconds the control packet transmission and reception) all the three models obtain more or less same delay, since flooding process increases the delay in all network scenarios. Where as if we notice in data transmission phase (200 seconds to 2000 seconds) the delay in standard model takes 100 to 800 Milli seconds.

Where in EQSR protocol and proposed cross layer design the delay is 100 to 300 Milli seconds. From this we can say proposed cross layer model achieves energy efficiency without affecting the QoS of the network.

5.2.7.4 Highlights of ETRT based cross layer model

: In previous models (Chapter 3 and Chapter 4) the network lifetime and reliability of the network are optimized by considering the routing metrics such as,

- Node placement techniques – Data traffic
- Routing Technique – Residual Energy and Expected Transmission Time.
- ND and TL based cross layer design – Node degree and Traffic load.

All these models consider the routing metrics and optimize the energy efficiency and reliability of the network.

Where ETRT based cross layer model directly estimates the performance metrics such as,

- ETRT based cross layer model – Expected Throughput, Expected Delay and Expected Energy.

Because of directly estimating the performance metrics, we can achieve network performance better than other models. From Figures 3.9, 3.10, 3.11, Figure 4.3,4.4,4.5, Figure 5.4, 5.5, 5.6,5.7,5.8. it is seen that ETRT based cross layer model performs better than other models.

5.3 SUMMARY

- Unified network architecture that connects Internet facilitated devices is referred as Internet of Things. The Internet enabled IoT devices to work in the smarter way, but they are energy constrained in nature.
- Thus in this Chapter, an attempt has been done in introducing ETRT based cross layer model, which assures an efficient energy utilization and reliable data transfer so as to improve overall network performance. Estimating energy, reliability and QoS information in advance, can achieve reliable data transmission with better network lifetime.

- In ETRT based cross layer model, performance parameters (RE, ETP and ETD) are directly estimated before data transmission, which assures the better network performance.
- In the proposed model, routing estimates nodes capability information in prior and utilize the information by means of MAC based power control technique. Our results show that ETRT based cross layer model prolongs network lifetime with better reliability and QoS.

Chapter 6

CONCLUSION AND FUTURE DIRECTIONS

Internet of things (IoT) is the emerging technology, which allows global information sharing. The major challenges in IoT network is utilizing power in efficient way and transmitting data in reliable links. Based on these observations, an energy efficient and reliable network architecture is proposed, by effectively integrating the routing technique and node placement technique. In the node placement technique, data traffic is regulated by three different ways such as, by varying the node density, by varying the battery level of nodes and by varying the transmission range of nodes. In the routing technique energy efficient and reliable path is computed based on the residual energy and Expected Transmission Time (ETT) values. In proposed work, routing maintains reliable and energy efficient data transfer and node placement regulates the data traffic. Hence, effective integration of these two techniques improves the network lifetime and reliability efficiently. Our simulation results show that the proposed network architecture is energy efficient and reliable and it is more suitable for energy constrained IoT networks.

However, routing and node placement integrated network architecture improves network lifetime, it may increase the implementation time, since routing and node placement technique are implemented in two different phase of network. To overcome this issue, we proposed cross layer design that integrates two optimization techniques in same phase of network. In the proposed cross layer design, optimal transmission range for every node is achieved, by effectively integrating routing technique and MAC based power control technique. Energy related parameters (node degree and traffic

load) are included in routing mechanism. Later, MAC utilizes the energy related parameters, to obtain optimum transmission range for nodes in the network. Our results show that the proposed cross layer model is energy efficient and reliable and it is more suitable for low power IoT networks.

Improving energy efficiency with better reliability and QoS are the major aim in low power IoT networks. Thus, finally we proposed ETRT-based cross layer model. In our model, a term called ETRT (Expected Transmission Range Threshold) is introduced, ETRT is determined by the aid of routing information. Later, MAC based power control technique utilizes ETRT value and assigns optimum transmission range for every node in the network. The idea at the heels of ETRT-based cross layer model is estimating the capability (ETRT value) of particular node and assigning optimum transmission power for every node based on its capability (ETRT value). Hence, assigning optimum transmission power based on energy, reliability and QoS information highly improves the network performance. From the research works such as, Routing and Node placement integrated network architecture, ND and TL based Cross layer Design and ETRT based Cross layer Design. It is observed that, the proposed network architecture and proposed cross layer models highly improves the network lifetime with reliable data transfer. Hence, We conclude that the network architectures carried out in our research work are energy efficient, reliable and QoS aware and it is more suitable for low power IoT networks.

For future work, Security related optimization techniques can be integrated along with energy related optimization technique, to enhance the network performance. Integrating suitable layers that addresses energy issue as well as security issue can be the effective solution, to improve the energy efficiency with network security.

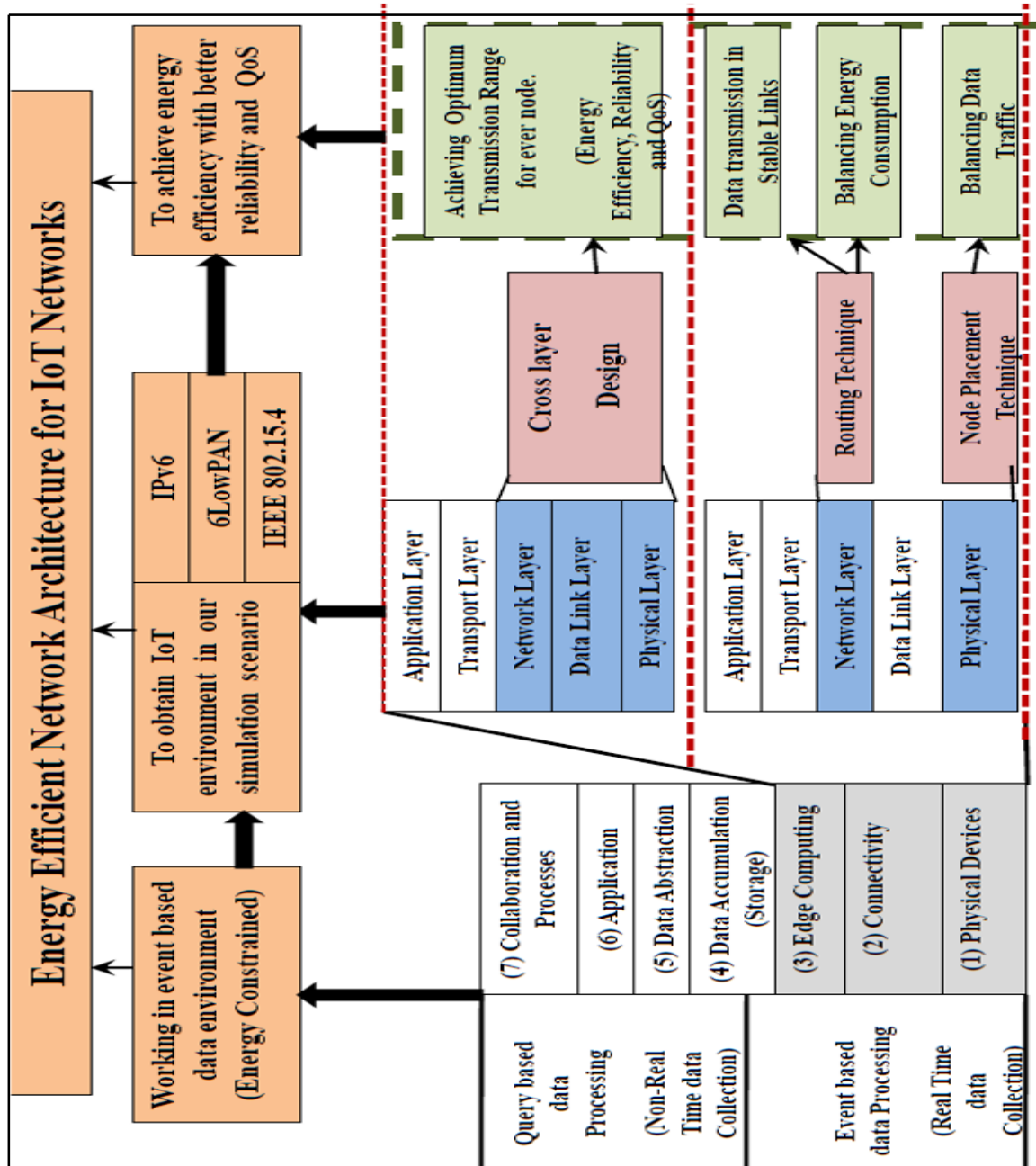

Figure 6.1: Summary of this research work

Bibliography

- A. Manjeshwar and D. P. Agarwal, (2002) “ APTEEN: A Hybrid Protocol for Efficient Routing and Comprehensive Information Retrieval in Wireless Sensor Networks.” *Parallel and Distrib. Proc. Symp.* , 195–202.
- Alabbasi, A., and Shihada, B. (2016) “Optimal cross-layer design for energy efficient d2d sharing systems.” *IEEE Transactions on Wireless Communications*, 16 (2), 839–855.
- Al-Fuqaha, A., Guizani, M., Mohammadi, M., Aledhari, M., and Ayyash M. (2015) “Internet of things: A survey on enabling technologies, protocols, and applications.” *IEEE Communications Surveys and Tutorials*, 17 (4), 2347–2376.
- Al-Jemeli, M., and Hussin, F. A. (2015) “An energy efficient cross-layer network operation model for ieee 802.15. 4-based mobile wireless sensor networks.” *IEEE Sensors Journal* , 15, 684–692.
- Al-Jemeli, M., and Hussin, F. A. (2015) “ An energy efficient cross-layer network operation model for IEEE 802.15. 4-based mobile wireless sensor networks.” *IEEE sensors journal*, 15 (2), 684–692.
- Atzori, L., Iera, A., and Morabito, (2010) “The internet of things: A survey. Computer networks. ” *Computer networks* , 54 (15), 2787–2805.
- Azzedine Boukerche (2008) “Algorithms and Protocols for Wireless Sensor Networks.” *Wiley-IEEE Press*.
- Bahuguna Renu, Mandoria Hardwari lal and Tayal Pranavi (2013) “ Routing Protocols in Mobile Ad- Hoc Network: A Review. Quality, Reliability, Security and Robustness in Heterogeneous Networks.” *Springer* , 52–60.

- Bari, A. (2005) “Relay Nodes in Wireless Sensor Networks: A Survey. ”, University of Windsor.
- Bein, D., Datta, A. K., Sajja, P., and Zheng, S.-Q. (2009) “Impact of variable transmission range in all-wireless networks.” *42nd Hawaii International Conference on System Sciences* , IEEE, 1–10.
- Ben-Othman, J., and Yahya, B. (2010) “Energy efficient and qos based routing protocol for wireless sensor networks.” *Journal of Parallel and Distributed Computing*, 70, 849–857.
- Braginsky, D., and Estrin, D. (2002) “Rumor routing algorithm for sensor networks.” *In Proceedings of the 1st ACM international workshop on Wireless sensor networks and applications*, ACM, 22–31.
- Botta, A., De Donato, W., Persico, V., and Pescap, A. () “Integration of cloud computing and internet of things: a survey. Future Generation Computer Systems. ” *Future Generation Computer Systems* , (56), 684–700.
- Boukerche, A., Cheng, X., and Linus, J. (2003) “Energy-aware data-centric routing in microsensor networks.” *6th ACM international workshop on Modeling analysis and simulation of wireless and mobile systems*, ACM , 42–49.
- Callaway, E., Gorday, P., Hester, L., Gutierrez, J. A., Naeve, M., Heile, B., and Bahl, V. (2002) “Home networking with IEEE 802.15. 4: a developing standard for low-rate wireless personal area networks.” *IEEE Communications magazine*, 40 (8), 70–77.
- Callaway, E., Gorday, P., Hester, L., Gutierrez, J. A., Naeve, M., Heile, B., and Bahl, V. (2002) “Home networking with IEEE 802.15. 4: a developing standard for low-rate wireless personal area networks.” *IEEE Communications magazine* , 40 (8), 70–77.
- Cammarano, A., Presti, F. L., Maselli, G., Pescosolido, L., (2015) “Throughput-optimal cross-layer design for cognitive radio ad hoc networks.” *IEEE Transactions on Parallel and Distributed Systems* ,26, 2599–2609.

- Chen, S., Xu, H., Liu, D., Hu, B., and Wang, H. (2014) “A vision of IoT: Applications, challenges, and opportunities with china perspective. ” *IEEE Internet of Things journal* , 1 (4), 349–359.
- Cheng, X., Du, D. Z., Wang, L., and Xu, B. (2008) “Relay sensor placement in wireless sensor networks. ” *Wireless Networks*, 14 (3), 347–355.
- Christine E. Jones, Krishna M. Sivalingam, Prathima Agrwal and Jyh Cheng Chen (2001) “ A Survey of Energy Efficient Network Protocols for Wireless Networks. Wireless Networks.” , 343–358.
- (2007) “Transmission power control techniques for wireless sensor networks.” *Computer Networks*, 51, 4765–4779.
- De, S., Qiao, C., and Wu, H. (2003) “ Meshed multipath routing with selective forwarding: an efficient strategy in wireless sensor networks.” *Computer Networks* , 43 (4), 481–497.
- (2005) “A high-throughput path metric for multi-hop wireless routing.” *Wireless networks*,, 11 (4), 419–434.
- Deering, S. E. (1998) “Internet protocol, version 6 (IPv6) specification.”
- Dimic, G., Sidiropoulos, N. D., and Zhang, R. (2004) “Medium access control-physical cross-layer design. ” *IEEE Signal Processing Magazine*, 21 (5), 40–50.
- ElBatt, T., and Ephremides, A. (2004) “Joint scheduling and power control for wireless ad hoc networks.” *IEEE Transactions on Wireless communications* , 3, 74–85.
- ElBatt, T. and Ephremides, A. (2004) “Joint scheduling and power control for wireless ad hoc networks.” *IEEE Transactions on Wireless communications* , 3, 74–85.
- Errol L. Lloyd and Guoliang Xue (2007) “Relay Node Placement in Wireless Sensor Networks” *IEEE Transactions on computer* , 56 (1), 134–138.
- Efrat, A., Har-Peled, S., and Mitchell, J. S. (2005) “Approximation algorithms for two optimal location problems in sensor networks.” *2nd International Conference on Broadband Networks* , IEEE, 714–723.

- Farooq, H., and Tang Jung, L. (2013) “Energy, traffic load, and link quality aware ad hoc routing protocol for wireless sensor network based smart metering infrastructure.” *International Journal of Distributed Sensor Networks* .
- Felemban, E., Vural, S., Murawski, R., Ekici, E., Lee, K., Moon, Y., and Park, S. (2010) “SAMAC: A cross-layer communication protocol for sensor networks with sectored antennas.” *IEEE Transactions on Mobile Computing*, 9, 1072–1088.
- Felemban, E., Vural, S., Murawski, R., Ekici, E., Lee, K., Moon, Y., and Park, S. (2010) “SAMAC: A cross-layer communication protocol for sensor networks with sectored antennas.” *IEEE Transactions on Mobile Computing* ,9, 1072–1088.
- Ganesan, D., Govindan, R., Shenker, S., and Estrin, D., (2001) “Highly-resilient, energy-efficient multipath routing in wireless sensor networks.” *ACM SIGMOBILE Mobile Computing and Communications Review* , 5 (4), 11–25.
- Gou, H., Yoo, Y., and Zeng, H. (2009) “A partition-based LEACH algorithm for wireless sensor networks. ” *Ninth IEEE International Conference on Computer and Information Technology* , IEEE, 40–45.
- Gubbi, J., Buyya, R., Marusic, S., and Palaniswami, M. (2013) “Internet of Things (IoT): A vision, architectural elements, and future directions. ” *Future generation computer systems* , 29 (7), 1645–1660.
- Gun, M., Kosar, R., and Ersoy, C. (2007) “Lifetime optimization using variable battery capacities and nonuniform density deployment in wireless sensor networks. ” *In Computer and information sciences*, IEEE, 1–6.
- (2012) “Node degree based clustering for wsn.” *International Journal of Computer Applications* , 40, 49–55.
- He, S., Chen, J., Yau, D. K., and Sun, Y. (2012) “Cross-layer optimization of correlated data gathering in wireless sensor networks.” *IEEE Transactions on Mobile Computing* , 11, 1678–1691.
- He, S., Chen, J., Yau, D. K., and Sun, Y. (2012) “Cross-layer optimization of correlated data gathering in wireless sensor networks.” *IEEE Transactions on Mobile Computing*, 11, 1678–1691.

- He, T., Stankovic, J. A., Lu, C., and Abdelzaher, (2004) “SPEED: A stateless protocol for real-time communication in sensor networks. In *Distributed Computing Systems ” Proceedings of 23rd International Conference on In Distributed Computing Systems* , 46–55.
- Heinzelman, W. R., Chandrakasan, A., and Balakrishnan, H. (2000) “Energy-efficient communication protocol for wireless microsensor networks. ” *Proceedings of the 33rd annual Hawaii international conference on System sciences*, IEEE, 10–pp.
- I. T. U. and Unit (2005) “ The Internet of things.” *International Telecommunication Union (ITU) Report*.
- Intanagonwiwat, Chalermek, Ramesh Govindan, and Deborah Estrin. (2000) “Directed diffusion: A scalable and robust communication paradigm for sensor networks. ” *6th annual international conference on Mobile computing and networking. ACM* , , 56–67.
- J. L. Gao (2010) “Energy efficient routing for wireless sensor networks.” *Electrical and Computer Engineering Department, UCLA* , Thesis.
- J. N. Al-Karaki and A. E. Kamal (2004) “Routing techniques in sensor networks: A survey.” *IEEE Communications*, 11 (6), 6–23.
- Javaid, N. (2010) “Analysis and design of quality link metrics for routing protocols in Wireless Networks” *Doctoral dissertation, Universit Paris-Est*.
- Jie Jia, Guiyuan Zhang, XueliWu, Jian Chen, XingweiWang, Xiaolei Yan, (2013) “On the Problem of Energy Balanced Relay Sensor Placement in Wireless Sensor Networks” *Hindawi Publishing Corporation* , Article ID 342904.
- Ju, H., Liang, B., Li, J., Long, Y., and Yang, X. (2015) “Adaptive cross-network cross-layer design in heterogeneous wireless networks.” *IEEE Transactions on Wireless Communications*,14, 655–669.
- Jung, E.-S., and Vaidya, N. H. (2002) “A power control mac protocol for ad hoc networks.” *In Proceedings of the 8th annual international conference on Mobile computing and networking*, ACM, 36–47.

- Kang, T., Yun, J., Lee, H., Lee, I., Kim, H., Lee, B., ... and Han, K. (2007) "A clustering method for energy efficient routing in wireless sensor networks." *In Proceedings of the 6th WSEAS International Conference on Electronics*, , 133–138.
- Karlof, C., Li, Y. P., and Polastre, J. (2003) "ARRIVE: Algorithm for robust routing in volatile environments." *Computer Science Division*, University of California .
- Kim, B. C., Lee, H. S., and Ma, J. S. (2005) "Enhanced ad hoc on-demand distance vector (EAODV) routing protocol with route distribution." *IEEE 62nd Vehicular Technology Conference*, , 314–318.
- Koustuv Dasgupta, Meghna Kukreja, Konstantinos Kalpakis, (2003) "Topology Aware Placement and Role Assignment for Energy-Efficient Information Gathering in Sensor Networks" *Proceedings of the Eighth IEEE International Symposium on Computers and Communication* , 341–348.
- Larzon, L.-A., Bodin, U., and Schellen, O. (2002) "Hints and notifications for wireless links. In Wireless Communications and Networking Conference" *In Wireless Communications and Networking Conference* , IEEE, 635–641.
- Larzon, L. A., Bodin, U., and Scheln, O.(2002) "Hints and notifications" *International Conference on Wireless Communications and Networking Conference* , IEEE, 635–641.
- (2002) " PEGASIS: Power-efficient gathering in sensor information systems." *In Aerospace conference proceedings* , 3–13.
- Lee, G. M., Park, J., Kong, N., and Crespi, N. (2011) "The Internet of Things Concept and Problem Statement." *Internet Research Task Force. IETF Report*.
- Lee, G. J., Kong, J. U., Lee, M. S., and Byeon, O. H. (2005) " A cluster-based energy-efficient routing protocol without location information for sensor networks." *Journal of Information Processing Systems* , 1 (1), 49–54.
- Lee, S. J., and Gerla, M. (2000) "AODV-BR: Backup routing in ad hoc networks." *In Wireless Communications and Networking Conference*, 1311–1316.
- Li, J., Andrew, L. L., Foh, C. H., Zukerman, M., and Chen, H. H. (2009) "Connectivity, coverage and placement in wireless sensor networks." *Sensors*, 9 (10), 7664–7693.

- Liu, J., Wan, J., Wang, Q., Zeng, B., and Fang, S. (2016) “ A time-recordable cross-layer communication protocol for the positioning of vehicular cyber-physical systems.” *Future Generation Computer Systems*, 56, 438–448.
- Liu, Q., Zhou, S., and Giannakis, G. B. (2004) “Cross-layer combining of adaptive modulation and coding with truncated ARQ over wireless links.” *IEEE Transactions on wireless communications*, 3 (5), 1746–1755.
- Lotf, J. J., Bonab, M. N., and Khorsandi, S. (2008) “A novel cluster-based routing protocol with extending lifetime for wireless sensor networks.” *5th IFIP International Conference on Wireless and Optical Communications Networks* , IEEE, 1–5.
- Lu, F., Du, H., Jain, A., Voelker, G. M., Snoeren, A. C., and Terzis, A. (2015) “CQIC: Revisiting cross-layer congestion control for cellular networks.” *In Proceedings of the 16th International Workshop on Mobile Computing Systems and Applications*, ACM, 45–50.
- Madan, R., Cui, S., Lall, S., and Goldsmith, N. A. (2006) “Cross-layer design for lifetime maximization in interference-limited wireless sensor networks.” *IEEE Transactions on Wireless Communications* , 5 (11).
- Mallapur, S. V., and Terdal, S. (2010) “Enhanced ad-hoc on demand multipath distance vector routing protocol. ” *preprint arXiv*, :1004–1706.
- Manjeshwar, A., and Agrawal, D. P. (2001) “TEEN: a routing protocol for enhanced efficiency in wireless sensor networks.” In null (p. 30189a).
- Mardani, M., Kim, S.-J., and Giannakis, G. B. (2012) “Cross-layer design of wireless multihop random access networks.” *IEEE Transactions on signal processing* ,60, 2562–2574.
- Marandin, D., and RAO, V. P. (2009) “Simulation of iee 802.15. 4/zigbee with network simulator-2 (ns-2)” *Retrieved October*.
- Madan, R., Cui, S., Lall, S., and Goldsmith, N. A. (2006) “ Cross-layer design for lifetime maximization in interference-limited wireless sensor networks.” *EEE Transactions on Wireless Communications*, 5 (11).

- Mhatre, V. P., Lundgren, H., and Diot, C. (2007) “Mac-aware routing in wireless mesh networks.” *Fourth Annual Conference on Wireless on Demand Network Systems and Services*, IEEE, 46–49.
- (2006) “Ad hoc on-demand multipath distance vector routing.” *Wireless communications and mobile computing* , 6 (7), 969–988.
- Mann, R. P., Namuduri, K. R., and Pendse, (2005) “Energy-aware routing protocol for ad hoc wireless sensor networks.” *Eurasip journal on wireless communications and networking*, 5, 501875.
- Mena, J., and Kalogeraki, V.(2008) “Dynamic relay node placement in wireless sensor networks.” *International Symposium on Applications and the Internet*, IEEE, 8–17.
- Muharrem Gun, Rabun Kosar, Cem Ersoy, (2007) “Lifetime Optimization Using Variable Battery Capacities and Nonuniform Density Deployment in Wireless Sensor Networks” *22nd international symposium on Computer and information sciences*, 1–6.
- Nguyen, L. T., Defago, X., Beuran, R., and Shinoda, Y. (2008) “An energy efficient routing scheme for mobile wireless sensor networks.” *IEEE International Symposium on Wireless Communication* , 568–572.
- Pan, J., Cai, L., Hou, Y. T., Shi, Y., and Shen, S. X. (2005) “Optimal base-station locations in two-tiered wireless sensor networks.” *IEEE Transactions on Mobile Computing*, 4 (5), 458–473.
- Park, P., Fischione, C., Bonivento, A., Johansson, K. H., and Sangiovanni- Vincent, A. (2011) “Breath: an adaptive protocol for industrial control applications using wireless sensor networks.” *IEEE Transactions on Mobile Computing* , 10, 821–838.
- (2011) “Breath: An adaptive protocol for industrial control applications using wireless sensor networks.” *IEEE Transactions on Mobile Computing* , 10 , 821–838.
- Perkins, C., Belding-Royer, E., and Das, S. (2003) “Ad hoc on-demand distance vector (AODV) routing ” *IETF* , RFC3561.
- Penrose, M. (2003) “ Random geometric graphs” *Oxford University Press*.

- Rajendran, V., Obraczka, K., Garcia-Luna-Aceves, J. J. (2003) “Energy-efficient, collision free medium access control for wireless sensor networks. ” *ACM SenSys 03*, 63–78.
- Rao, A., Ratnasamy, S., Papadimitriou, C., Shenker, S., and Stoica I,(2003) “ Geographic routing without location information” *Proceedings of the 9th annual international conference on Mobile computing and networking* , 96–108.
- (2007) “ Performance enhancement in AODV with accessibility prediction.” *IEEE International Mobile Adhoc and Sensor Systems* , 1–6.
- Sheng, Z., Yang, S., Yu, Y., Vasilakos, A., Mccann, J., and Leung, K. (2013) “A survey on the IETF protocol suite for the internet of things: Standards, challenges, and opportunities. ” *IETF*, 20 (6), 91–98.
- Sheng, Z., Mahapatra, C., Zhu, C., and Leung, V. C. (2015) “Recent Advances in Industrial Wireless Sensor Networks Toward Efficient Management in IoT.” *IEEE Access* , 3 , 622–637.
- Shi, L., and Fapojuwo, A. O. (2010) “TDMA scheduling with optimized energy efficiency and minimum delay in clustered wireless sensor networks.” *IEEE Transactions on Mobile Computing*, 9, 927–940.
- Singh, D., Tripathi, G., and Jara, A. J. (2014) “Future vision, architecture, challenges and services. In Internet of things (WF-IoT). ” *IEEE world forum*, IEEE, 287–292.
- Sohrabi, K., Gao, J., Ailawadhi, V., and Pottie, G. J. (2000) “ Protocols for self-organization of a wireless sensor network.” *IEEE personal communications*, 7 (5), 16–27.
- Papavassiliou, S., and Baras, J. S. (2016) “Performance-aware cross- layer design in wireless multihop networks via a weighted backpressure approach.” *IEEE/ACM Transactions on Networking* , 24, 245–258.
- (1998) “Core-stateless fair queueing: Achieving approximately fair bandwidth allocations in high speed networks” *ACM* , 28 (4), 118–130.
- Srivastava, V., and Motani, M. (2005) “ Cross-layer design: a survey and the road ahead.” *IEEE Communications Magazine* , 43 , 112–119.

- () “Cross-layer design: a survey and the road ahead.” *IEEE Communications Magazine* , 43 (12), 112–119.
- Subburam, S., and Khader, P. S. A. (2012) “Efficient two hop local route repair mechanism using Qos-aware routing for mobile Ad Hoc networks. ” *Indian Journal of Science and Technology*, 5 (11), 3651–3659.
- (2005) “ Geographic routing with limited information in sensor networks.” *Fourth International Symposium on Information processing in sensor networks*, IEEE, 269–276.
- (2002) “A stream enabled routing (SER) protocol for sensor networks.” *Medhoc-Net*, 1996–2001.
- Tauchi, M., Ideguchi, T., and Okuda, T. (2005) “ Ad-hoc routing protocol avoiding route breaks based on AODV.” *38th Annual Hawaii International Conference on System Sciences* , 322–324.
- Tong, L., Naware, V., and Venkitasubramaniam, P. (2004) “Signal processing in random access.” *IEEE Signal Processing Magazine*, 21 (5), 29–39.
- Vasseur, J. P., and Dunkels, A. (2010) “Interconnecting smart objects with ip: The next Internet.” *Morgan Kaufmann Publications*.
- Vuran, M. C., and Akyildiz, I. F. (2010) “XLP: A cross-layer protocol for efficient communication in wireless sensor networks” *IEEE transactions on mobile computing*, 9, 1578–1591.
- Vuran, M. C., and Akyildiz, I. F. (2010) “XLP: A cross-layer protocol for efficient communication in wireless sensor networks.” *IEEE transactions on mobile computing*, 9, 1578–1591.
- Wang, J., Li, D., Xing, G., and Du, H. (2010) “Cross-layer sleep scheduling design in service-oriented wireless sensor networks.” *IEEE Transactions on Mobile Computing*, 9, 1622–1633.
- Wang, J., Li, D., Xing, G., and Du, H. (2010) “Cross-layer sleep scheduling design in service-oriented wireless sensor networks.” *IEEE Transactions on Mobile Computing* , 9 , 1622–1633.

- Wang, X., Xing, G., Zhang, Y., Lu, C., Pless, R., and Gill, C. (2003) “Integrated coverage and connectivity configuration in wireless sensor networks.” *In Proceedings of the 1st international conference on Embedded networked sensor systems* , ACM, 28–39.
- Xiao, Z., He, C., AND Jiang, L. (2010) “ Slot-based model for ieee 802.15. 4 mac with sleep mechanism.” *IEEE Communications Letters* ,14.
- (2008) “ Avoiding Energy Holes in Wireless Sensor Networks with Nonuniform Node Distribution.” *IEEE Transactions on parallel and distribute systems* , 19 (5), 710–720.
- Xu, K., Hassanein, H., Takahara, G., and Wang, Q. (2010) “Relay node deployment strategies in heterogeneous wireless sensor networks.” *IEEE Transactions on Mobile Computing* , 9 (2), 145–159.
- Xylomenos, G., and Polyzos, G. C. (2001) “Quality of service support over multi-service wireless Internet links.” *Computer Networks*, 37 (5), 601–615.
- Yassein, M. B., Khamayseh, Y., and Mardini, W. (2009) “ Improvement on LEACH protocol of wireless sensor network (VLEACH)” *Journal of Digital Content Technology Application*.
- Ye, M., Li, C., Chen, G., and Wu, J. (2005) “EECS: an energy efficient clustering scheme in wireless sensor networks.” *24th IEEE International Conference on Performance, Computing, and Communications* , IEEE, 535–540.
- Ye, F., Chen, A., Lu, S., and Zhang, L. (2001) “A scalable solution to minimum cost forwarding in large sensor networks.” *Tenth International Conference on Computer Communications and Networks*, 304–309.
- Ye, F., Zhong, G., Lu, S., and Zhang, L.(2005) “Gradient broadcast: A robust data delivery protocol for large scale sensor networks. ” *Wireless Networks* , 11 (3), 285–298.
- YoungSang Yun and Ye Xia, (2013) “A Method for Deciding Node Densities in Non-Uniform Deployment of Wireless Sensors” *11th International Symposium and Workshops on Modeling and Optimization in Mobile, Ad Hoc and Wireless Networks* , 13 (17), 264–271.

- Younis, O., and Fahmy, S. (2004) “HEED: a hybrid, energy-efficient, distributed clustering approach for ad hoc sensor networks.” *IEEE Transactions on mobile computing*, 3 (4), 366–379.
- Yu, M., Leung, K. K., and Malvankar, A. (2007) “A dynamic clustering and energy efficient routing technique for sensor networks. ” *IEEE Transactions on wireless communications* , 6 (8).
- Yu, Y., Govindan, R., and Estrin, D. (2001) “Geographical and energy aware routing: A recursive data dissemination protocol for wireless sensor networks.”
- Yu, Y., Song, C., Liu, M., and Gong, H. (2011) “Energy-efficient algorithm for sensor networks with non-uniform maximum transmission range.” *Sensors* , 11, 6203–6213.
- Zhao, E., Zhang, W., Zhang, Q., and Liu, W. (2008) “Energy-balanced variable transmission range adjustment in wsns with quality coverage.” *4th International Conference on Wireless Communications, Networking and Mobile Computing*, IEEE, 1–4.
- CISCO. (2014) “IoT -World Forum Reference Model.” <https://www.cisco.com/c/dam/global> .

Publications

Book Chapters Published and Accepted

- Sarwesh P., N. Shekar V. Shet and K. Chandrasekaran, "Energy-Efficient Network Architecture for IoT Applications," Beyond the Internet of Things, Signals and Communication, Springer, ISBN 978-3-319-50758-3, 2017, pp. 119-144. **Scopus Indexed**
- Sarwesh P., N. Shekar V. Shet and K. Chandrasekaran, "Energy Efficient Network Design for IoT Healthcare Applications," Internet of Things and Big Data Technologies for Next Generation Healthcare, Studies in Big Data, Volume 23, Springer, ISBN 978-3-319-49736-5, 2017, PP. 35-61. **Scopus Indexed**
- Sarwesh P., N. Shekar V. Shet and K. Chandrasekaran, "Reliable Cross Layer Design for E-health Applications - IoT Perspective." Cognitive Data Science Methods and Models over Internet of Things (IoT), ISBN -978-3-319-70688-7 2017, pp. 97-113 **Scopus Indexed.**
- Sarwesh P., N. Shekar V. Shet and K. Chandrasekaran, "Envisioned Network Architecture for IoT Applications." EAI/Springer Innovations in communication and computing, 2017, In Press, **Scopus Indexed.**

Journals Published and Accepted

- Sarwesh P., N. Shekar V. Shet and K. Chandrasekaran, "ETRT based Cross Layer Model for Improving Lifetime of Low Power Wireless Networks- An Internet of Things Perspective," Physical Communication, Elsevier, Volume 29, August 2018, pp. 307-318. **SCI Indexed**
- Sarwesh P., N. Shekar V. Shet and K. Chandrasekaran, "Effective Integration of Reliable Routing Mechanism and Energy Efficient Node Placement Technique for Low Power IoT Networks" Journal of Grid and High Performance Computing, Volume 9, Issue 4, Article 2, 250117-012241. **Scopus Indexed.**

- Sarwesh P., N. Shekar V. Shet and K. Chandrasekaran, "Traffic Balancing Network Architecture for Enhancing Lifetime of Smart Devices in Low Power IoT Networks." Research Journal of Applied Science and Engineering, Volume 14, Issue 12, 2017. **Scopus Indexed**.
- Sarwesh P., N. Shekar V. Shet and K. Chandrasekaran, "Internet of Things: A Birds Eye View, CSI Communications, ISSN 0970-647X, Volume No. 38, Issue No.1, April 2014.

Journals Communicated

- Sarwesh P., N. Shekar V. Shet and K. Chandrasekaran, "Energy Efficient Network Architecture for Enhancing Lifetime of Smart Devices in IoT Networks." Sustainable Computing, Elsevier, (Under Review), **SCI Indexed**
- Sarwesh P., N. Shekar V. Shet and K. Chandrasekaran, "Energy Efficient Cross Layer Model to Prolong Lifetime of Low Power IoT Networks." Sustainable Computing, Elsevier, (Under Review). **SCI Indexed**
- Sarwesh P., N. Shekar V. Shet and K. Chandrasekaran, "Energy Efficient Network Architecture for Maximizing Lifetime of IoT Networks in e-health Applications," Arabian Journal of Science and Engineering, Springer, (Under Review). **SCI Indexed**

Conference papers Published and Accepted

- P., N. Shekar V. Shet and K. Chandrasekaran, "Energy efficient network architecture for IoT applications, IEEE International Conference on Green Computing and Internet of Things(ICGCIoT), 2015, IEEE, pp. 784 - 789.
- Sarwesh P., N. Shekar V. Shet and K. Chandrasekaran, "Energy Efficient and Reliable Network Design to Improve Lifetime of Low Power IoT Networks" IEEE International Conference on Wireless Communications, Signal Processing and Networking, 2017, IEEE, pp. 117-122.
- Sonia Prasad, Shubham Jaiswal, Neelavar Shet and Sarwesh P, "Aware Routing Protocol for Resource Constrained Wireless Sensor Networks." ACM International Conference on Informatics And Analytics, 2016, pp. 1-7.

Bio-data

Name : SARWESH P

Address : 13, A PERIANNAN PILLAI STREET, POTHANUR POST,
NAMAKKAL DISTRICT, TAMILNADU, PIN-638181.

Email : sarweshperiyasamy@gmail.com

Educational Qualification

- Bachelor of Engineering - Electronics and Communicaiton Engineering (76 %)
- Master of Engineering - Communication Systems (85 %)